



CHINA SPECIAL FASTENERS, INC.

GOEBEL Fasteners Inc.
innovative fastener solutions



BLIND RIVET CATALOG

"Quality The First Time"



TRADE NAME CROSS REFERENCE TABLE



STANDARD BLIND RIVETS								TYPICAL CROSS OF PLACED FASTENER
GOEBEL	POP	AVDEL	GESIPA	HUCK	RIVET KING	MARSON	ORNIT	
STANDARD	OPEN END	OPEN END	OPEN END		OPEN END	OPEN END		
CUP	CLOSED END	CLOSED END	CAP®		CLOSED END	CAP		
MULTI-GRIP BLIND RIVETS								
MULTI-CT MULTI-RT	MULTIGRIP™	AVEX®	POLYGRIP		MULTI-GRIP-CT MULTI-GRIP-RT	MULTI-GRIP™	U-FIX	
SEMI-STRUCTURAL BLIND RIVETS								
GO-BULB	HR-RIVET®	AVIBULB®	G-BULB®		RIVIBULB®		STELOCK	
GO-INOX		AVINOX®			RIVINOX®			
STRUCTURAL BLIND RIVETS								
M-LOCK		MONOBOLT®			TIGERBOLT®		OR-BOLT	
GO-LOCK		INTERLOCK®	MEGAGRIP®	MAGNALOK®	IN-LOCK®	KLICK-LOCK	ORNILOCK	
H-LOCK		HEMLOK®		AUTOBOLT®	STEMLOCK™			
PREMIUM							ORLOCK	
TRI-FOLDING / LOAD SPREADING RIVETS								
TRI-GO	LSR LOAD "R" SPREADING	BULBEX®	TRI-FOLD®		TRI-FIX™	TRI-BULB®	OR-BULB	
TRE-GO		KLAMPTITE®	BULB-TITE®	MAGNATITE®	SUPERTRIFIX™			
SPECIALTY BLIND RIVETS								
RILLI					GROOVED RIVETS			
STAR		T RIVET	PEEL BLIND RIVET		PLR RIVETS™			

MULTIGRIP™, HR-RIVET®, LSR LOAD SPREADING® ARE REGISTERED TRADEMARKS OF POP®
 AVEX®, AVIBULB®, AVINIX®, MONOBOLT®, INTERLOCK®, HEMLOK®, BULBEX®, KLAPTITE® ARE REGISTERED TRADEMARKS OF AVDEL®
 CAP®, POLYGRIP®, G-BULB®, MEGAGRIP®, TRI-FOLD®, BULB-TITE® ARE REGISTERED TRADEMARKS OF GESIPA®
 MAGNALOK®, AUTOBOLT®, MAGNATITE® ARE REGISTERED TRADEMARKS OF HUCK®
 MULTI-GRIP-CT™, MULTI-GRIP-RT™, RIVIBULB®, RIVINOX®, TIGERBOLT®, IN-LOCK®, STEMLOCK®, TRI-FIX®, SUPERTRIFIX®, PLR RIVETS® ARE REGISTERED TRADEMARKS OF RIVET KING
 MULTI-GRIP™, KLICK-LOCK®, TRI-BULB® ARE REGISTERED TRADEMARKS OF MARSON

Subject to modifications



RIVET SELECTION GUIDE

INDUSTRIAL RIVET PART NUMBERS ARE MADE UP OF SIX ELEMENTS WHICH, WHEN CORRECTLY DESIGNATED, COMPLETELY DESCRIBE THE DESIRED RIVET. FOR LARGE FLANGE RIVETS A 7TH ELEMENT (THE SUFFIX LETTER F) IS REQUIRED.

A	B	A	4	2	LF	CE
RIVET BODY MATERIAL	HEAD STYLE	MANDREL MATERIAL	DIAMETER* (in 32nds)	GRIP RANGE* (in 16ths)	SPECIAL FEATURE	RIVET TYPE
A ALUMINUM	B DOME HEAD C COUNTERSUNK HEAD	A ALUMINUM	4 - 1/8" 5 - 5/32" 6 - 3/16" 8 - 1/4"		LF LARGE FLANGE	<i>BLANK</i> OPEN END
S STEEL		S STEEL				CE CLOSED END
I STAINLESS STEEL (AISI 304)		I STAINLESS STEEL (AISI 304)				MGCT MULTI-GRIP CRIMP TYPE
J STAINLESS STEEL (AISI 316)		J STAINLESS STEEL (AISI 316)				MGRT MULTI-GRIP RING TYPE
D DUPLEX (AISI 318 LN)		D DUPLEX (AISI 318 LN)				GB GO-BULB II
M STAINLESS STEEL (AISI 420)		M STAINLESS STEEL (AISI 420)				GI GO-INOX II
						ML M-LOCK
						GL GO-LOCK
						HL H-LOCK
						PM PREMIUM
						TIG TRI-GO
						TEG TRE-GO
						GR "RILLI" GROOVED RIVET
						PR "STAR" PEEL RIVET

* In some instances these are replaced with a "part code" instead a fractional designation.

IF YOU ARE SEARCHING FOR A SPECIFIC QUALITY, A MATERIAL COMBINATION OR A MEASUREMENT WHICH IS NOT LISTED IN THE CATALOG, PLEASE DON'T HESITATE TO CONTACT US.

ALTERNATIVELY WE CAN DEVELOP A CUSTOM BLIND RIVET TYPE ESPECIALLY FOR YOUR APPLICATION.
FOR EXAMPLE:

- SOFTER BREAKING POINT **1**
- DISPLACED BREAKING POINT **2**
- GROOVED MANDREL **3**
- LONGER MANDREL **4**
ETC.

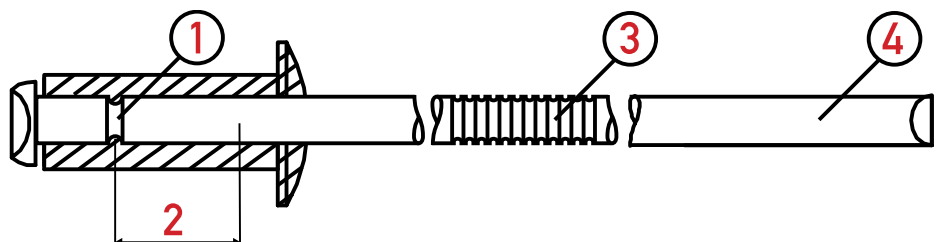



BLIND RIVETS

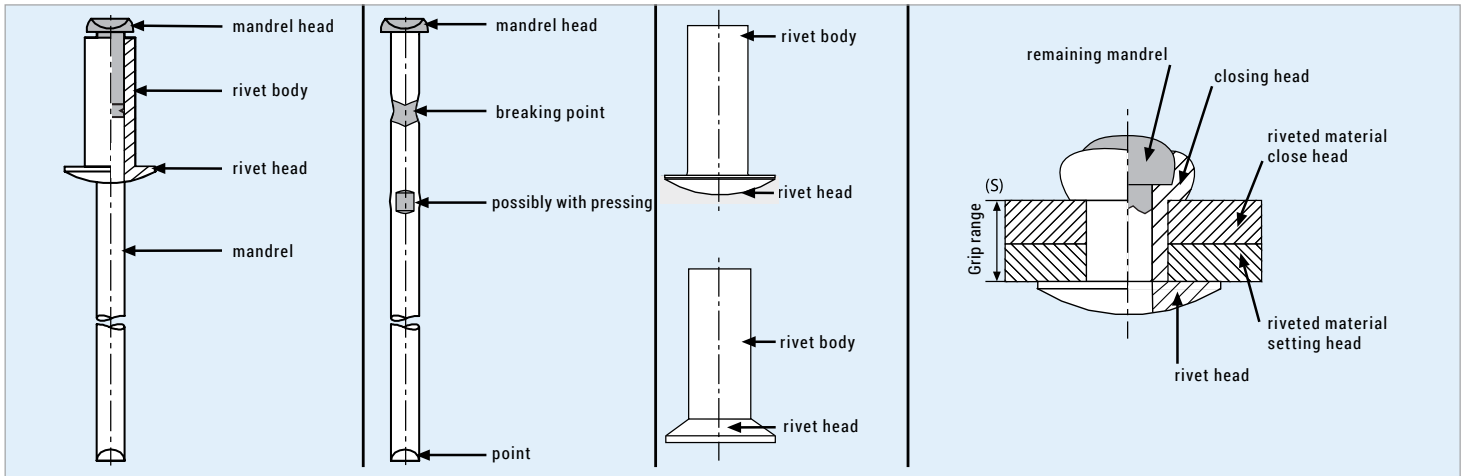

	<p>THE MATERIAL THICKNESS MUST BE WITHIN THE MINIMUM AND THE MAXIMUM VALUE FOR WHICH THE PARTICULAR BLIND RIVET IS DESIGNED.</p>
	<p>THE NAMED SHEARING STRENGTH (KN = KILO NEWTON) IN THIS CATALOG IS THE FORCE OF THE MECHANICAL BREAKDOWN OF THE RIVET.</p>
	<p>THE NAMED TENSILE STRENGTH (KN = KILO NEWTON) IN THIS CATALOG IS THE FORCE OF THE MECHANICAL BREAKDOWN OF THE RIVET.</p>

STRENGTH CHARACTERISTICS

GO-BULB, GO-INOX, M-LOCK, GO-LOCK, H-LOCK, PREMIUM, TRE-GO fasteners all offer high shear and tensile strength. Please refer to the technical data sheets for typical strength values.

CORROSION RESISTANT

The connecting parts in a specific application must have at least the same corrosion resistance as the connected components. If this is not possible, the connecting parts must be of higher quality than the components. Stainless steel fasteners offer the best corrosion resistance.

LIMITED WARRANTY

Goebel Fasteners, Inc. ("Seller"). Seller warrants that products sold hereunder conform to industry standards specified herein and will be free from defects in materials and workmanship. THIS WARRANTY IS EXPRESSLY GIVEN IN LIEU OF ANY AND ALL OTHER EXPRESS OR IMPLIED WARRANTIES, INCLUDING ANY IMPLIED WARRANTY OF MERCHANTABILITY OR FITNESS FOR A PARTICULAR PURPOSE, AND IN LIEU OF ANY OTHER OBLIGATION ON THE PART OR THE SELLER. Seller will, at its option, repair or replace free of charge (excluding all shipping and handling costs) any products which have not been subject to misuse, abuse or modification and which in its sole determination were not manufactured in compliance with the warranty given above.

It is expressly understood that any technical advice furnished by or on behalf of Seller with respect to the use of its goods or services is given without charge, and Seller assumes no obligations or liability for the advice given or results obtained. All such results being given and accepted is at Buyer's Risk.

THE REMEDY PROVIDED FOR HEREIN SHALL BE THE EXCLUSIVE REMEDY FOR ANY BREACH OF WARRANTY OR ANY CLAIM ARISING IN ANY WAY OUT OF THE MANUFACTURE, SALE, OR USE OF THESE PRODUCTS. In no event shall Seller be liable for consequential, incidental or any other damages of any nature whatsoever except those specifically provided herein for any breach of warranty or any claim arising in any way out of the manufacture, sale, or use of these products. No other person is authorized by Seller to give any other warranty, written or oral, pertaining to the products.



RIVET DETERMINATION GUIDE

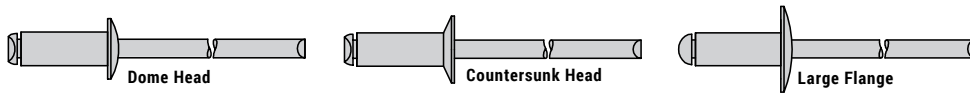

STANDARD BLIND RIVETS

Open End "STANDARD"					Closed End "CUP"				
Aluminum Aluminum	Aluminum Steel	Steel Steel	Stainless Steel (AISI 304) Stainless Steel (AISI304)	Stainless Steel (AISI316) Stainless Steel (AISI316)	Aluminum Aluminum	Aluminum Steel	Aluminum Stainless Steel (AISI 304)	Stainless Steel (AISI 304) Stainless Steel (AISI 420)	Stainless Steel (AISI 316) Stainless Steel (AISI 318LN)
ABA ACA ABA-LF	ABS ACS ABS-LF	SBS SCS SBS-LF	IBI ICI IBI-LF	JB	ABA-CE	ABS-CE ACS-CE	ABI-CE ACI-CE	IBM-CE	JBD-CE
Pg. 8, 13, 17	Pg. 9, 14, 18	Pg. 10, 15, 19	Pg. 11, 16, 20	Pg. 12	Pg. 21	Pg. 22, 26	Pg. 23, 27	Pg. 24	Pg. 25

MULTI-GRIP BLIND RIVETS

MULTI - CT		MULTI - RT		
Aluminum Steel	Aluminum Stainless Steel (AISI 304)	Steel Steel	Stainless Steel (AISI 304) Stainless Steel (AISI 304)	Stainless Steel (AISI 316) Stainless Steel (AISI 316)
ABS-MGCT ACS-MGCT ABS-LFMGCT	ABI-MGCT ABI-LFMGCT	SBS-MGRT SCS-MGRT SBS-LFMGRT	IBI-MGRT	JB
Pg. 28, 33, 35	Pg. 29, 36	Pg. 30, 34, 37	Pg. 31	Pg. 32

SEMI-STRUCTURAL BLIND RIVETS

GO-BULB	GO-INOX
Steel Steel	Stainless Steel (AISI 304) Stainless Steel (AISI 304)
SBS-GB	IBI-GI
Pg. 38	Pg. 39

STRUCTURAL BLIND RIVETS

M-LOCK		GO-LOCK			H-LOCK	PREMIUM	PREMIUM
Aluminum Aluminum	Steel Steel	Stainless Steel (AISI 304) Stainless Steel (AISI 304)	Aluminum Aluminum	Steel Steel	Stainless Steel (AISI 304) Stainless Steel (AISI 304)	Steel Steel	Stainless Steel (AISI 304) Stainless Steel (AISI 304)
ABA-ML ACA-ML	SBS-ML SCS-ML	IBI-ML ICI-ML	ABA-GL	SBS-GL SCS-GL	IBI-GL	SBS-HL	SBS-PM
Pg. 40, 43	Pg. 41, 44	Pg. 42, 45	Pg. 46	Pg. 47, 49	Pg. 48	Pg. 50	Pg. 51

TRI-FOLDING / LOAD SPREADING RIVETS

TRI-GO	TRE-GO
Aluminum Aluminum	Aluminum Aluminum
ABA-TIG	ABA-TEG
Pg. 53	Pg.54

SPECIALTY BLIND RIVETS

RILLI	STAR
Aluminum Steel	Aluminum Steel
ABS-GR	ABS-PR
Pg. 55	Pg. 56



BLIND RIVETS - STANDARD

DOME HEAD

ABA-SERIES - OPEN END

Body: **ALUMINUM**
Mandrel: **ALUMINUM**

PER IFI-114 GRADE 11

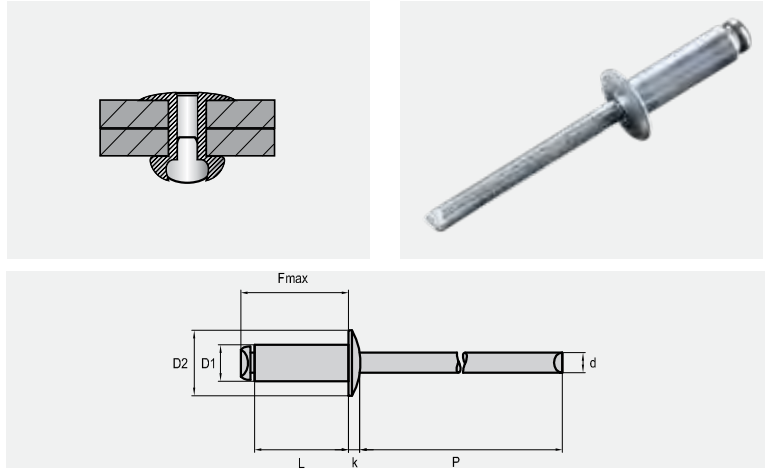

DESCRIPTION ITEM-CODE	BODY LENGTH ref.		GRIP RANGE				SHEAR		TENSILE		
	in	mm	in		mm		lbf	kn	lbf	kn	
			min	max	min	max					
1/8" (3.2 mm) D1 = 1/8" 3.2 mm D2 = .250" 6.35 mm k = .040" 1.0 mm d = .076" 1.9 mm P = ≥ 1.063" 27.0 mm .13" 3.3 mm	ABA-41	.212	5.385	.032	.062	0.813	1.575	120	0.53	150	0.67
	ABA-42	.275	6.985	.063	.125	1.600	3.175				
	ABA-43	.337	8.560	.126	.187	3.200	4.750				
	ABA-44	.400	10.160	.188	.250	4.775	6.350				
	ABA-45	.462	11.735	.251	.312	6.375	7.925				
	ABA-46	.525	13.335	.313	.375	7.950	9.525				
	ABA-48	.650	16.510	.376	.500	9.550	12.700				
	ABA-410	.775	19.685	.501	.625	12.725	15.875				
5/32" (4.0 mm) D1 = 5/32" 4.0 mm D2 = .315" 8.0 mm k = .050" 1.27 mm d = .095" 2.4 mm P = ≥ 1.063" 27.0 mm .161" 4.1 mm	ABA-52	.300	7.620	.063	.125	1.600	3.175	190	0.85	230	1.02
	ABA-53	.362	9.195	.126	.187	3.200	4.750				
	ABA-54	.425	10.795	.188	.250	4.775	6.350				
	ABA-56	.550	13.970	.251	.375	6.375	9.525				
	ABA-58	.675	17.145	.376	.500	9.550	12.700				
	3/16" (4.8 mm) D1 = 3/16" 4.8 mm D2 = .375" 9.5 mm k = .060" 1.52 mm d = .114" 2.9 mm P = ≥ 1.063" 27.0 mm .193" 4.9 mm	ABA-62	.325	8.255	.063	.125	1.600				
ABA-63		.387	9.830	.126	.187	3.200	4.750				
ABA-64		.450	11.430	.188	.250	4.775	6.350				
ABA-66		.575	14.605	.251	.375	6.375	9.525				
ABA-68		.700	17.780	.376	.500	9.550	12.700				
ABA-610		.825	20.955	.501	.625	12.725	15.875				
ABA-612		.950	24.130	.626	.750	15.900	19.050				
ABA-614		1.075	27.305	.751	.875	19.075	22.225				
ABA-616		1.200	30.480	.876	1.000	22.250	25.400				
1/4" (6.4 mm) D1 = 1/4" 6.4 mm D2 = .500" 12.7 mm k = .080" 2.0 mm d = .151" 3.84 mm P = ≥ 1.26" 32.0 mm .256" 6.5 mm		ABA-84	.500	12.700	.126	.250	3.200	6.350	460	2.05	560
	ABA-86	.625	15.875	.251	.375	6.375	9.525				
	ABA-88	.750	19.050	.376	.500	9.550	12.700				
	ABA-810	.875	22.225	.501	.625	12.725	15.875				
	ABA-812	1.000	25.400	.626	.750	15.900	19.050				
	ABA-814	1.125	28.575	.751	.875	19.075	22.225				
	ABA-816	1.250	31.750	.876	1.000	22.250	25.400				



BLIND RIVETS - STANDARD

DOME HEAD

ABS-SERIES - OPEN END

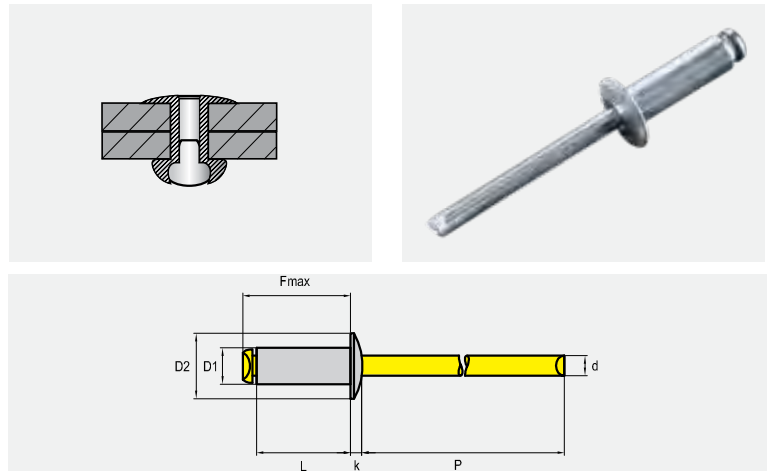

Body: **ALUMINUM**

Mandrel: **STEEL ZINC PLATED (GALV.)**

PER IFI-114 GRADE 16

DESCRIPTION ITEM-CODE	BODY LENGTH ref.		GRIP RANGE				SHEAR		TENSILE		
	in	mm	in		mm		lbf	kn	lbf	kn	
			min	max	min	max					
1/8" (3.2 mm) D1 = 1/8" 3.2 mm D2 = .250" 6.35 mm k = .040" 1.0 mm d = .076" 1.9 mm P = ≥ 1.063" 27.0 mm .13" 3.3 mm	ABS-41	.212	5.385	.032	.062	0.813	1.575	170	0.76	220	0.98
	ABS-42	.275	6.985	.063	.125	1.600	3.175				
	ABS-43	.337	8.560	.126	.187	3.200	4.750				
	ABS-44	.400	10.160	.188	.250	4.775	6.350				
	ABS-45	.462	11.735	.251	.312	6.375	7.925				
	ABS-46	.525	13.335	.313	.375	7.950	9.525				
	ABS-48	.650	16.510	.376	.500	9.550	12.700				
	ABS-410	.775	19.685	.501	.625	12.725	15.875				
5/32" (4.0 mm) D1 = 5/32" 4.0 mm D2 = .315" 8.0 mm k = .050" 1.27 mm d = .095" 2.4 mm P = ≥ 1.063" 27.0 mm .161" 4.1 mm	ABS-52	.300	7.620	.063	.125	1.600	3.175	260	1.16	350	1.56
	ABS-53	.362	9.195	.126	.187	3.200	4.750				
	ABS-54	.425	10.795	.188	.250	4.775	6.350				
	ABS-56	.550	13.970	.251	.375	6.375	9.525				
	ABS-58	.675	17.145	.376	.500	9.550	12.700				
	ABS-510	.800	20.320	.501	.625	12.725	15.875				
3/16" (4.8 mm) D1 = 3/16" 4.8 mm D2 = .375" 9.5 mm k = .060" 1.52 mm d = .114" 2.9 mm P = ≥ 1.063" 27.0 mm .193" 4.9 mm	ABS-62	.325	8.255	.063	.125	1.600	3.175	380	1.69	500	2.22
	ABS-63	.387	9.830	.126	.187	3.200	4.750				
	ABS-64	.450	11.430	.188	.250	4.775	6.350				
	ABS-66	.575	14.605	.251	.375	6.375	9.525				
	ABS-68	.700	17.780	.376	.500	9.550	12.700				
	ABS-610	.825	20.955	.501	.625	12.725	15.875				
	ABS-612	.950	24.130	.626	.750	15.900	19.050				
	ABS-614	1.075	27.305	.751	.875	19.075	22.225				
	ABS-616	1.200	30.480	.876	1.000	22.250	25.400				
1/4" (6.4 mm) D1 = 1/4" 6.4 mm D2 = .500" 12.7 mm k = .080" 2.0 mm d = .151" 3.84 mm P = ≥ 1.26" 32.0 mm .256" 6.5 mm	ABS-84	.500	12.700	.126	.250	3.200	6.350	700	3.11	920	4.09
	ABS-86	.625	15.875	.251	.375	6.375	9.525				
	ABS-88	.750	19.050	.376	.500	9.550	12.700				
	ABS-810	.875	22.225	.501	.625	12.725	15.875				
	ABS-812	1.000	25.400	.626	.750	15.900	19.050				
	ABS-814	1.125	28.575	.751	.875	19.075	22.225				
	ABS-816	1.250	31.750	.876	1.000	22.250	25.400				



BLIND RIVETS - STANDARD

DOME HEAD

SBS-SERIES - OPEN END

Body: **STEEL ZINC PLATED (GALV.)**

Mandrel: **STEEL ZINC PLATED (GALV.)**

PER IFI-114 GRADE 30

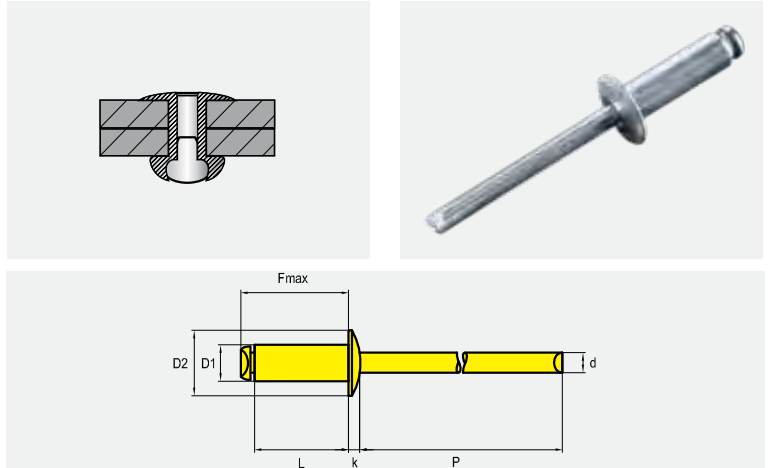

DESCRIPTION ITEM-CODE	BODY LENGTH ref.		GRIP RANGE				SHEAR		TENSILE		
	in	mm	in		mm		lbf	kn	lbf	kn	
			min	max	min	max					
1/8" (3.2 mm) D1 = 1/8" 3.2 mm D2 = .250" 6.35 mm k = .040" 1.0 mm d = .076" 1.9 mm P = ≥ 1.063" 27.0 mm .13" 3.3 mm	SBS-41	.212	5.385	.032	.062	0.813	1.575	260	1.16	310	1.38
	SBS-42	.275	6.985	.063	.125	1.600	3.175				
	SBS-43	.337	8.560	.126	.187	3.200	4.750				
	SBS-44	.400	10.160	.188	.250	4.775	6.350				
	SBS-45	.462	11.735	.251	.312	6.375	7.925				
	SBS-46	.525	13.335	.313	.375	7.950	9.525				
	SBS-48	.650	16.510	.376	.500	9.550	12.700				
	SBS-410	.775	19.685	.501	.625	12.725	15.875				
5/32" (4.0 mm) D1 = 5/32" 4.0 mm D2 = .315" 8.0 mm k = .050" 1.27 mm d = .095" 2.4 mm P = ≥ 1.063" 27.0 mm .161" 4.1 mm	SBS-52	.300	7.620	.063	.125	1.600	3.175	370	1.65	470	2.09
	SBS-53	.362	9.195	.126	.187	3.200	4.750				
	SBS-54	.425	10.795	.188	.250	4.775	6.350				
	SBS-56	.550	13.970	.251	.375	6.375	9.525				
	SBS-58	.675	17.145	.376	.500	9.550	12.700				
	SBS-510	.800	20.320	.501	.625	12.725	15.875				
3/16" (4.8 mm) D1 = 3/16" 4.8 mm D2 = .375" 9.5 mm k = .060" 1.52 mm d = .114" 2.9 mm P = ≥ 1.063" 27.0 mm .193" 4.9 mm	SBS-62	.325	8.255	.063	.125	1.600	3.175	540	2.40	680	3.02
	SBS-63	.387	9.830	.126	.187	3.200	4.750				
	SBS-64	.450	11.430	.188	.250	4.775	6.350				
	SBS-66	.575	14.605	.251	.375	6.375	9.525				
	SBS-68	.700	17.780	.376	.500	9.550	12.700				
	SBS-610	.825	20.955	.501	.625	12.725	15.875				
	SBS-612	.950	24.130	.626	.750	15.900	19.050				
	SBS-614	1.075	27.305	.751	.875	19.075	22.225				
	SBS-616	1.200	30.480	.876	1.000	22.250	25.400				
1/4" (6.4 mm) D1 = 1/4" 6.4 mm D2 = .500" 12.7 mm k = .080" 2.0 mm d = .151" 3.84 mm P = ≥ 1.26" 32.0 mm .256" 6.5 mm	SBS-84	.500	12.700	.126	.250	3.200	6.350	1000	4.45	1240	5.52
	SBS-86	.625	15.875	.251	.375	6.375	9.525				
	SBS-88	.750	19.050	.376	.500	9.550	12.700				
	SBS-810	.875	22.225	.501	.625	12.725	15.875				
	SBS-812	1.000	25.400	.626	.750	15.900	19.050				
	SBS-814	1.125	28.575	.751	.875	19.075	22.225				
	SBS-816	1.250	31.750	.876	1.000	22.250	25.400				



BLIND RIVETS - STANDARD

DOME HEAD

IBI-SERIES - OPEN END

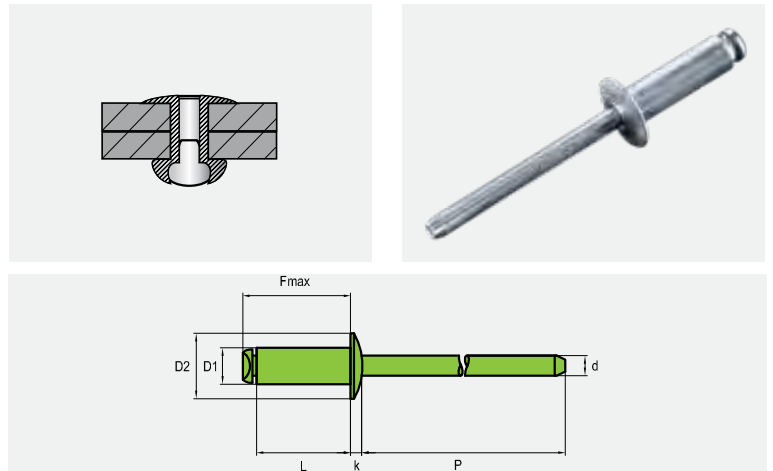

Body: **AISI 304 STAINLESS STEEL**
Mandrel: **AISI 304 STAINLESS STEEL**

PER IFI-114 GRADE 51

DESCRIPTION ITEM-CODE	BODY LENGTH ref.		GRIP RANGE				SHEAR		TENSILE		
	in	mm	in		mm		lbf	kn	lbf	kn	
			min	max	min	max					
1/8" (3.2 mm) D1 = 1/8" 3.2 mm D2 = .250" 6.35 mm k = .040" 1.0 mm d = .076" 1.9 mm P = ≥ 1.063" 27.0 mm .13" 3.3 mm	IBI-41	.212	5.385	.032	.062	0.813	1.575	420	1.87	530	2.36
	IBI-42	.275	6.985	.063	.125	1.600	3.175				
	IBI-43	.337	8.560	.126	.187	3.200	4.750				
	IBI-44	.400	10.160	.188	.250	4.775	6.350				
	IBI-45	.462	11.735	.251	.312	6.375	7.925				
	IBI-46	.525	13.335	.313	.375	7.950	9.525				
	IBI-48	.650	16.510	.376	.500	9.550	12.700				
5/32" (4.0 mm) D1 = 5/32" 4.0 mm D2 = .315" 8.0 mm k = .050" 1.27 mm d = .095" 2.4 mm P = ≥ 1.063" 27.0 mm .161" 4.1 mm	IBI-52	.300	7.620	.063	.125	1.600	3.175	650	2.89	820	3.65
	IBI-53	.362	9.195	.126	.187	3.200	4.750				
	IBI-54	.425	10.795	.188	.250	4.775	6.350				
	IBI-56	.550	13.970	.251	.375	6.375	9.525				
	IBI-58	.675	17.145	.376	.500	9.550	12.700				
3/16" (4.8 mm) D1 = 3/16" 4.8 mm D2 = .375" 9.5 mm k = .060" 1.52 mm d = .114" 2.9 mm P = ≥ 1.063" 27.0 mm .193" 4.9 mm	IBI-62	.325	8.255	.063	.125	1.600	3.175	950	4.23	1200	5.34
	IBI-63	.387	9.830	.126	.187	3.200	4.750				
	IBI-64	.450	11.430	.188	.250	4.775	6.350				
	IBI-66	.575	14.605	.251	.375	6.375	9.525				
	IBI-68	.700	17.780	.376	.500	9.550	12.700				
	IBI-610	.825	20.955	.501	.625	12.725	15.875				
	IBI-612	.950	24.130	.626	.750	15.900	19.050				
	IBI-614	1.075	27.305	.751	.875	19.075	22.225				
IBI-616	1.200	30.480	.876	1.000	22.250	25.400					
1/4" (6.4 mm) D1 = 1/4" 6.4 mm D2 = .500" 12.7 mm k = .080" 2.0 mm d = .151" 3.84 mm P = ≥ 1.26" 32.0 mm .256" 6.5 mm	IBI-84	.500	12.700	.126	.250	3.200	6.350	1700	7.56	2100	9.34
	IBI-86	.625	15.875	.251	.375	6.375	9.525				
	IBI-88	.750	19.050	.376	.500	9.550	12.700				
	IBI-810	.875	22.225	.501	.625	12.725	15.875				
	IBI-812	1.000	25.400	.626	.750	15.900	19.050				
	IBI-814	1.125	28.575	.751	.875	19.075	22.225				
	IBI-816	1.250	31.750	.876	1.000	22.250	25.400				



BLIND RIVETS - STANDARD

DOME HEAD

JBJSERIES - OPEN END

Body: **AISI 316 STAINLESS STEEL**

Mandrel: **AISI 316 STAINLESS STEEL**

PER IFI-114 GRADE 51

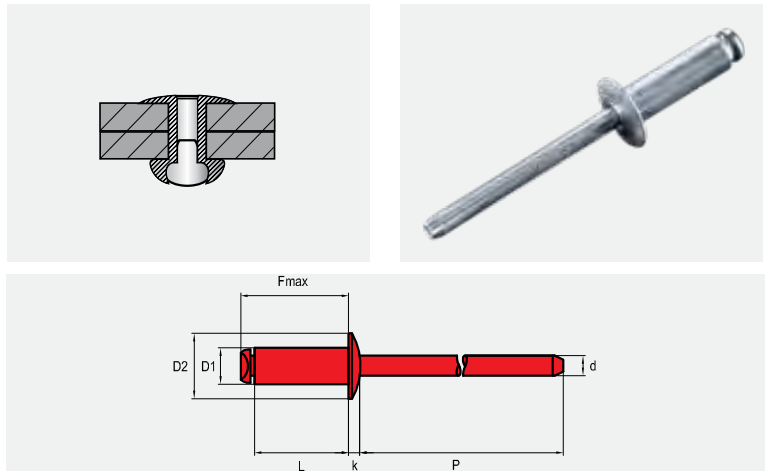

DESCRIPTION ITEM-CODE	BODY LENGTH ref.		GRIP RANGE				SHEAR		TENSILE		
	in	mm	in		mm		lbf	kn	lbf	kn	
			min	max	min	max					
1/8" (3.2 mm) D1 = 1/8" 3.2 mm D2 = .250" 6.35 mm k = .040" 1.0 mm d = .076" 1.9 mm P = ≥ 1.063" 27.0 mm .13" 3.3 mm	JBJS-41	.212	5.385	.032	.062	0.813	1.575	420	1.87	530	2.36
	JBJS-42	.275	6.985	.063	.125	1.600	3.175				
	JBJS-43	.337	8.560	.126	.187	3.200	4.750				
	JBJS-44	.400	10.160	.188	.250	4.775	6.350				
	JBJS-45	.462	11.735	.251	.312	6.375	7.925				
	JBJS-46	.525	13.335	.313	.375	7.950	9.525				
	JBJS-48	.650	16.510	.376	.500	9.550	12.700				
5/32" (4.0 mm) D1 = 5/32" 4.0 mm D2 = .315" 8.0 mm k = .050" 1.27 mm d = .095" 2.4 mm P = ≥ 1.063" 27.0 mm .161" 4.1 mm	JBJS-52	.300	7.620	.063	.125	1.600	3.175	650	2.89	820	365
	JBJS-53	.362	9.195	.126	.187	3.200	4.750				
	JBJS-54	.425	10.795	.188	.250	4.775	6.350				
	JBJS-56	.550	13.970	.251	.375	6.375	9.525				
	JBJS-58	.675	17.145	.376	.500	9.550	12.700				
3/16" (4.8 mm) D1 = 3/16" 4.8 mm D2 = .375" 9.5 mm k = .060" 1.52 mm d = .114" 2.9 mm P = ≥ 1.063" 27.0 mm .193" 4.9 mm	JBJS-62	.325	8.255	.063	.125	1.600	3.175	950	4.23	1200	5.34
	JBJS-63	.387	9.830	.126	.187	3.200	4.750				
	JBJS-64	.450	11.430	.188	.250	4.775	6.350				
	JBJS-66	.575	14.605	.251	.375	6.375	9.525				
	JBJS-68	.700	17.780	.376	.500	9.550	12.700				
	JBJS-610	.825	20.955	.501	.625	12.725	15.875				
	JBJS-612	.950	24.130	.626	.750	15.900	19.050				
	JBJS-614	1.075	27.305	.751	.875	19.075	22.225				
JBJS-616	1.200	30.480	.876	1.000	22.250	25.400					
1/4" (6.4 mm) D1 = 1/4" 6.4 mm D2 = .500" 12.7 mm k = .080" 2.0 mm d = .151" 3.84 mm P = ≥ 1.26" 32.0 mm .256" 6.5 mm	JBJS-84	.500	12.700	.126	.250	3.200	6.350	1700	7.56	2100	9.34
	JBJS-86	.625	15.875	.251	.375	6.375	9.525				
	JBJS-88	.750	19.050	.376	.500	9.550	12.700				
	JBJS-810	.875	22.225	.501	.625	12.725	15.875				
	JBJS-812	1.000	25.400	.626	.750	15.900	19.050				
	JBJS-814	1.125	28.575	.751	.875	19.075	22.225				
	JBJS-816	1.250	31.750	.876	1.000	22.250	25.400				



BLIND RIVETS - STANDARD
COUNTERSUNK HEAD 120°
 ACA-SERIES - OPEN END

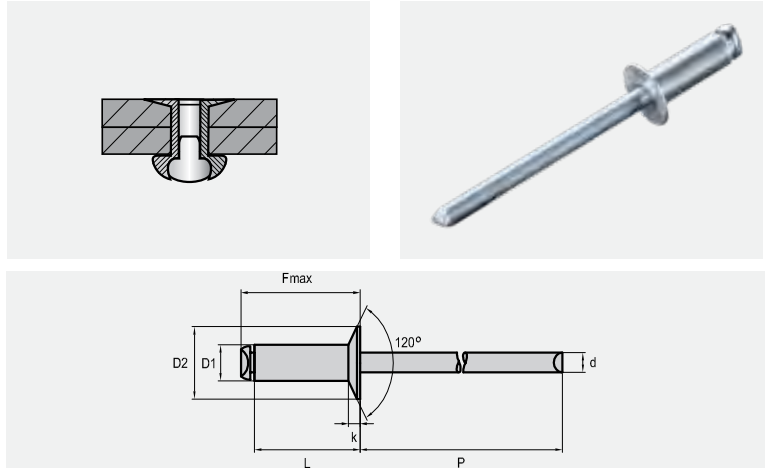

Body: **ALUMINUM**
 Mandrel: **ALUMINUM**
 PER IFI-114 GRADE 11

DESCRIPTION ITEM-CODE	BODY LENGTH ref.		GRIP RANGE				SHEAR		TENSILE		
	in	mm	in		mm		lbf	kn	lbf	kn	
			min	max	min	max					
1/8" (3.2 mm) D1 = 1/8" 3.2 mm D2 = .220" 5.6 mm k = .031" .79 mm d = .076" 1.9 mm P = ≥ 1.063" 27.0 mm .13" 3.3 mm	ACA-42	.275	6.985	.063	.125	1.600	3.175	120	0.53	150	0.67
	ACA-43	.337	8.560	.126	.187	3.200	4.750				
	ACA-44	.400	10.160	.188	.250	4.775	6.350				
	ACA-45	.462	11.735	.251	.312	6.375	7.925				
	ACA-46	.525	13.335	.313	.375	7.950	9.525				
5/32" (4.0 mm) D1 = 5/32" 4.0 mm D2 = .280" 7.1 mm k = .040" 1.0 mm d = .095" 2.4 mm P = ≥ 1.063" 27.0 mm .161" 4.1 mm	ACA-54	.425	10.795	.188	.250	4.775	6.350	190	0.85	230	1.02
	ACA-56	.550	13.970	.251	.375	6.375	9.525				
	ACA-58	.675	17.145	.376	.500	9.550	12.700				
3/16" (4.8 mm) D1 = 3/16" 4.8 mm D2 = .350" 8.9 mm k = .050" 1.27 mm d = .114" 2.9 mm P = ≥ 1.063" 27.0 mm .193" 4.9 mm	ACA-64	.450	11.430	.188	.250	4.775	6.350	260	1.16	320	1.42
	ACA-66	.575	14.605	.251	.375	6.375	9.525				
	ACA-68	.700	17.780	.376	.500	9.550	12.700				
	ACA-610	.825	20.955	.501	.625	12.725	15.875				



BLIND RIVETS - STANDARD
COUNTERSUNK HEAD 120°
 ACS-SERIES - OPEN END

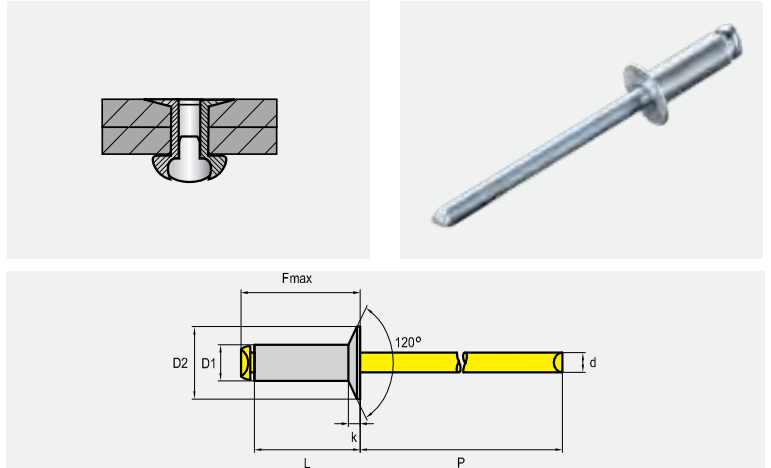

Body: **ALUMINUM**
 Mandrel: **STEEL ZINC PLATED (GALV.)**
 PER IFI-114 GRADE 16

DESCRIPTION ITEM-CODE	BODY LENGTH ref.		GRIP RANGE				SHEAR		TENSILE		
	in	mm	in		mm		lbf	kn	lbf	kn	
			min	max	min	max					
1/8" (3.2 mm) D1 = 1/8" 3.2 mm D2 = .220" 5.6 mm k = .031" .79 mm d = .076" 1.9 mm P = ≥ 1.063" 27.0 mm .13" 3.3 mm	ACS-42	.275	6.985	.063	.125	1.600	3.175	170	0.76	220	0.98
	ACS-43	.337	8.560	.126	.187	3.200	4.750				
	ACS-44	.400	10.160	.188	.250	4.775	6.350				
	ACS-45	.462	11.735	.251	.312	6.375	7.925				
	ACS-46	.525	13.335	.313	.375	7.950	9.525				
5/32" (4.0 mm) D1 = 5/32" 4.0 mm D2 = .280" 7.1 mm k = .040" 1.0 mm d = .095" 2.4 mm P = ≥ 1.063" 27.0 mm .161" 4.1 mm	ACS-52	.300	7.620	.063	.125	1.600	3.175	260	1.16	350	1.56
	ACS-53	.362	9.195	.126	.187	3.200	4.750				
	ACS-54	.425	10.795	.188	.250	4.775	6.350				
	ACS-56	.550	13.970	.251	.375	6.375	9.525				
	ACS-58	.675	17.145	.376	.500	9.550	12.700				
3/16" (4.8 mm) D1 = 3/16" 4.8 mm D2 = .350" 8.9 mm k = .050" 1.27 mm d = .114" 2.9 mm P = ≥ 1.063" 27.0 mm .193" 4.9 mm	ACS-64	.450	11.430	.188	.250	4.775	6.350	380	1.69	500	2.22
	ACS-66	.575	14.605	.251	.375	6.375	9.525				
	ACS-68	.700	17.780	.376	.500	9.550	12.700				
	ACS-610	.825	20.955	.501	.625	12.725	15.875				



BLIND RIVETS - STANDARD
COUNTERSUNK HEAD 120°
 SCS-SERIES - OPEN END

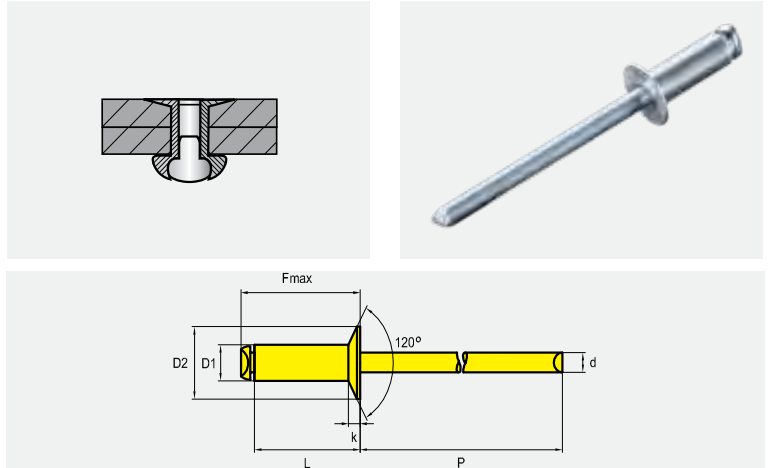

Body: **STEEL ZINC PLATED (GALV.)**
 Mandrel: **STEEL ZINC PLATED (GALV.)**
 PER IFI-114 GRADE 30

DESCRIPTION ITEM-CODE	BODY LENGTH ref.		GRIP RANGE				SHEAR		TENSILE		
	in	mm	in		mm		lbf	kn	lbf	kn	
			min	max	min	max					
1/8" (3.2 mm) D1 = 1/8" 3.2 mm D2 = .220" 5.6 mm k = .031" .79 mm d = .076" 1.9 mm P = ≥ 1.063" 27.0 mm .13" 3.3 mm	SCS-42	.275	6.985	.063	.125	1.600	3.175	260	1.16	310	1.38
	SCS-43	.337	8.560	.126	.187	3.200	4.750				
	SCS-44	.400	10.160	.188	.250	4.775	6.350				
	SCS-45	.462	11.735	.251	.312	6.375	7.925				
	SCS-46	.525	13.335	.313	.375	7.950	9.525				
5/32" (4.0 mm) D1 = 5/32" 4.0 mm D2 = .280" 7.1 mm k = .040" 1.0 mm d = .095" 2.4 mm P = ≥ 1.063" 27.0 mm .161" 4.1 mm	SCS-54	.425	10.795	.188	.250	4.775	6.350	370	1.65	470	2.09
3/16" (4.8 mm) D1 = 3/16" 4.8 mm D2 = .350" 8.9 mm k = .050" 1.27 mm d = .114" 2.9 mm P = ≥ 1.063" 27.0 mm .193" 4.9 mm	SCS-62	.325	8.255	.063	.125	1.600	3.175	540	2.40	680	3.02
	SCS-63	.387	9.830	.126	.187	3.200	4.750				
	SCS-64	.450	11.430	.188	.250	4.775	6.350				
	SCS-66	.575	14.605	.251	.375	6.375	9.525				



BLIND RIVETS - STANDARD
COUNTERSUNK HEAD 120°
 ICI-SERIES - OPEN END

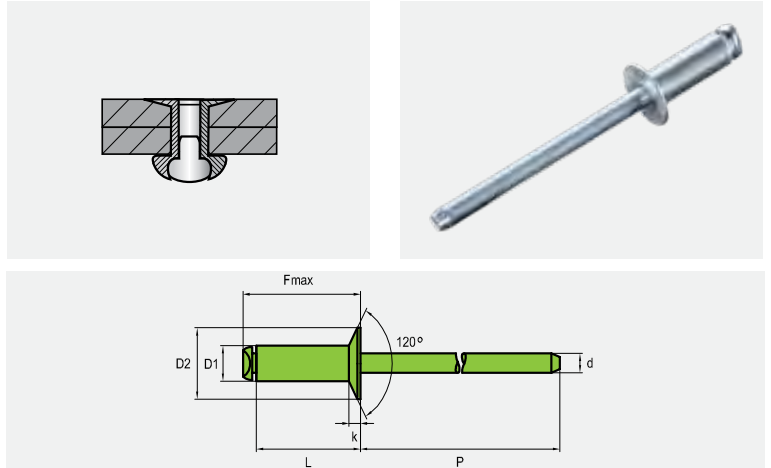

Body: **AISI 304 STAINLESS STEEL**
 Mandrel: **AISI 304 STAINLESS STEEL**
 PER IFI-114 GRADE 51

DESCRIPTION ITEM-CODE	BODY LENGTH ref.		GRIP RANGE				SHEAR		TENSILE		
	in	mm	in		mm		lbf	kn	lbf	kn	
			min	max	min	max					
1/8" (3.2 mm) D1 = 1/8" 3.2 mm D2 = .220" 5.6 mm k = .031" .79 mm d = .076" 1.9 mm P = ≥ 1.063" 27.0 mm .13" 3.3 mm	ICI-42	.275	6.985	.063	.125	1.600	3.175	420	1.87	530	2.36
	ICI-43	.337	8.560	.126	.187	3.200	4.750				
	ICI-44	.400	10.160	.188	.250	4.775	6.350				
	ICI-45	.462	11.735	.251	.312	6.375	7.925				
	ICI-46	.525	13.335	.313	.375	7.950	9.525				
5/32" (4.0 mm) D1 = 5/32" 4.0 mm D2 = .280" 7.1 mm k = .040" 1.0 mm d = .095" 2.4 mm P = ≥ 1.063" 27.0 mm .161" 4.1 mm	ICI-54	.425	10.795	.188	.250	4.775	6.350	650	2.89	820	3.65
3/16" (4.8 mm) D1 = 3/16" 4.8 mm D2 = .350" 8.9 mm k = .050" 1.27 mm d = .114" 2.9 mm P = ≥ 1.063" 27.0 mm .193" 4.9 mm	ICI-64	.450	11.430	.188	.250	4.775	6.350	950	4.23	1200	5.34
	ICI-66	.575	14.605	.251	.375	6.375	9.525				
	ICI-68	.700	17.780	.376	.500	9.550	12.700				
	ICI-610	.825	20.955	.501	.625	12.725	15.875				





BLIND RIVETS - STANDARD

LARGE FLANGE

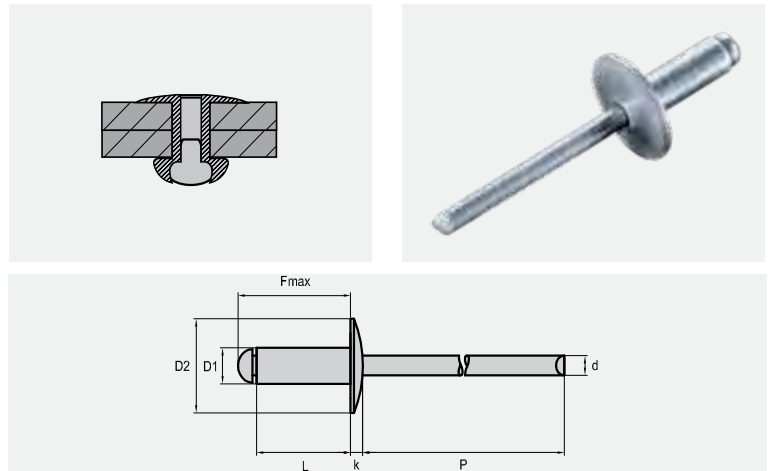
ABA-SERIES - OPEN END



Body: **ALUMINUM**
Mandrel: **ALUMINUM**
PER IFI-114 GRADE 11

DESCRIPTION ITEM-CODE	BODY LENGTH ref.		GRIP RANGE				SHEAR		TENSILE		
	in	mm	in		mm		lbf	kn	lbf	kn	
			min	max	min	max					
1/8" (3.2 mm) D1 = 1/8" 3.2 mm D2 = .375" 9.5 mm k = .065" 1.65 mm d = .076" 1.9 mm P = ≥ 1.063" 27.0 mm  .13" 3.3 mm	ABA-42LF	.275	6.985	.063	.125	1.600	3.175	120	0.53	150	0.67
	ABA-43LF	.337	8.560	.126	.187	3.200	4.750				
	ABA-44LF	.400	10.160	.188	.250	4.775	6.350				
	ABA-45LF	.462	11.735	.251	.312	6.375	7.925				
	ABA-46LF	.525	13.335	.313	.375	7.950	9.525				
	ABA-48LF	.650	16.510	.376	.500	9.550	12.700				
5/32" (4.0 mm) D1 = 5/32" 4.0 mm D2 = .470" 11.94 mm k = .075" 1.9 mm d = .095" 2.4 mm P = ≥ 1.063" 27.0 mm  .161" 4.1 mm	ABA-52LF	.300	7.620	.063	.125	1.600	3.175	190	0.85	230	1.02
	ABA-53LF	.362	9.195	.126	.187	3.200	4.750				
	ABA-54LF	.425	10.795	.188	.250	4.775	6.350				
	ABA-56LF	.550	13.970	.251	.375	6.375	9.525				
	ABA-58LF	.675	17.145	.376	.500	9.550	12.700				
3/16" (4.8 mm) D1 = 3/16" 4.8 mm D2 = .625" 15.88 mm k = .092" 2.3 mm d = .114" 2.9 mm P = ≥ 1.063" 27.0 mm  .193" 4.9 mm	ABA-62LF	.325	8.255	.063	.125	1.600	3.175	260	1.16	320	1.42
	ABA-63LF	.387	9.830	.126	.187	3.200	4.750				
	ABA-64LF	.450	11.430	.188	.250	4.775	6.350				
	ABA-66LF	.575	14.605	.251	.375	6.375	9.525				
	ABA-68LF	.700	17.780	.376	.500	9.550	12.700				
	ABA-610LF	.825	20.955	.501	.625	12.725	15.875				
	ABA-612LF	.950	24.130	.626	.750	15.900	19.050				
	ABA-614LF	1.075	27.305	.751	.875	19.075	22.225				
	ABA-616LF	1.200	30.480	.876	1.000	22.250	25.400				



BLIND RIVETS - STANDARD

LARGE FLANGE

ABS-SERIES - OPEN END

Body: **ALUMINUM**

Mandrel: **STEEL ZINC PLATED (GALV.)**

PER IFI-114 GRADE 16

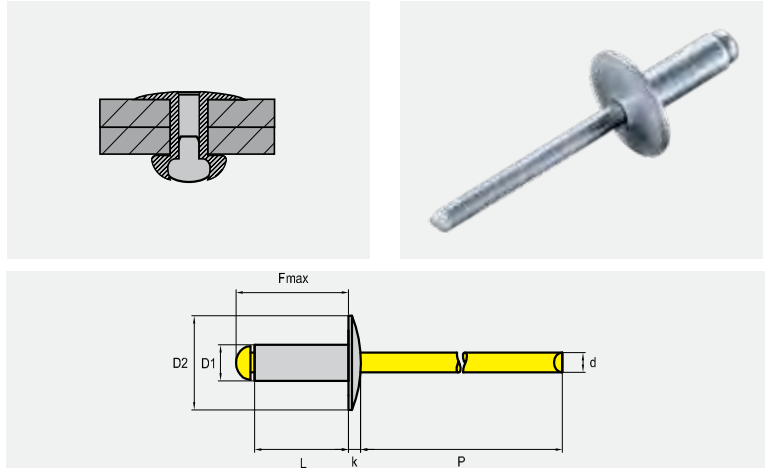

DESCRIPTION ITEM-CODE	BODY LENGTH ref.		GRIP RANGE				SHEAR		TENSILE		
	in	mm	in		mm		lbf	kn	lbf	kn	
			min	max	min	max					
1/8" (3.2 mm) D1 = 1/8" 3.2 mm D2 = .375" 9.5 mm k = .065" 1.65 mm d = .076" 1.9 mm P = ≥ 1.063" 27.0 mm .13" 3.3 mm	ABS-42LF	.275	6.985	.063	.125	1.600	3.175	170	0.76	220	0.98
	ABS-43LF	.337	8.560	.126	.187	3.200	4.750				
	ABS-44LF	.400	10.160	.188	.250	4.775	6.350				
	ABS-45LF	.462	11.735	.251	.312	6.375	7.925				
	ABS-46LF	.525	13.335	.313	.375	7.950	9.525				
	ABS-48LF	.650	16.510	.376	.500	9.550	12.700				
5/32" (4.0 mm) D1 = 5/32" 4.0 mm D2 = .470" 11.94 mm k = .075" 1.9 mm d = .095" 2.4 mm P = ≥ 1.063" 27.0 mm .161" 4.1 mm	ABS-52LF	.300	7.620	.063	.125	1.600	3.175	260	1.16	350	1.56
	ABS-53LF	.362	9.195	.126	.187	3.200	4.750				
	ABS-54LF	.425	10.795	.188	.250	4.775	6.350				
	ABS-56LF	.550	13.970	.251	.375	6.375	9.525				
3/16" (4.8 mm) D1 = 3/16" 4.8 mm D2 = .625" 15.88 mm k = .092" 2.3 mm d = .114" 2.9 mm P = ≥ 1.063" 27.0 mm .193" 4.9 mm	ABS-62LF	.325	8.255	.063	.125	1.600	3.175	380	1.69	500	2.22
	ABS-63LF	.387	9.830	.126	.187	3.200	4.750				
	ABS-64LF	.450	11.430	.188	.250	4.775	6.350				
	ABS-66LF	.575	14.605	.251	.375	6.375	9.525				
	ABS-68LF	.700	17.780	.376	.500	9.550	12.700				
	ABS-610LF	.825	20.955	.501	.625	12.725	15.875				
	ABS-612LF	.950	24.130	.626	.750	15.900	19.050				
	ABS-614LF	1.075	27.305	.751	.875	19.075	22.225				
	ABS-616LF	1.200	30.480	.876	1.000	22.250	25.400				



BLIND RIVETS - STANDARD
LARGE FLANGE
 SBS-SERIES - OPEN END

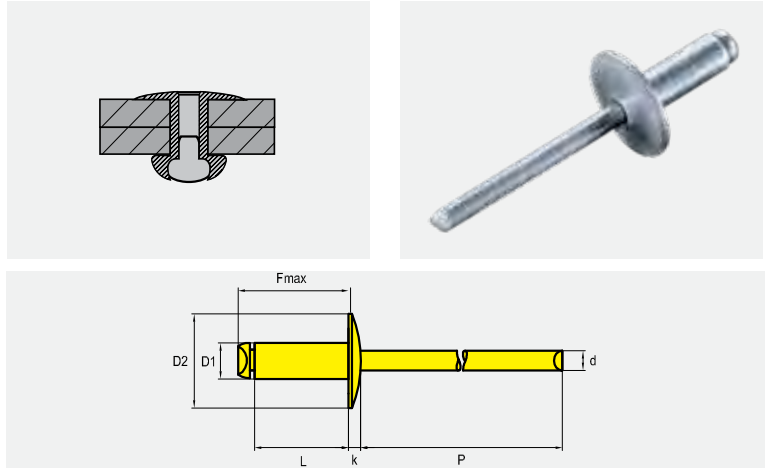

Body: **STEEL ZINC PLATED (GALV.)**
 Mandrel: **STEEL ZINC PLATED (GALV.)**
 PER IFI-114 GRADE 30

DESCRIPTION ITEM-CODE	BODY LENGTH ref.		GRIP RANGE				SHEAR		TENSILE		
	in	mm	in		mm		lbf	kn	lbf	kn	
			min	max	min	max					
1/8" (3.2 mm) D1 = 1/8" 3.2 mm D2 = .375" 9.5 mm k = .065" 1.65 mm d = .076" 1.9 mm P = ≥ 1.063" 27.0 mm .13" 3.3 mm	SBS-42LF	.275	6.985	.063	.125	1.600	3.175	260	1.16	310	1.38
	SBS-43LF	.337	8.560	.126	.187	3.200	4.750				
	SBS-44LF	.400	10.160	.188	.250	4.775	6.350				
	SBS-45LF	.462	11.735	.251	.312	6.375	7.925				
	SBS-46LF	.525	13.335	.313	.375	7.950	9.525				
	SBS-48LF	.650	16.510	.376	.500	9.550	12.700				
5/32" (4.0 mm) D1 = 5/32" 4.0 mm D2 = .470" 11.94 mm k = .075" 1.9 mm d = .095" 2.4 mm P = ≥ 1.063" 27.0 mm .161" 4.1 mm	SBS-52LF	.300	7.620	.063	.125	1.600	3.175	370	1.65	470	2.09
	SBS-53LF	.362	9.195	.126	.187	3.200	4.750				
	SBS-54LF	.425	10.795	.188	.250	4.775	6.350				
	SBS-56LF	.550	13.970	.251	.375	6.375	9.525				
	SBS-58LF	.675	17.145	.376	.500	9.550	12.700				
3/16" (4.8 mm) D1 = 3/16" 4.8 mm D2 = .625" 15.88 mm k = .092" 2.3 mm d = .114" 2.9 mm P = ≥ 1.063" 27.0 mm .193" 4.9 mm	SBS-62LF	.325	8.255	.063	.125	1.600	3.175	540	2.40	680	3.02
	SBS-63LF	.387	9.830	.126	.187	3.200	4.750				
	SBS-64LF	.450	11.430	.188	.250	4.775	6.350				
	SBS-66LF	.575	14.605	.251	.375	6.375	9.525				
	SBS-68LF	.700	17.780	.376	.500	9.550	12.700				
	SBS-610LF	.825	20.955	.501	.625	12.725	15.875				
	SBS-612LF	.950	24.130	.626	.750	15.900	19.050				
	SBS-614LF	1.075	27.305	.751	.875	19.075	22.225				
	SBS-616LF	1.200	30.480	.876	1.000	22.250	25.400				



BLIND RIVETS - STANDARD

LARGE FLANGE

IBI-SERIES - OPEN END

Body: **AISI 304 STAINLESS STEEL**
Mandrel: **AISI 304 STAINLESS STEEL**

PER IFI-114 GRADE 51

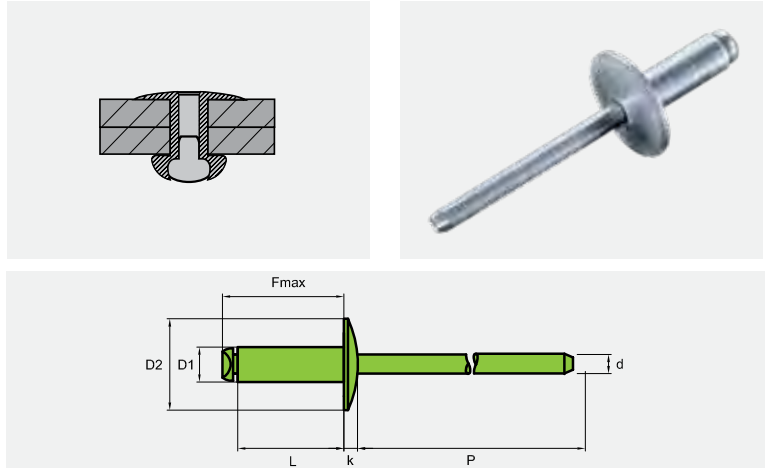

DESCRIPTION ITEM-CODE	BODY LENGTH ref.		GRIP RANGE				SHEAR		TENSILE		
	in	mm	in		mm		lbf	kn	lbf	kn	
			min	max	min	max					
1/8" (3.2 mm) D1 = 1/8" 3.2 mm D2 = .375" 9.5 mm k = .065" 1.65 mm d = .076" 1.9 mm P = ≥ 1.063" 27.0 mm .13" 3.3 mm	IBI-42LF	.275	6.985	.063	.125	1.600	3.175	420	1.87	530	2.36
	IBI-43LF	.337	8.560	.126	.187	3.200	4.750				
	IBI-44LF	.400	10.160	.188	.250	4.775	6.350				
	IBI-45LF	.462	11.735	.251	.312	6.375	7.925				
	IBI-46LF	.525	13.335	.313	.375	7.950	9.525				
	IBI-48LF	.650	16.510	.376	.500	9.550	12.700				
5/32" (4.0 mm) D1 = 5/32" 4.0 mm D2 = .470" 11.94 mm k = .075" 1.9 mm d = .095" 2.4 mm P = ≥ 1.063" 27.0 mm .161" 4.1 mm	IBI-52LF	.300	7.620	.063	.125	1.600	3.175	650	2.89	820	3.65
	IBI-53LF	.362	9.195	.126	.187	3.200	4.750				
	IBI-54LF	.425	10.795	.188	.250	4.775	6.350				
	IBI-56LF	.550	13.970	.251	.375	6.375	9.525				
3/16" (4.8 mm) D1 = 3/16" 4.8 mm D2 = .625" 15.88 mm k = .092" 2.3 mm d = .114" 2.9 mm P = ≥ 1.063" 27.0 mm .193" 4.9 mm	IBI-62LF	.325	8.255	.063	.125	1.600	3.175	950	4.23	1200	5.34
	IBI-63LF	.387	9.830	.126	.187	3.200	4.750				
	IBI-64LF	.450	11.430	.188	.250	4.775	6.350				
	IBI-66LF	.575	14.605	.251	.375	6.375	9.525				
	IBI-68LF	.700	17.780	.376	.500	9.550	12.700				
	IBI-610LF	.825	20.955	.501	.625	12.725	15.875				
	IBI-612LF	.950	24.130	.626	.750	15.900	19.050				
	IBI-614LF	1.075	27.305	.751	.875	19.075	22.225				
IBI-616LF	1.200	30.480	.876	1.000	22.250	25.400					



SEALED BLIND RIVETS - CUP

DOME HEAD

ABA-CE-SERIES - CLOSED END

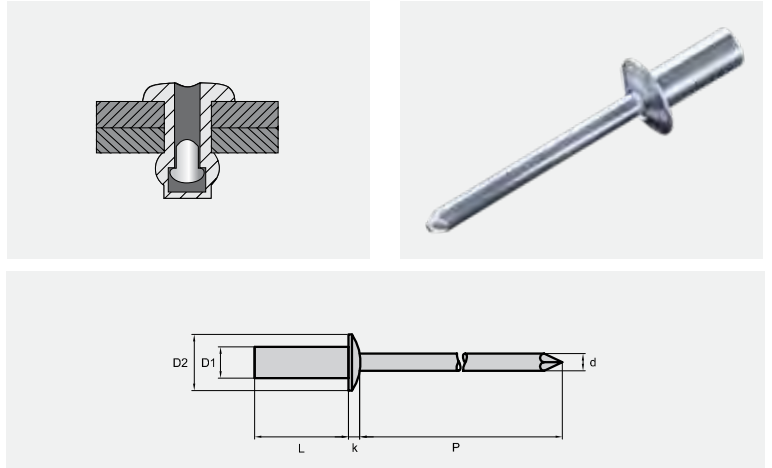

Body: **ALUMINUM**
Mandrel: **ALUMINUM**

PER IFI-126 GRADE 9

DESCRIPTION ITEM-CODE	BODY LENGTH ref.		GRIP RANGE				SHEAR		TENSILE		
	in	mm	in		mm		lbf	kn	lbf	kn	
			min	max	min	max					
1/8" (3.2 mm) D1 = 1/8" 3.2 mm D2 = .240" 6.01 mm k = .050" 1.27 mm d = .074" 1.88 mm P = ≥ 1.063" 27.0 mm .13" 3.3 mm	ABA-41-CE	.297	7.544	.020	.062	0.508	1.575	100	0.44	110	0.49
	ABA-42-CE	.360	9.144	.063	.125	1.600	3.175				
	ABA-43-CE	.422	10.719	.126	.187	3.200	4.750				
	ABA-44-CE	.485	12.319	.188	.250	4.775	6.350				
	ABA-45-CE	.547	13.894	.251	.312	6.375	7.925				
	ABA-46-CE	.610	15.494	.313	.375	7.950	9.525				
	ABA-48-CE	.735	18.669	.376	.500	9.550	12.700				
5/32" (4.0 mm) D1 = 5/32" 4.0 mm D2 = .315" 8.0 mm k = .065" 1.65 mm d = .092" 2.34 mm P = ≥ 1.063" 27.0 mm .161" 4.1 mm	ABA-52-CE	.375	9.525	.020	.125	0.508	3.175	130	0.58	160	0.71
	ABA-53-CE	.437	11.100	.126	.187	3.200	4.750				
	ABA-54-CE	.500	12.700	.188	.250	4.775	6.350				
	ABA-55-CE	.562	14.275	.251	.312	6.375	7.925				
	ABA-56-CE	.625	15.875	.313	.375	7.950	9.525				
	ABA-58-CE	.750	19.050	.376	.500	9.550	12.700				
3/16" (4.8 mm) D1 = 3/16" 4.8 mm D2 = .375" 9.53 mm k = .080" 2.03 mm d = .110" 2.8 mm P = ≥ 1.063" 27.0 mm .193" 4.9 mm	ABA-62-CE	.406	10.312	.020	.125	0.508	3.175	210	0.93	250	1.11
	ABA-63-CE	.468	11.887	.126	.187	3.200	4.750				
	ABA-64-CE	.531	13.487	.188	.250	4.775	6.350				
	ABA-66-CE	.656	16.662	.251	.375	6.375	9.525				
	ABA-68-CE	.781	19.837	.376	.500	9.550	12.700				
	ABA-610-CE	.906	23.012	.501	.625	12.725	15.875				
	ABA-612-CE	1.026	26.060	.626	.750	15.900	19.050				



SEALED BLIND RIVETS - CUP

DOME HEAD

ABS-CE-SERIES - CLOSED END

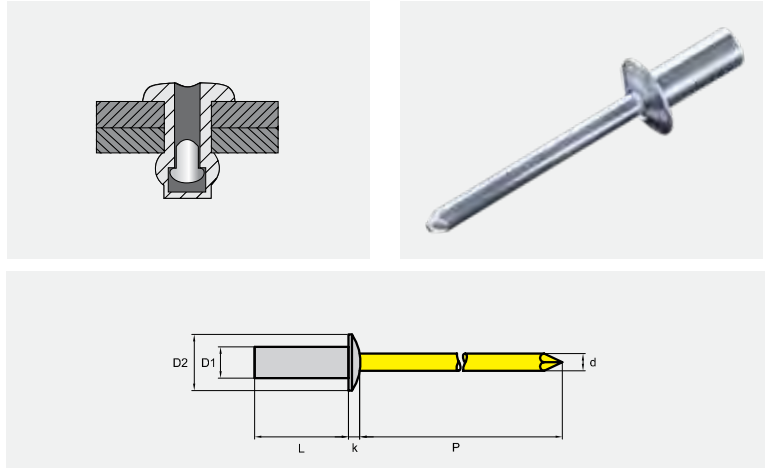

Body: **ALUMINUM**

Mandrel: **STEEL PROTECTION LAYER**

PER IFI-126 GRADE 19

DESCRIPTION ITEM-CODE	BODY LENGTH ref.		GRIP RANGE				SHEAR		TENSILE		
	in	mm	in		mm		lbf	kn	lbf	kn	
			min	max	min	max					
1/8" (3.2 mm) D1 = 1/8" 3.2 mm D2 = .240" 6.01 mm k = .050" 1.27 mm d = .074" 1.88 mm P = ≥ 1.063" 27.0 mm .13" 3.3 mm	ABS-41-CE	.297	7.544	.020	.062	0.508	1.575	240	1.07	280	1.25
	ABS-42-CE	.360	9.144	.063	.125	1.600	3.175				
	ABS-43-CE	.422	10.719	.126	.187	3.200	4.750				
	ABS-44-CE	.485	12.319	.188	.250	4.775	6.350				
	ABS-45-CE	.547	13.894	.251	.312	6.375	7.925				
	ABS-46-CE	.610	15.494	.313	.375	7.950	9.525				
	ABS-48-CE	.735	18.669	.376	.500	9.550	12.700				
5/32" (4.0 mm) D1 = 5/32" 4.0 mm D2 = .315" 8.0 mm k = .065" 1.65 mm d = .092" 2.34 mm P = ≥ 1.063" 27.0 mm .161" 4.1 mm	ABS-52-CE	.375	9.525	.020	.125	0.508	3.175	350	1.56	480	2.14
	ABS-53-CE	.437	11.100	.126	.187	3.200	4.750				
	ABS-54-CE	.500	12.700	.188	.250	4.775	6.350				
	ABS-55-CE	.562	14.275	.251	.312	6.375	7.925				
	ABS-56-CE	.625	15.875	.313	.375	7.950	9.525				
	ABS-58-CE	.750	19.050	.376	.500	9.550	12.700				
3/16" (4.8 mm) D1 = 3/16" 4.8 mm D2 = .375" 9.53 mm k = .080" 2.03 mm d = .110" 2.8 mm P = ≥ 1.063" 27.0 mm .193" 4.9 mm	ABS-62-CE	.406	10.312	.020	.125	0.508	3.175	500	2.22	690	3.07
	ABS-63-CE	.468	11.887	.126	.187	3.200	4.750				
	ABS-64-CE	.531	13.487	.188	.250	4.775	6.350				
	ABS-66-CE	.656	16.662	.251	.375	6.375	9.525				
	ABS-68-CE	.781	19.837	.376	.500	9.550	12.700				
	ABS-610-CE	.906	23.012	.501	.625	12.725	15.875				
	ABS-612-CE	1.026	26.060	.626	.750	15.900	19.050				
1/4" (6.4 mm) D1 = 1/4" 6.4 mm D2 = .500" 12.7 mm k = .100" 2.54 mm d = .146" 3.7 mm P = ≥ 1.22" 31.0 mm .256" 6.5 mm	ABS-82-CE	.445	11.303	.020	.125	0.508	3.175	900	4.00	1100	4.89
	ABS-84-CE	.570	14.478	.126	.250	3.200	6.350				
	ABS-86-CE	.695	17.653	.251	.375	6.375	9.525				
	ABS-88-CE	.820	20.828	.376	.500	9.550	12.700				
	ABS-810-CE	.945	24.003	.501	.625	12.725	15.875				
	ABS-812-CE	1.070	27.178	.626	.750	15.900	19.050				
	ABS-814-CE	1.195	30.353	.751	.875	19.075	22.225				
	ABS-816-CE	1.320	33.528	.876	1.000	22.250	25.400				



SEALED BLIND RIVETS - CUP

DOME HEAD

ABI-CE-SERIES - CLOSED END

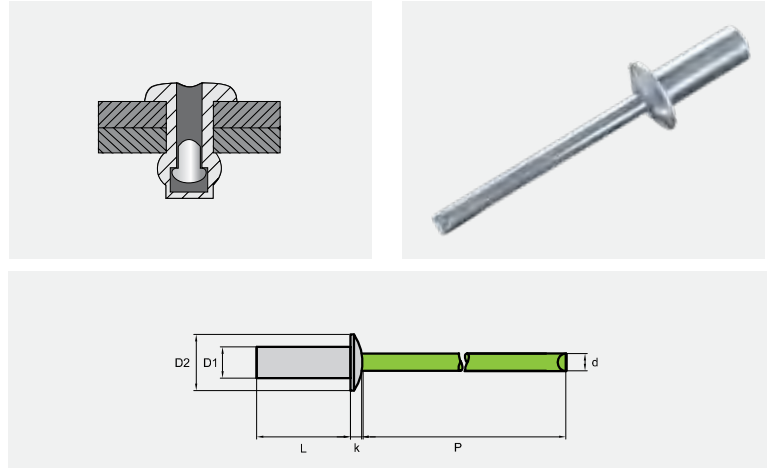

Body: **ALUMINUM**

Mandrel: **AISI 304 STAINLESS STEEL**

PER IFI-126 GRADE 26

DESCRIPTION ITEM-CODE	BODY LENGTH ref.		GRIP RANGE				SHEAR		TENSILE		
	in	mm	in		mm		lbf	kn	lbf	kn	
			min	max	min	max					
1/8" (3.2 mm) D1 = 1/8" 3.2 mm D2 = .240" 6.01 mm k = .050" 1.27 mm d = .074" 1.88 mm P = ≥ 1.063" 27.0 mm .13" 3.3 mm	ABI-42-CE	.360	9.144	.020	.125	0.508	3.175	240	1.07	280	1.25
ABI-43-CE	.422	10.719	.126	.187	3.200	4.750					
ABI-44-CE	.485	12.319	.188	.250	4.775	6.350					
ABI-45-CE	.547	13.894	.251	.312	6.375	7.925					
5/32" (4.0 mm) D1 = 5/32" 4.0 mm D2 = .315" 8.0 mm k = .065" 1.65 mm d = .092" 2.34 mm P = ≥ 1.063" 27.0 mm .161" 4.1 mm	ABI-52-CE	.375	9.525	.020	.125	0.508	3.175	350	1.56	480	2.14
ABI-53-CE	.437	11.100	.126	.187	3.200	4.750					
ABI-54-CE	.500	12.700	.188	.250	4.775	6.350					
ABI-55-CE	.562	14.275	.251	.312	6.375	7.925					
ABI-56-CE	.625	15.875	.313	.375	7.950	9.525					
3/16" (4.8 mm) D1 = 3/16" 4.8 mm D2 = .375" 9.53 mm k = .080" 2.03 mm d = .110" 2.8 mm P = ≥ 1.063" 27.0 mm .193" 4.9 mm	ABI-62-CE	.406	10.312	.020	.125	0.508	3.175	500	2.22	690	3.07
ABI-63-CE	.468	11.887	.126	.187	3.200	4.750					
ABI-64-CE	.531	13.487	.188	.250	4.775	6.350					
ABI-66-CE	.656	16.662	.251	.375	6.375	9.525					
ABI-68-CE	.781	19.837	.376	.500	9.550	12.700					
ABI-610-CE	.906	23.012	.501	.625	12.725	15.875					



SEALED BLIND RIVETS - CUP



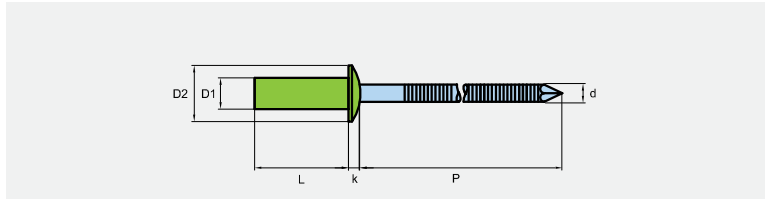
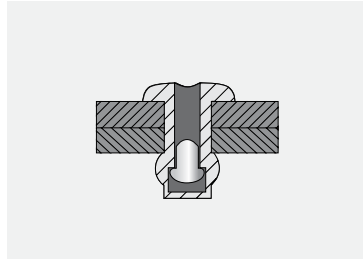

DOME HEAD

IBM-CE-SERIES - CLOSED END



Body: **AISI 304 STAINLESS STEEL**
Mandrel: **AISI 420 STAINLESS STEEL**

PER IFI-126 GRADE 51

DESCRIPTION ITEM-CODE	BODY LENGTH ref.		GRIP RANGE				SHEAR		TENSILE		
	in	mm	in		mm		lbf	kn	lbf	kn	
			min	max	min	max					
1/8" (3.2 mm) D1 = 1/8" 3.2 mm D2 = .240" 6.01 mm k = .050" 1.27 mm d = .074" 1.88 mm P = ≥ 1.063" 27.0 mm  .13" 3.3 mm	IBM-41-CE	.297	7.544	.020	.062	0.508	1.575	400	1.78	450	2.00
	IBM-42-CE	.360	9.144	.063	.125	1.600	3.175				
	IBM-43-CE	.422	10.719	.126	.187	3.200	4.750				
	IBM-44-CE	.485	12.319	.188	.250	4.775	6.350				
	IBM-45-CE	.547	13.894	.251	.312	6.375	7.925				
	IBM-46-CE	.610	15.494	.313	.375	7.950	9.525				
	IBM-48-CE	.735	18.669	.376	.500	9.550	12.700				
5/32" (4.0 mm) D1 = 5/32" 4.0 mm D2 = .315" 8.0 mm k = .065" 1.65 mm d = .092" 2.34 mm P = ≥ 1.063" 27.0 mm  .161" 4.1 mm	IBM-52-CE	.375	9.525	.020	.125	0.508	3.175	700	3.11	800	3.56
	IBM-53-CE	.437	11.100	.126	.187	3.200	4.750				
	IBM-54-CE	.500	12.700	.188	.250	4.775	6.350				
	IBM-55-CE	.562	14.275	.251	.312	6.375	7.925				
	IBM-56-CE	.625	15.875	.313	.375	7.950	9.525				
	IBM-58-CE	.750	19.050	.376	.500	9.550	12.700				
3/16" (4.8 mm) D1 = 3/16" 4.8 mm D2 = .375" 9.53 mm k = .080" 2.03 mm d = .110" 2.8 mm P = ≥ 1.063" 27.0 mm  .193" 4.9 mm	IBM-62-CE	.406	10.312	.020	.125	0.508	3.175	850	3.78	900	4.00
	IBM-63-CE	.468	11.887	.126	.187	3.200	4.750				
	IBM-64-CE	.531	13.487	.188	.250	4.775	6.350				
	IBM-66-CE	.656	16.662	.251	.375	6.375	9.525				
	IBM-68-CE	.781	19.837	.376	.500	9.550	12.700				
	IBM-610-CE	.906	23.012	.501	.625	12.725	15.875				
	IBM-612-CE	1.026	26.060	.626	.750	15.900	19.050				
1/4" (6.4 mm) D1 = 1/4" 6.4 mm D2 = .500" 12.7 mm k = .100" 2.54 mm d = .146" 3.7 mm P = ≥ 1.26" 32.0 mm  .256" 6.5 mm	IBM-84-CE	.570	14.478	.126	.250	3.200	6.350	1525	6.78	1950	8.67
	IBM-86-CE	.695	17.653	.251	.375	6.375	9.525				
	IBM-88-CE	.820	20.828	.376	.500	9.550	12.700				



SEALED BLIND RIVETS - CUP

DOME HEAD

JBD-CE-SERIES - CLOSED END

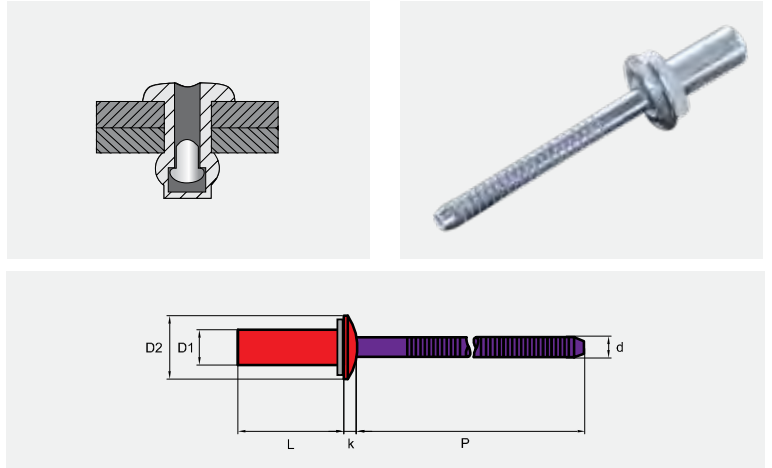

Body: **AISI 316 STAINLESS STEEL**
 Mandrel: **AISI 318 LN STAINLESS STEEL**
 Washer: **HNBR**

PER IFI-126 GRADE 51

DESCRIPTION ITEM-CODE	BODY LENGTH ref.		GRIP RANGE				SHEAR		TENSILE		
	in	mm	in		mm		lbf	kn	lbf	kn	
			min	max	min	max					
1/8" (3.2 mm) D1 = 1/8" 3.2 mm D2 = .240" 6.01 mm k = .050" 1.27 mm d = .074" 1.88 mm P = ≥ 1.063" 27.0 mm .13" 3.3 mm	JBD-41-CE	.297	7.544	.020	.062	0.508	1.575	525	2.34	635	2.82
JBD-42-CE	.360	9.144	.063	.125	1.600	3.175					
JBD-43-CE	.422	10.719	.126	.187	3.200	4.750					
JBD-44-CE	.485	12.319	.188	.250	4.775	6.350					
JBD-45-CE	.547	13.894	.251	.312	6.375	7.925					
JBD-46-CE	.610	15.494	.313	.375	7.950	9.525					
JBD-48-CE	.735	18.669	.376	.500	9.550	12.700					
5/32" (4.0 mm) D1 = 5/32" 4.0 mm D2 = .315" 8.0 mm k = .065" 1.65 mm d = .092" 2.34 mm P = ≥ 1.063" 27.0 mm .161" 4.1 mm	JBD-52-CE	.375	9.525	.020	.125	0.508	3.175	790	3.51	1230	5.47
JBD-53-CE	.437	11.100	.126	.187	3.200	4.750					
JBD-54-CE	.500	12.700	.188	.250	4.775	6.350					
JBD-55-CE	.562	14.275	.251	.312	6.375	7.925					
JBD-56-CE	.625	15.875	.313	.375	7.950	9.525					
JBD-58-CE	.750	19.050	.376	.500	9.550	12.700					
3/16" (4.8 mm) D1 = 3/16" 4.8 mm D2 = .375" 9.53 mm k = .080" 2.03 mm d = .110" 2.8 mm P = ≥ 1.063" 27.0 mm .193" 4.9 mm	JBD-62-CE	.406	10.312	.020	.125	0.508	3.175	1220	5.43	1540	6.85
JBD-63-CE	.468	11.887	.126	.187	3.200	4.750					
JBD-64-CE	.531	13.487	.188	.250	4.775	6.350					
JBD-66-CE	.656	16.662	.251	.375	6.375	9.525					
JBD-68-CE	.781	19.837	.376	.500	9.550	12.700					
JBD-610-CE	.906	23.012	.501	.625	12.725	15.875					



SEALED BLIND RIVETS - CUP

COUNTERSUNK HEAD

ACS-CE-SERIES - CLOSED END

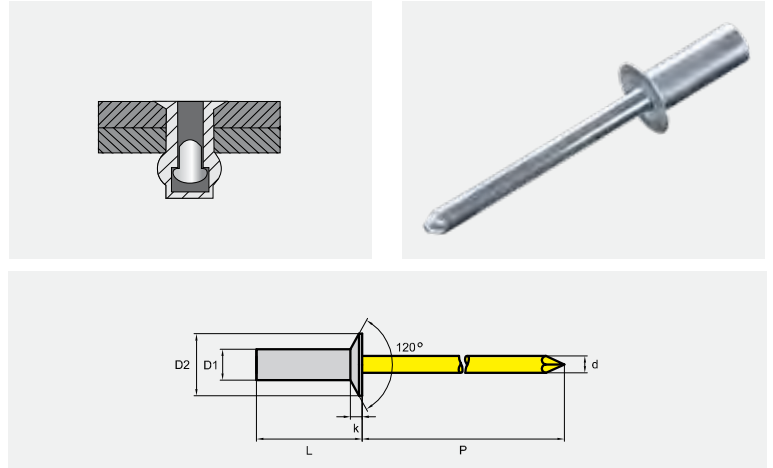

Body: **ALUMINUM**

Mandrel: **STEEL PROTECTION LAYER**

PER IFI-126 GRADE 19

DESCRIPTION ITEM-CODE	BODY LENGTH ref.		GRIP RANGE				SHEAR		TENSILE		
	in	mm	in		mm		lbf	kn	lbf	kn	
			min	max	min	max					
1/8" (3.2 mm) D1 = 1/8" 3.2 mm D2 = .230" 5.84 mm k = .042" 1.07 mm d = .074" 1.88 mm P = ≥ 1.063" 27.0 mm .13" 3.3 mm	ACS-41-CE	.332	8.433	.031	.062	0.787	1.575	240	1.07	280	1.25
	ACS-42-CE	.395	10.033	.063	.125	1.600	3.175				
	ACS-43-CE	.457	11.608	.126	.187	3.200	4.750				
	ACS-44-CE	.520	13.208	.188	.250	4.775	6.350				
	ACS-45-CE	.582	14.783	.251	.312	6.375	7.925				
	ACS-46-CE	.645	16.383	.313	.375	7.950	9.525				
5/32" (4.0 mm) D1 = 5/32" 4.0 mm D2 = .310" 7.88 mm k = .051" 1.3 mm d = .092" 2.34 mm P = ≥ 1.063" 27.0 mm .161" 4.1 mm	ACS-52-CE	.425	10.795	.063	.125	1.600	3.175	350	1.56	480	2.14
	ACS-53-CE	.487	12.370	.126	.187	3.200	4.750				
	ACS-54-CE	.550	13.970	.188	.250	4.775	6.350				
	ACS-55-CE	.612	15.545	.251	.312	6.375	7.925				
3/16" (4.8 mm) D1 = 3/16" 4.8 mm D2 = .375" 9.53 mm k = .060" 1.52 mm d = .110" 2.8 mm P = ≥ 1.063" 27.0 mm .193" 4.9 mm	ACS-62-CE	.471	11.963	.063	.125	1.600	3.175	500	2.22	690	3.07
	ACS-63-CE	.538	13.665	.126	.187	3.200	4.750				
	ACS-64-CE	.601	15.265	.188	.250	4.775	6.350				
	ACS-66-CE	.736	18.694	.251	.375	6.375	9.525				



SEALED BLIND RIVETS - CUP
COUNTERSUNK HEAD
 ACI-CE-SERIES - CLOSED END

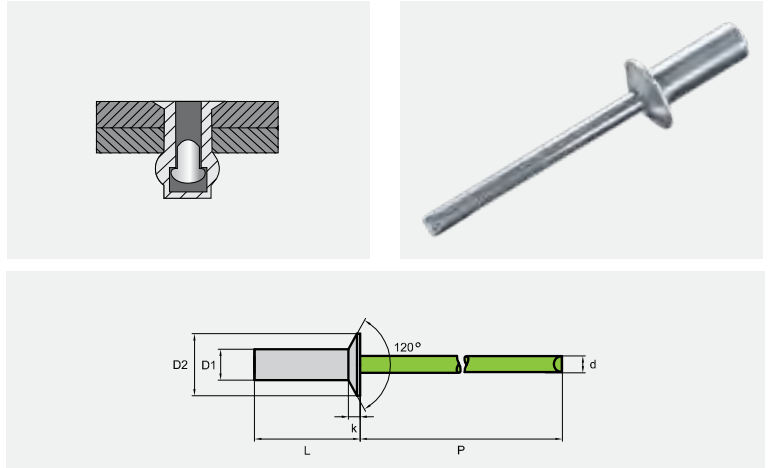

Body: **ALUMINUM**
 Mandrel: **AISI 304 STAINLESS STEEL**
 PER IFI-126 GRADE 26

DESCRIPTION ITEM-CODE	BODY LENGTH ref.		GRIP RANGE				SHEAR		TENSILE		
	in	mm	in		mm		lbf	kn	lbf	kn	
			min	max	min	max					
1/8" (3.2 mm) D1 = 1/8" 3.2 mm D2 = .230" 5.84 mm k = .042" 1.07 mm d = .074" 1.88 mm P = ≥ 1.063" 27.0 mm ⌀ .13" 3.3 mm	ACI-41-CE	.332	8.433	.031	.062	0.787	1.575	240	1.07	280	1.25
ACI-42-CE	.395	10.033	.063	.125	1.600	3.175					
ACI-43-CE	.457	11.608	.126	.187	3.200	4.750					
ACI-44-CE	.520	13.208	.188	.250	4.775	6.350					
5/32" (4.0 mm) D1 = 5/32" 4.0 mm D2 = .310" 7.88 mm k = .051" 1.3 mm d = .092" 2.34 mm P = ≥ 1.063" 27.0 mm ⌀ .161" 4.1 mm	ACI-52-CE	.425	10.795	.063	.125	1.600	3.175	350	1.56	480	2.14
ACI-53-CE	.487	12.370	.126	.187	3.200	4.750					
ACI-54-CE	.550	13.970	.188	.250	4.775	6.350					
ACI-55-CE	.612	15.545	.251	.312	6.375	7.925					
3/16" (4.8 mm) D1 = 3/16" 4.8 mm D2 = .375" 9.53 mm k = .060" 1.52 mm d = .110" 2.8 mm P = ≥ 1.063" 27.0 mm ⌀ .193" 4.9 mm	ACI-62-CE	.471	11.963	.063	.125	1.600	3.175	500	2.22	690	3.07
ACI-63-CE	.538	13.665	.126	.187	3.200	4.750					
ACI-64-CE	.601	15.265	.188	.250	4.775	6.350					
ACI-66-CE	.736	18.694	.251	.375	6.375	9.525					



MULTI-GRIP BLIND RIVETS - MULTI

DOME HEAD

ABS-MGCT-SERIES - MULTI-CT

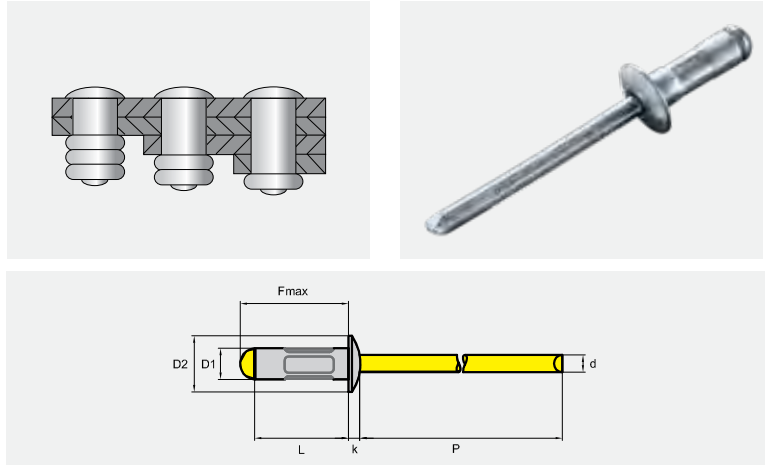

Body: **ALUMINUM**

Mandrel: **STEEL ZINC PLATED (GALV.)**

DESCRIPTION ITEM-CODE	F-MAX		GRIP RANGE				SHEAR		TENSILE		
	in	mm	in		mm		lbf	kn	lbf	kn	
			min	max	min	max					
1/8" (3.2 mm) D1 = 1/8" 3.2 mm D2 = .250" 6.35 mm k = .040" 1.0 mm d = .076" 1.9 mm P = ≥ 1.063" 27.0 mm .13" 3.3 mm	ABS-41-43MGCT	.410	10.414	.031	.187	0.787	4.750	165	0.73	230	1.02
	ABS-42-44MGCT	.470	11.938	.047	.250	1.194	6.350				
	ABS-43-45MGCT	.540	13.716	.157	.312	3.988	7.925				
	ABS-44-46MGCT	.630	16.002	.219	.375	5.563	9.525				

5/32" (4.0 mm) D1 = 5/32" 4.0 mm D2 = .315" 8.0 mm k = .050" 1.27 mm d = .095" 2.4 mm P = ≥ 1.063" 27.0 mm .161" 4.1 mm	ABS-51-53MGCT	.420	10.668	.031	.187	0.787	4.750	255	1.13	375	1.67
	ABS-52-54MGCT	.490	12.446	.047	.250	1.194	6.350				
	ABS-53-56MGCT	.640	16.256	.157	.375	3.988	9.525				
	ABS-54-58MGCT	.770	19.558	.250	.500	6.350	12.700				

3/16" (4.8 mm) D1 = 3/16" 4.8 mm D2 = .375" 9.5 mm k = .060" 1.52 mm d = .114" 2.9 mm P = ≥ 1.063" 27.0 mm .193" 4.9 mm	ABS-62-64MGCT	.550	13.970	.062	.250	1.575	6.350	345	1.53	525	2.34
	ABS-63-67MGCT	.740	18.796	.187	.437	4.750	11.100				
	ABS-64-68MGCT	.800	20.320	.250	.500	6.350	12.700				
	ABS-68-612MGCT	1.110	28.194	.500	.781	12.700	19.837				

1/4" (6.4 mm) D1 = 1/4" 6.4 mm D2 = .515" 13.08 mm k = .100" 2.54 mm d = .155" 3.94 mm P = ≥ 1.26" 32.0 mm .256" 6.5 mm	ABS-82-85MGCT	.660	16.764	.060	.325	1.524	8.255	700	3.11	560	2.49
--	---------------	------	--------	------	------	-------	-------	-----	------	-----	------



MULTI-GRIP BLIND RIVETS - MULTI

DOME HEAD

ABI-MGCT-SERIES - MULTI-CT

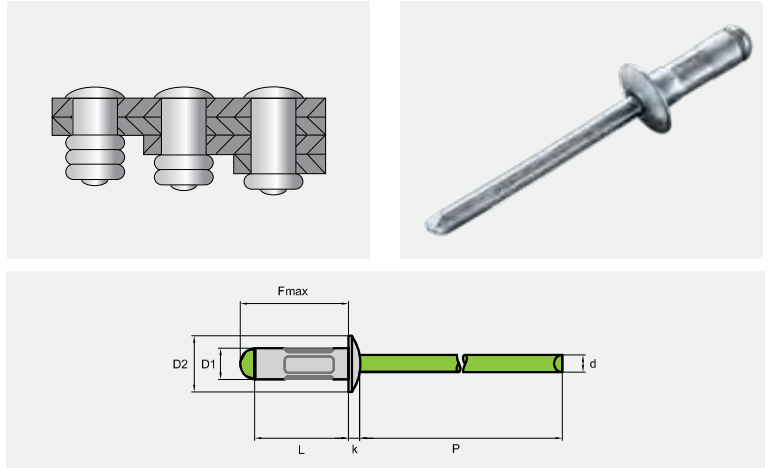

Body: **ALUMINUM**

Mandrel: **AISI 304 STAINLESS STEEL**

DESCRIPTION ITEM-CODE	F-MAX		GRIP RANGE				SHEAR		TENSILE		
	in	mm	in		mm		lbf	kn	lbf	kn	
			min	max	min	max					
1/8" (3.2 mm) D1 = 1/8" 3.2 mm D2 = .250" 6.35 mm k = .040" 1.0 mm d = .076" 1.9 mm P = ≥ 1.063" 27.0 mm .13" 3.3 mm	ABI-41-43MGCT	.410	10.414	.032	.187	0.813	4.750	165	0.73	230	1.02
ABI-42-44MGCT	.470	11.938	.047	.250	1.194	6.350					
ABI-43-45MGCT	.540	13.716	.157	.312	3.988	7.925					
ABI-44-46MGCT	.630	16.002	.219	.375	5.563	9.525					
5/32" (4.0 mm) D1 = 5/32" 4.0 mm D2 = .315" 8.0 mm k = .050" 1.27 mm d = .095" 2.4 mm P = ≥ 1.063" 27.0 mm .161" 4.1 mm	ABI-51-53MGCT	.420	10.668	.032	.187	0.813	4.750	255	1.13	375	1.67
ABI-52-54MGCT	.490	12.446	.047	.250	1.194	6.350					
ABI-53-56MGCT	.640	16.256	.157	.375	3.988	9.525					
ABI-54-58MGCT	.770	19.558	.250	.500	6.350	12.700					
3/16" (4.8 mm) D1 = 3/16" 4.8 mm D2 = .375" 9.5 mm k = .060" 1.52 mm d = .114" 2.9 mm P = ≥ 1.063" 27.0 mm .193" 4.9 mm	ABI-62-64MGCT	.550	13.970	.063	.250	1.600	6.350	345	1.53	525	2.34
ABI-63-67MGCT	.740	18.796	.187	.437	4.750	11.100					
ABI-64-68MGCT	.800	20.320	.250	.500	6.350	12.700					
ABI-68-612MGCT	1.110	28.194	.500	.781	12.700	19.837					



MULTI-GRIP BLIND RIVETS - MULTI

DOME HEAD

SBS-MGRT-SERIES - MULTI-RT

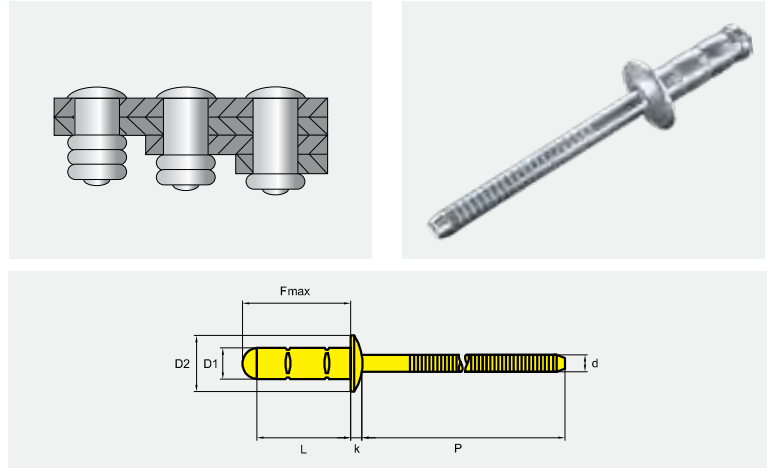

Body: **STEEL ZINC PLATED (GALV.)**
Mandrel: **STEEL ZINC PLATED (GALV.)**

DESCRIPTION ITEM-CODE	F-MAX		GRIP RANGE				SHEAR		TENSILE	
	in	mm	in		mm		lbf	kn	lbf	kn
			min	max	min	max				

1/8" (3.2 mm)
D1 = 1/8" 3.2 mm
D2 = .250" 6.35 mm
k = .040" 1.0 mm
d = .076" 1.9 mm
P = ≥ 1.063" 27.0 mm
 .13" 3.3 mm

SBS-41-43MGRT	.570	14.478	.039	.236	0.991	5.994	200	0.89	265	1.18
---------------	------	--------	------	------	-------	-------	-----	------	-----	------

5/32" (4.0 mm)
D1 = 5/32" 4.0 mm
D2 = .315" 8.0 mm
k = .050" 1.27 mm
d = .095" 2.4 mm
P = ≥ 1.063" 27.0 mm
 .161" 4.1 mm

SBS-52-55MGRT	.630	16.002	.079	.315	2.007	8.001	345	1.53	405	1.80
---------------	------	--------	------	------	-------	-------	-----	------	-----	------

3/16" (4.8 mm)
D1 = 3/16" 4.8 mm
D2 = .375" 9.5 mm
k = .060" 1.52 mm
d = .114" 2.9 mm
P = ≥ 1.063" 27.0 mm
 .193" 4.9 mm

SBS-62-64MGRT	.540	13.716	.060	.250	1.524	6.350	540	2.40	645	2.87
SBS-62-65MGRT	.670	17.018	.060	.354	1.524	8.992				
SBS-64-68MGRT	.790	20.066	.250	.500	6.350	12.700				

1/4" (6.4 mm)
D1 = 1/4" 6.4 mm
D2 = .515" 13.08 mm
k = .100" 2.54 mm
d = .155" 3.94 mm
P = ≥ 1.26" 32.0 mm
 .256" 6.5 mm

SBS-82-84MGRT	.660	16.764	.060	.300	1.524	7.620	700	3.11	800	3.56
---------------	------	--------	------	------	-------	-------	-----	------	-----	------



MULTI-GRIP BLIND RIVETS - MULTI

DOME HEAD

IBI-MGRT-SERIES - MULTI-RT

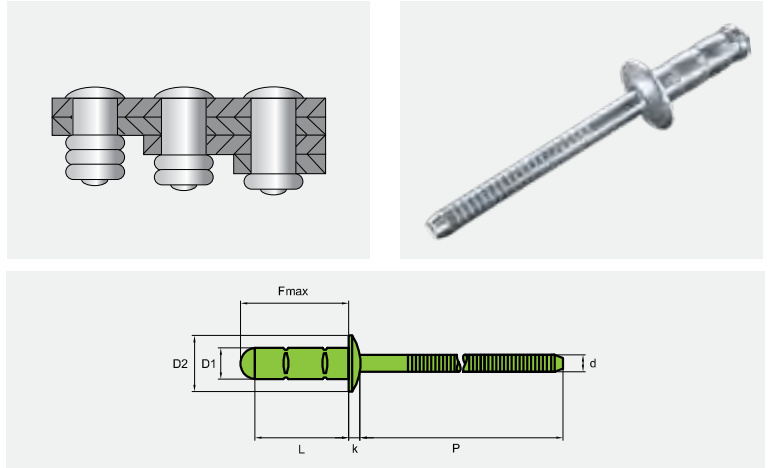

Body: **AISI 304 STAINLESS STEEL**
Mandrel: **AISI 304 STAINLESS STEEL**

DESCRIPTION ITEM-CODE	F-MAX		GRIP RANGE				SHEAR		TENSILE		
	in	mm	in		mm		lbf	kn	lbf	kn	
			min	max	min	max					
1/8" (3.2 mm) D1 = 1/8" 3.2 mm D2 = .250" 6.35 mm k = .040" 1.0 mm d = .076" 1.9 mm P = ≥ 1.063" 27.0 mm .13" 3.3 mm	IBI-41-43MGRT	.570	14.478	.039	.236	0.991	5.994	325	1.45	445	1.98
5/32" (4.0 mm) D1 = 5/32" 4.0 mm D2 = .315" 8.0 mm k = .050" 1.27 mm d = .095" 2.4 mm P = ≥ 1.063" 27.0 mm .161" 4.1 mm	IBI-52-55MGRT	.630	16.002	.079	.315	2.007	8.001	545	2.42	730	3.25
3/16" (4.8 mm) D1 = 3/16" 4.8 mm D2 = .375" 9.5 mm k = .060" 1.52 mm d = .114" 2.9 mm P = ≥ 1.063" 27.0 mm .193" 4.9 mm	IBI-62-64MGRT	.540	13.716	.060	.250	1.524	6.350	900	4.00	1010	449
IBI-62-65MGRT	.670	17.018	.060	.354	1.524	8.992					
IBI-64-68MGRT	.790	20.066	.250	.500	6.350	12.700					



MULTI-GRIP BLIND RIVETS - MULTI

DOME HEAD

JBJ-MGRT-SERIES - MULTI-RT

Body: **AISI 316 STAINLESS STEEL**
Mandrel: **AISI 316 STAINLESS STEEL**

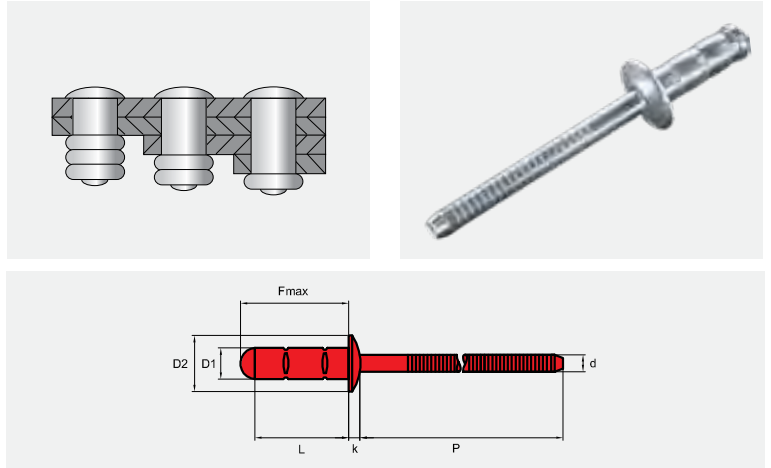

DESCRIPTION ITEM-CODE	F-MAX		GRIP RANGE				SHEAR		TENSILE		
	in	mm	in		mm		lbf	kn	lbf	kn	
			min	max	min	max					
1/8" (3.2 mm) D1 = 1/8" 3.2 mm D2 = .250" 6.35 mm k = .040" 1.0 mm d = .076" 1.9 mm P = ≥ 1.063" 27.0 mm  .13" 3.3 mm	JBJ-41-43MGRT	.570	14.478	.039	.236	0.991	5.994	325	1.45	445	1.98
5/32" (4.0 mm) D1 = 5/32" 4.0 mm D2 = .315" 8.0 mm k = .050" 1.27 mm d = .095" 2.4 mm P = ≥ 1.063" 27.0 mm  .161" 4.1 mm	JBJ-52-55MGRT	.630	16.002	.079	.315	2.007	8.001	545	2.42	730	3.25
3/16" (4.8 mm) D1 = 3/16" 4.8 mm D2 = .375" 9.5 mm k = .060" 1.52 mm d = .114" 2.9 mm P = ≥ 1.063" 27.0 mm  .193" 4.9 mm	JBJ-62-64MGRT	.540	13.716	.060	.250	1.524	6.350	900	4.00	1010	4.49
JBJ-62-65MGRT	.670	17.018	.060	.354	1.524	8.992					
JBJ-64-68MGRT	.790	20.066	.250	.500	6.350	12.700					



MULTI-GRIP BLIND RIVETS - MULTI
COUNTERSUNK HEAD
 ACS-MGCT-SERIES - MULTI-CT

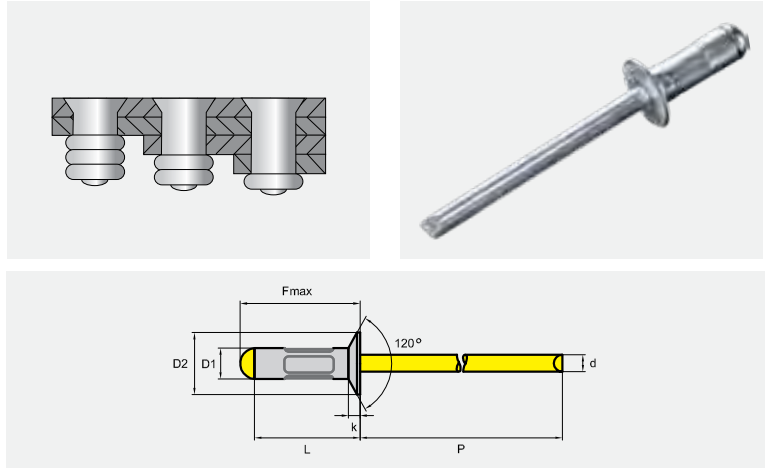

Body: **ALUMINUM**
 Mandrel: **STEEL ZINC PLATED (GALV.)**

DESCRIPTION ITEM-CODE	F-MAX		GRIP RANGE				SHEAR		TENSILE		
	in	mm	in		mm		lbf	kn	lbf	kn	
			min	max	min	max					
1/8" (3.2 mm) D1 = 1/8" 3.2 mm D2 = .220" 5.59 mm k = .040" 1.02 mm d = .076" 1.9 mm P = ≥ 1.063" 27.0 mm .13" 3.3 mm	ACS-42-44MGCT	.480	12.192	.093	.250	2.362	6.350	165	.073	230	1.02
	ACS-42-45MGCT	.530	13.462	.155	.312	3.937	7.925				
	ACS-43-46MGCT	.580	14.732	.217	.375	5.512	9.525				
5/32" (4.0 mm) D1 = 5/32" 4.0 mm D2 = .281" 7.14 mm k = .050" 1.27 mm d = .095" 2.4 mm P = ≥ 1.063" 27.0 mm .161" 4.1 mm	ACS-52-55MGCT	.560	14.224	.109	.312	2.769	7.925	255	1.13	375	1.67
3/16" (4.8 mm) D1 = 3/16" 4.8 mm D2 = .348" 8.84 mm k = .060" 1.52 mm d = .114" 2.9 mm P = ≥ 1.063" 27.0 mm .193" 4.9 mm	ACS-62-65MGCT	.610	15.494	.125	.312	3.175	7.925	345	1.53	525	2.34
	ACS-64-68MGCT	.800	20.320	.250	.500	6.350	12.700				



MULTI-GRIP BLIND RIVETS - MULTI
COUNTERSUNK HEAD
 SCS-MGRT-SERIES - MULTI-RT

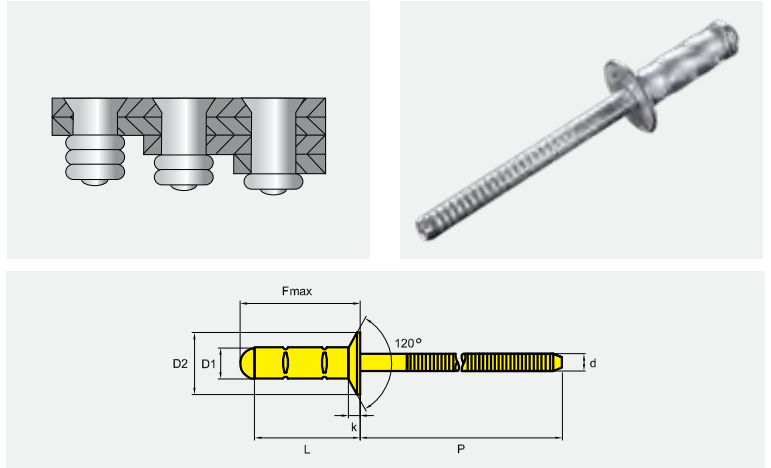

Body: **STEEL ZINC PLATED (GALV.)**
 Mandrel: **STEEL ZINC PLATED (GALV.)**

DESCRIPTION ITEM-CODE	F-MAX		GRIP RANGE				SHEAR		TENSILE		
	in	mm	in		mm		lbf	kn	lbf	kn	
			min	max	min	max					
1/8" (3.2 mm) D1 = 1/8" 3.2 mm D2 = .220" 5.59 mm k = .040" 1.02 mm d = .076" 1.9 mm P = ≥ 1.063" 27.0 mm 	SCS-41-43MGRT	.551	13.995	.039	.236	0.991	5.994	200	0.89	265	1.18
3/16" (4.8 mm) D1 = 3/16" 4.8 mm D2 = .348" 8.84 mm k = .060" 1.52 mm d = .114" 2.9 mm P = ≥ 1.063" 27.0 mm 	SCS-62-64MGRT	.540	13.716	.093	.250	2.362	6.350	540	2.40	650	2.89
SCS-63-66MGRT	.670	17.018	.165	.375	4.191	9.525					
SCS-64-68MGRT	.790	20.066	.250	.500	6.350	12.700					



MULTI-GRIP BLIND RIVETS - MULTI

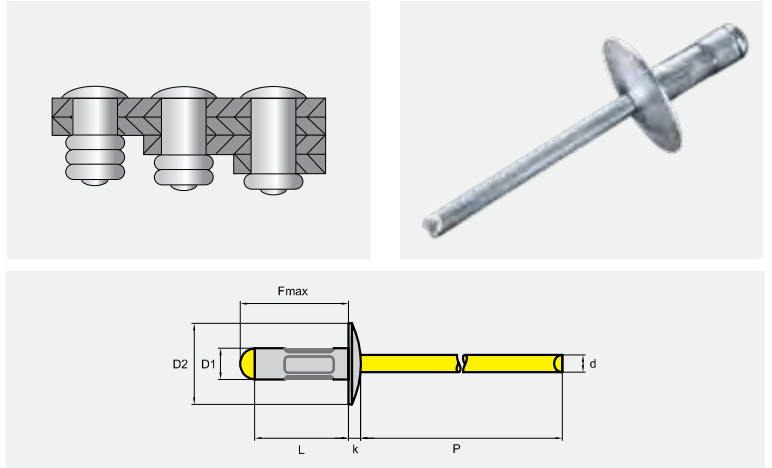

LARGE FLANGE

ABS-MGCT-SERIES - MULTI-CT



Body: **ALUMINUM**

Mandrel: **STEEL ZINC PLATED (GALV.)**

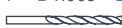
DESCRIPTION ITEM-CODE	F-MAX		GRIP RANGE				SHEAR		TENSILE		
	in	mm	in		mm		lbf	kn	lbf	kn	
			min	max	min	max					
1/8" (3.2 mm) D1 = 1/8" 3.2 mm D2 = .375" 9.5 mm k = .065" 1.65 mm d = .076" 1.9 mm P = ≥ 1.063" 27.0 mm  .13" 3.3 mm	ABS-41-43LFMGCT	.410	10.414	.032	.187	0.813	4.750	165	0.73	230	1.02
	ABS-42-44LFMGCT	.470	11.938	.062	.250	1.575	6.350				
	ABS-43-45LFMGCT	.530	13.462	.125	.312	3.175	7.925				
	ABS-44-46LFMGCT	.590	14.986	.187	.375	4.750	9.525				
5/32" (4.0 mm) D1 = 5/32" 4.0 mm D2 = .470" 11.94 mm k = .075" 1.9 mm d = .095" 2.4 mm P = ≥ 1.063" 27.0 mm  .161" 4.1 mm	ABS-53-55LFMGCT	.550	13.970	.125	.312	3.175	7.925	255	1.13	375	1.67
	ABS-55-58LFMGCT	.770	19.558	.250	.500	6.350	12.700				
3/16" (4.8 mm) D1 = 3/16" 4.8 mm D2 = .625" 15.88 mm k = .092" 2.3 mm d = .114" 2.9 mm P = ≥ 1.063" 27.0 mm  .193" 4.9 mm	ABS-62-64LFMGCT	.550	13.970	.063	.250	1.600	6.350	345	1.53	525	2.34
	ABS-63-67LFMGCT	.740	18.796	.187	.437	4.750	11.100				
	ABS-65-68LFMGCT	.800	20.320	.250	.500	6.350	12.700				
	ABS-69-612LFMGCT	1.110	28.194	.500	.781	12.700	19.837				



MULTI-GRIP BLIND RIVETS - MULTI

LARGE FLANGE

ABI-MGCT-SERIES - MULTI-CT

Body: **ALUMINUM**

Mandrel: **AISI 304 STAINLESS STEEL**

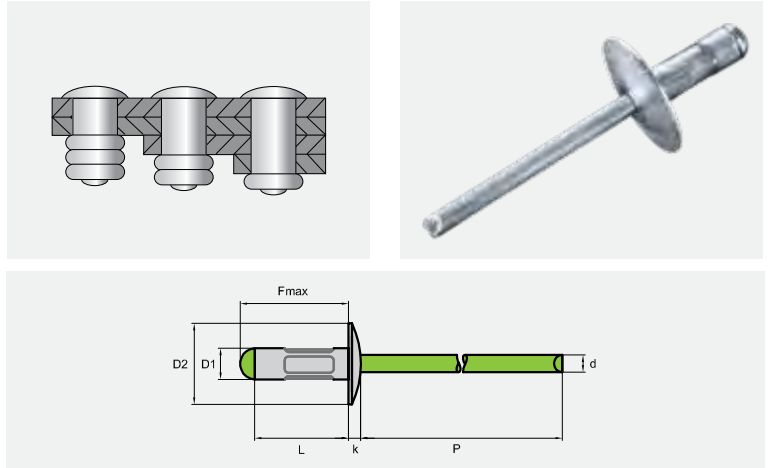

DESCRIPTION ITEM-CODE	F-MAX		GRIP RANGE				SHEAR		TENSILE		
	in	mm	in		mm		lbf	kn	lbf	kn	
			min	max	min	max					
3/16" (4.8 mm) D1 = 3/16" 4.8 mm D2 = .625" 15.88 mm k = .092" 2.3 mm d = .114" 2.9 mm P = ≥ 1.063" 27.0 mm .193" 4.9 mm	ABI-62-64LFMGCT	.534	13.564	.063	.250	1.600	6.350	345	1.53	525	2.34
ABI-65-68LFMGCT	.774	19.660	.250	.500	6.350	12.700					
ABI-69-612LFMGCT	1.086	27.584	.500	.781	12.700	19.837					



MULTI-GRIP BLIND RIVETS - MULTI

LARGE FLANGE

SBS-MGRT-SERIES - MULTI-RT

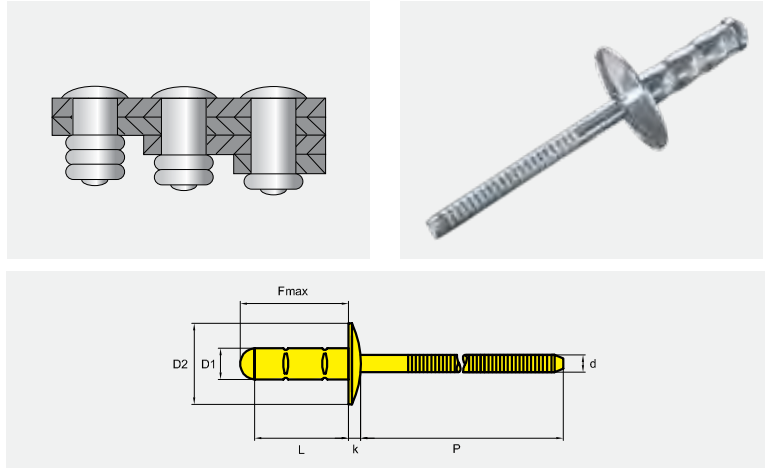

Body: **STEEL ZINC PLATED (GALV.)**
Mandrel: **STEEL ZINC PLATED (GALV.)**

DESCRIPTION ITEM-CODE	F-MAX		GRIP RANGE				SHEAR		TENSILE		
	in	mm	in		mm		lbf	kn	lbf	kn	
			min	max	min	max					
3/16" (4.8 mm) D1 = 3/16" 4.8 mm D2 = .625" 15.88 mm k = .092" 2.3 mm d = .114" 2.9 mm P = ≥ 1.063" 27.0 mm  .193" 4.9 mm	SBS-62-64LFMGRT	.540	13.716	.060	.250	1.524	6.350	540	2.40	645	2.87
SBS-62-65LFMGRT	.670	17.018	.060	.354	1.524	8.992					
SBS-65-68LFMGRT	.790	20.066	.250	.500	6.350	12.700					





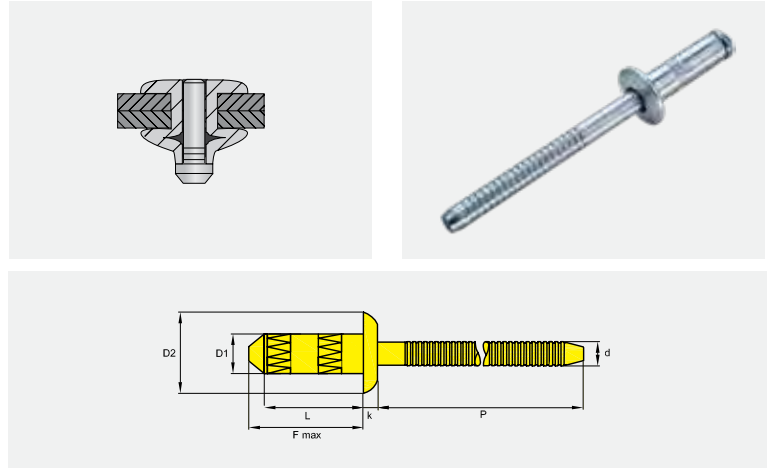

BLIND RIVETS - GO-BULB

DOME HEAD

SBS-GB-SERIES - SEMI-STRUCTURAL BLIND RIVETS



Body: **STEEL ZINC PLATED (GALV.)**
Mandrel: **STEEL ZINC PLATED (GALV.)**

DESCRIPTION ITEM-CODE	F-MAX		GRIP RANGE				SHEAR *		TENSILE *		
	in	mm	in		mm		lbf	kn	lbf	kn	
			min	max	min	max					
1/8" (3.2 mm) D1 = 1/8" 3.2 mm D2 = .268" 6.8 mm k = .055" 1.4 mm d = .080 2.0 mm P = ≥ 1.063" 27.0 mm  .130 - .134" 3.3 - 3.4 mm	SBS-0408-GB	.358	9.093	.039	.118	0.991	2.997	270	1.20	292	1.30
	SBS-0411-GB	.461	11.709	.118	.197	2.997	5.004	393	1.75	292	1.30
	SBS-0414-GB	.551	13.995	.197	.276	5.004	7.010	562	2.50	292	1.30
5/32" (4.0 mm) D1 = 5/32" 4.0 mm D2 = .315" 8.0 mm k = .059" 1.5 mm d = .103" 2.6 mm P = ≥ 1.063" 27.0 mm  .161 - .169" 4.1 - 4.3 mm	SBS-0509-GB	.409	10.389	.039	.118	0.991	2.997	539	2.40	629	2.80
	SBS-0512-GB	.508	12.903	.118	.197	2.997	5.004	787	3.50	629	2.80
	SBS-0516-GB	.618	15.697	.197	.276	5.004	7.010	921	4.10	629	2.80
3/16" (4.8 mm) D1 = 3/16" 4.8 mm D2 = .378" 9.6 mm k = .059" 1.5 mm d = .126" 3.2 mm P = ≥ 1.063" 27.0 mm  .193 - .201" 4.9 - 5.1 mm	SBS-0611-GB	.476	12.090	.059	.138	1.499	3.505	809	3.60	854	3.80
	SBS-0614-GB	.579	14.707	.138	.236	3.505	5.994	944	4.20	854	3.80
	SBS-0618-GB	.693	17.602	.236	.335	5.994	8.509	1258	5.60	854	3.80
.236" (6.0 mm) D1 = .236" 6.0 mm D2 = .484" 12.3 mm k = .083" 2.1 mm d = .158" 4.0 mm P = ≥ 1.26" 32.0 mm  .240 - .248" 6.1 - 6.3 mm	SBS-M6x10-GB	.551	13.995	.059	.157	1.499	3.988	944	4.20	1213	5.40
	SBS-M6x13-GB	.669	16.993	.118	.236	2.997	5.994	1213	5.40	1213	5.40
	SBS-M6x16-GB	.787	19.990	.236	.354	5.994	8.992	1910	8.50	1213	5.40
	SBS-M6x19-GB	.906	23.012	.354	.472	8.992	11.989	1910	8.50	1213	5.40

*Typical values



BLIND RIVETS - GO-INOX

DOME HEAD

IBI-GI-SERIES - SEMI-STRUCTURAL BLIND RIVETS

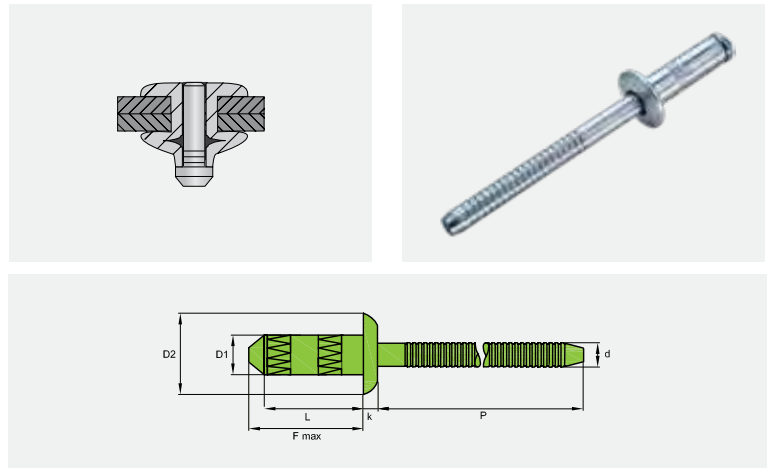

Body: **AISI 304 STAINLESS STEEL**
Mandrel: **AISI 304 STAINLESS STEEL**

DESCRIPTION ITEM-CODE	F-MAX		GRIP RANGE				SHEAR *		TENSILE *		
	in	mm	in		mm		lbf	kn	lbf	kn	
			min	max	min	max					
1/8" (3.2 mm) D1 = 1/8" 3.2 mm D2 = .260" 6.6 mm k = .043" 1.1 mm d = .083 2.1 mm P = ≥ 1.063" 27.0 mm  .130 - .134" 3.3 - 3.4 mm	IBI-0408-GI	.360	9.144	.039	.118	0.991	2.997	360	1.60	450	2.00
	IBI-0411-GI	.460	11.684	.118	.197	2.997	5.004	382	1.70	450	2.00
	IBI-0414-GI	.560	14.224	.197	.276	5.004	7.010	719	3.20	450	2.00
5/32" (4.0 mm) D1 = 5/32" 4.0 mm D2 = .315" 8.0 mm k = .059" 1.5 mm d = .102" 2.6 mm P = ≥ 1.063" 27.0 mm  .161 - .169" 4.1 - 4.3 mm	IBI-0509-GI	.410	10.414	.039	.118	0.991	2.997	629	2.80	899	4.00
	IBI-0512-GI	.510	12.954	.118	.197	2.997	5.004	1169	5.20	899	4.00
	IBI-0516-GI	.620	15.748	.197	.276	5.004	7.010	1169	5.20	899	4.00
3/16" (4.8 mm) D1 = 3/16" 4.8 mm D2 = .378" 9.6 mm k = .059" 1.5 mm d = .126" 3.2 mm P = ≥ 1.063" 27.0 mm  .193 - .201" 4.9 - 5.1 mm	IBI-0611-GI	.510	12.954	.059	.138	1.499	3.505	1236	5.50	1124	5.00
	IBI-0614-GI	.610	15.494	.138	.236	3.505	5.994	1236	5.50	1124	5.00
	IBI-0618-GI	.730	18.542	.236	.335	5.994	8.509	1258	5.60	1124	5.00

* Typical values





BLIND RIVETS - M-LOCK

DOME HEAD

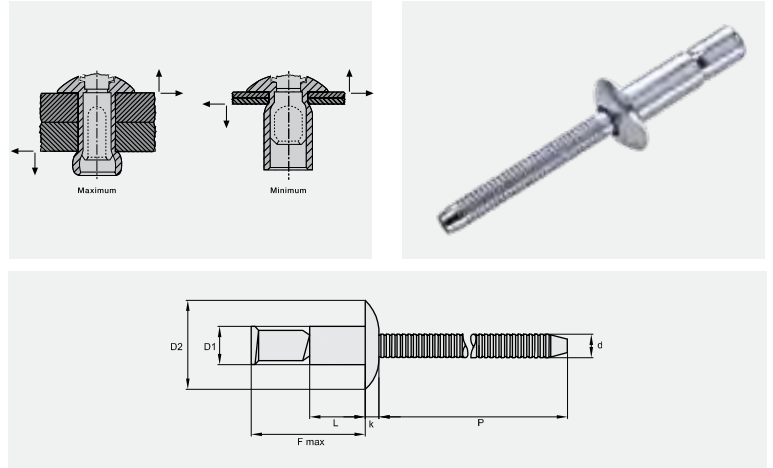
ABA-ML-SERIES - STRUCTURAL BLIND RIVETS



Body: **ALUMINUM**
Mandrel: **ALUMINUM**

DESCRIPTION ITEM-CODE	F-MAX		GRIP RANGE				SHEAR *		TENSILE *		
	in	mm	in		mm		lbf	kn	lbf	kn	
			min	max	min	max					
3/16" (4.8 mm) D1 = 3/16" 4.8 mm D2 = .395" 10.1 mm k = .083" 2.1 mm d = .118" 3.0 mm P = ≥ 1.063" 27.0 mm  .193 - .201" 4.9 - 5.1 mm	ABA-64-ML	.721	18.313	.064	.270	1.626	6.858	675	3.00	500	2.22
	ABA-67-ML	.946	24.028	.064	.437	1.626	11.100	675	3.00	500	2.22
1/4" (6.4 mm) D1 = 1/4" 6.4 mm D2 = .525" 13.4 mm k = .114" 2.9 mm d = .158" 4.0 mm P = ≥ 1.26" 32.0 mm  .260 - .275" 6.6 - 7.0 mm	ABA-86-ML	.965	24.511	.080	.375	2.032	9.525	1350	6.01	950	4.23
	ABA-810-ML	1.366	34.696	.080	.625	2.032	15.875	1350	6.01	950	4.23

* Typical values

Note: For processing of blind rivets "M-LOCK" a special nose piece is required, due to the external mandrel locking feature.





BLIND RIVETS - M-LOCK

DOME HEAD

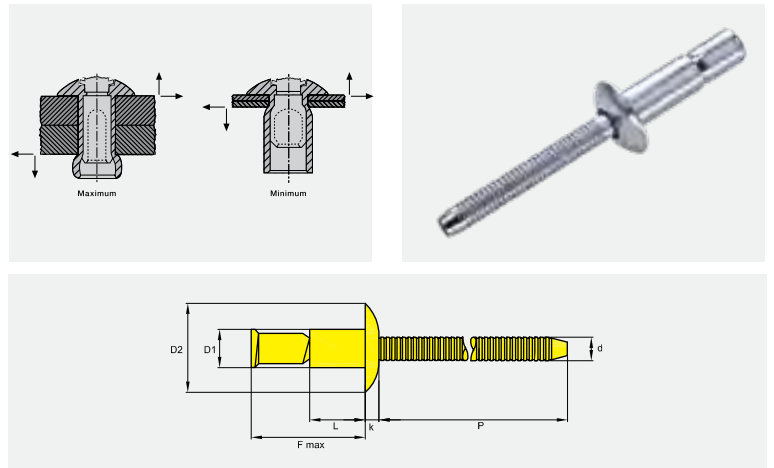
SBS-ML-SERIES - STRUCTURAL BLIND RIVETS



Body: **STEEL ZINC PLATED (GALV.)**
Mandrel: **STEEL ZINC PLATED (GALV.)**

DESCRIPTION ITEM-CODE	F-MAX		GRIP RANGE				SHEAR *		TENSILE *		
	in	mm	in		mm		lbf	kn	lbf	kn	
			min	max	min	max					
3/16" (4.8 mm) D1 = 3/16" 4.8 mm D2 = .395" 10.1 mm k = .083" 2.1 mm d = .118" 3.0 mm P = ≥ 1.063" 27.0 mm  .193 - .201" 4.9 - 5.1 mm	SBS-64-ML	.716	18.186	.064	.270	1.626	6.858	1450	6.45	1150	5.12
	SBS-67-ML	.962	24.435	.064	.437	1.626	11.100	1450	6.45	1150	5.12
1/4" (6.4 mm) D1 = 1/4" 6.4 mm D2 = .525" 13.4 mm k = .114" 2.9 mm d = .158" 4.0 mm P = ≥ 1.26" 32.0 mm  .260 - .275" 6.6 - 7.0 mm	SBS-86-ML	.933	23.698	.080	.375	2.032	9.525	2650	11.79	2350	10.45
	SBS-810-ML	1.296	32.918	.080	.625	2.032	15.875	2650	11.79	2350	10.45

* Typical values

Note: For processing of blind rivets "M-LOCK" a special nose piece is required, due to the external mandrel locking feature.



BLIND RIVETS - M-LOCK

DOME HEAD

IBI-ML-SERIES - STRUCTURAL BLIND RIVETS

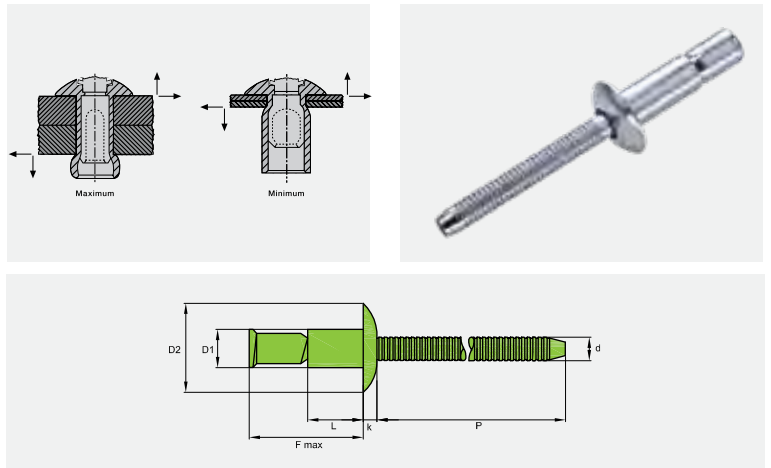

Body: **AISI 304 STAINLESS STEEL**
Mandrel: **AISI 304 STAINLESS STEEL**

DESCRIPTION ITEM-CODE	F-MAX		GRIP RANGE				SHEAR *		TENSILE *	
	in	mm	in		mm		lbf	kn	lbf	kn
			min	max	min	max				
3/16" (4.8 mm)										
IBI-64-ML	.716	18.186	.064	.270	1.626	6.858	1450	6.45	1150	5.12
IBI-67-ML	.962	24.435	.064	.437	1.626	11.100	1450	6.45	1150	5.12
1/4" (6.4 mm)										
IBI-86-ML	.933	23.698	.080	.375	2.032	9.525	2650	11.79	2350	10.45
IBI-810-ML	1.296	32.918	.080	.625	2.032	15.875	2650	11.79	2350	10.45

D1 = 3/16" 4.8 mm
D2 = .395" 10.1 mm
k = .083" 2.1 mm
d = .118" 3.0 mm
P = ≥ 1.063" 27.0 mm
 .193 - .201"
4.9 - 5.1 mm

D1 = 1/4" 6.4 mm
D2 = .525" 13.4 mm
k = .114" 2.9 mm
d = .158" 4.0 mm
P = ≥ 1.26" 32.0 mm
 .260 - .275"
6.6 - 7.0 mm

* Typical values

Note: For processing of blind rivets "M-LOCK" a special nose piece is required, due to the external mandrel locking feature.



BLIND RIVETS - M-LOCK
COUNTERSUNK HEAD 100°

ACA-ML-SERIES - STRUCTURAL BLIND RIVETS

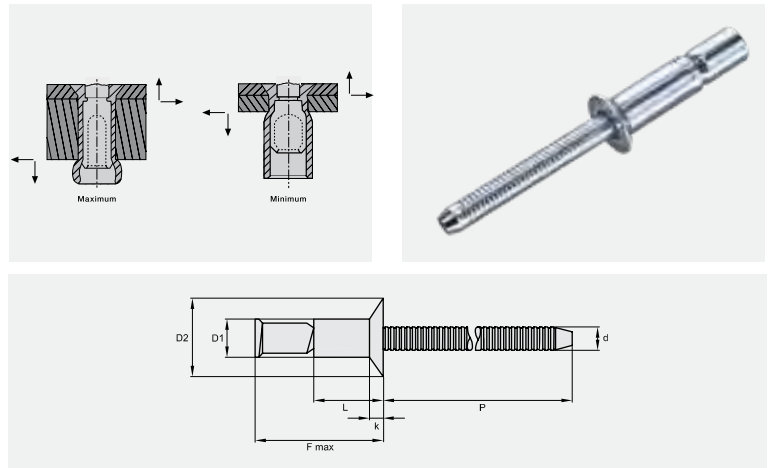

Body: **ALUMINUM**
Mandrel: **ALUMINUM**

DESCRIPTION ITEM-CODE	F-MAX		GRIP RANGE				SHEAR *		TENSILE *	
	in	mm	in		mm		lbf	kn	lbf	kn
			min	max	min	max				
3/16" (4.8 mm)										
ACA-65-ML	.786	19.964	.125	.331	3.175	8.407	675	3.00	500	2.22
ACA-67-ML	1.032	26.213	.125	.481	3.175	12.217	675	3.00	500	2.22

3/16" (4.8 mm)
D1 = 3/16" 4.8 mm
D2 = .325" 8.26 mm
k = .084" 2.1 mm
d = .118" 3.0 mm
P = ≥ 1.063" 27.0 mm
 .193 - .201"
4.9 - 5.1 mm

1/4" (6.4 mm)
D1 = 1/4" 6.4 mm
D2 = .395" 10.03 mm
k = .093" 2.36 mm
d = .158" 4.0 mm
P = ≥ 1.26" 32.0 mm
 .260 - .275"
6.6 - 7.0 mm

* Typical values

Note: For processing of blind rivets "M-LOCK" a special nose piece is required, due to the external mandrel locking feature.



BLIND RIVETS - M-LOCK

COUNTERSUNK HEAD 100°

SCS-ML-SERIES - STRUCTURAL BLIND RIVETS

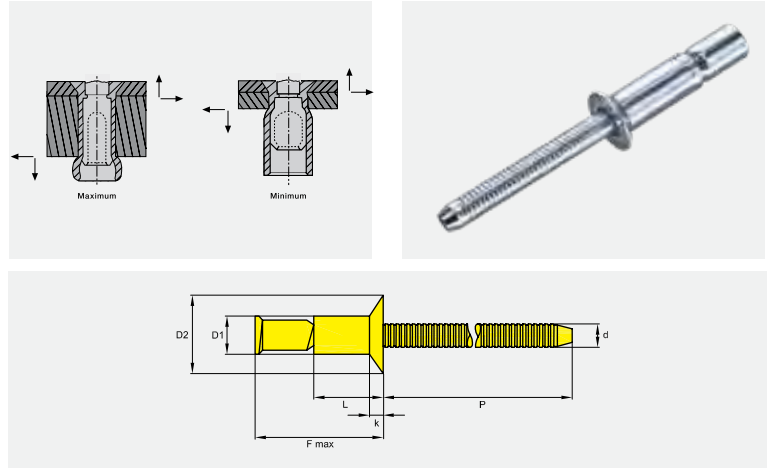

Body: **STEEL ZINC PLATED (GALV.)**
Mandrel: **STEEL ZINC PLATED (GALV.)**

DESCRIPTION ITEM-CODE	F-MAX		GRIP RANGE				SHEAR *		TENSILE *	
	in	mm	in		mm		lbf	kn	lbf	kn
			min	max	min	max				

3/16" (4.8 mm)

D1 = 3/16" 4.8 mm
D2 = .325" 8.26 mm
k = .084" 2.1 mm
d = .118" 3.0 mm
P = ≥ 1.063" 27.0 mm
 .193 - .201"
4.9 - 5.1 mm

SCS-65-ML	.786	19.964	.125	.331	3.175	8.407	1450	6.45	1150	5.12
-----------	------	--------	------	------	-------	-------	------	------	------	------

1/4" (6.4 mm)

D1 = 1/4" 6.4 mm
D2 = .395" 10.03 mm
k = .093" 2.36 mm
d = .158" 4.0 mm
P = ≥ 1.26" 32.0 mm
 .260 - .275"
6.6 - 7.0 mm

SCS-87-ML	1.037	26.340	.125	.475	3.175	12.065	2650	11.79	2350	10.45
-----------	-------	--------	------	------	-------	--------	------	-------	------	-------

* Typical values

Note: For processing of blind rivets "M-LOCK" a special nose piece is required, due to the external mandrel locking feature.

BLIND RIVETS - M-LOCK
COUNTERSUNK HEAD 100°
 ICI-ML-SERIES - STRUCTURAL BLIND RIVETS

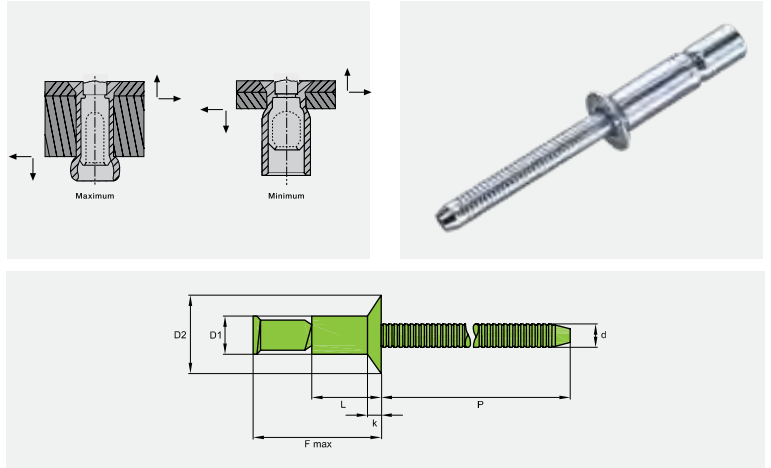

Body: **AISI 304 STAINLESS STEEL**
 Mandrel: **AISI 304 STAINLESS STEEL**

DESCRIPTION ITEM-CODE	F-MAX		GRIP RANGE				SHEAR *		TENSILE *	
	in	mm	in		mm		lbf	kn	lbf	kn
			min	max	min	max				

3/16" (4.8 mm)

D1 = 3/16" 4.8 mm
 D2 = .325" 8.26 mm
 k = .084" 2.1 mm
 d = .118" 3.0 mm
 P = ≥ 1.063" 27.0 mm
 .193 - .201"
 4.9 - 5.1 mm

ICI-65-ML	.786	18.186	.125	.331	3.175	8.407	1450	6.45	1150	5.12
-----------	------	--------	------	------	-------	-------	------	------	------	------

1/4" (6.4 mm)

D1 = 1/4" 6.4 mm
 D2 = .395" 10.03 mm
 k = .093" 2.36 mm
 d = .158" 4.0 mm
 P = ≥ 1.26" 32.0 mm
 .260 - .275"
 6.6 - 7.0 mm

ICI-87-ML	.1037	23.698	.125	.475	3.175	12.065	2650	11.79	2350	10.45
-----------	-------	--------	------	------	-------	--------	------	-------	------	-------

* Typical values

Note: For processing of blind rivets "M-LOCK" a special nose piece is required, due to the external mandrel locking feature.



BLIND RIVETS - GO-LOCK

DOME HEAD

ABA-GL-SERIES - STRUCTURAL BLIND RIVETS

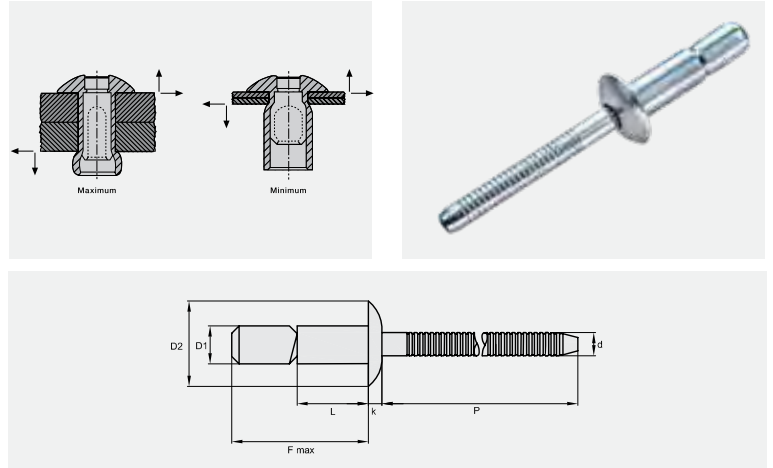

Body: **ALUMINUM**
Mandrel: **ALUMINUM**

DESCRIPTION ITEM-CODE	F-MAX		GRIP RANGE				SHEAR *		TENSILE *	
	in	mm	in		mm		lbf	kn	lbf	kn
			min	max	min	max				
3/16" (4.8 mm)										
ABA-64-GL	.842	21.387	.062	.270	1.575	6.858	600	2.67	450	2.00
ABA-67-GL	.975	24.765	.062	.437	1.575	11.100	600	2.67	450	2.00
1/4" (6.4 mm)										
ABA-86-GL	1.181	29.997	.080	.375	2.032	9.525	1300	5.78	830	3.69
ABA-810-GL	1.400	35.560	.080	.625	2.032	15.875	1300	5.78	830	3.69

D1 = 3/16" 4.8 mm
D2 = .400" 10.1 mm
k = .090" 2.29 mm
d = .118" 3.0 mm
P = ≥ 1.063" 27.0 mm
 .193 - .201"
4.9 - 5.1 mm

D1 = 1/4" 6.4 mm
D2 = .530" 13.46 mm
k = .117" 2.97 mm
d = .158" 4.0 mm
P = ≥ 1.26" 32.0 mm
 .260 - .275"
6.6 - 7.0 mm

* Typical values



BLIND RIVETS - GO-LOCK

DOME HEAD

SBS-GL-SERIES - STRUCTURAL BLIND RIVETS

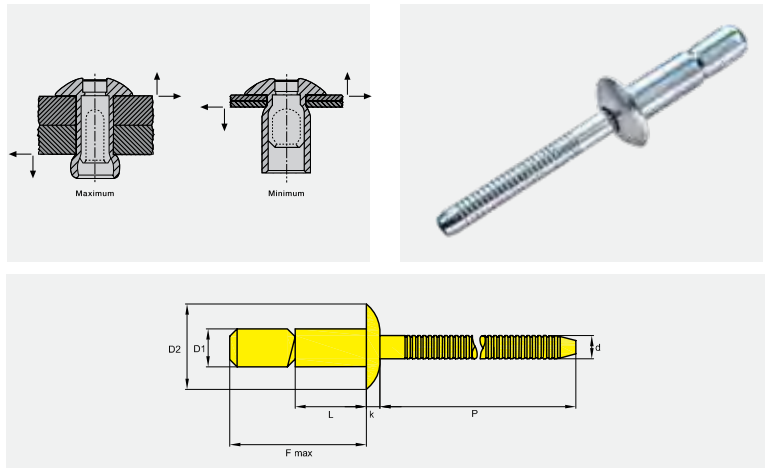

Body: **STEEL ZINC PLATED (GALV.)**
Mandrel: **STEEL ZINC PLATED (GALV.)**

DESCRIPTION ITEM-CODE	F-MAX		GRIP RANGE				SHEAR *		TENSILE *	
	in	mm	in		mm		lbf	kn	lbf	kn
			min	max	min	max				
3/16" (4.8 mm)										
SBS-64-GL	.716	18.186	.062	.270	1.575	6.858	1300	5.78	1000	4.45
SBS-67-GL	1.003	25.476	.062	.437	1.575	11.100	1300	5.78	1000	4.45
1/4" (6.4 mm)										
SBS-86-GL	1.181	29.997	.080	.375	2.032	9.525	2400	10.68	1850	8.23
SBS-810-GL	1.425	36.195	.080	.625	2.032	15.875	2400	10.68	1850	8.23

3/16" (4.8 mm)
D1 = 3/16" 4.8 mm
D2 = .400" 10.1 mm
k = .090" 2.29 mm
d = .118" 3.0 mm
P = ≥ 1.063" 27.0 mm
 .193 - .201"
4.9 - 5.1 mm

1/4" (6.4 mm)
D1 = 1/4" 6.4 mm
D2 = .530" 13.46 mm
k = .117" 2.97 mm
d = .158" 4.0 mm
P = ≥ 1.26" 32.0 mm
 .260 - .275"
6.6 - 7.0 mm

* Typical values





BLIND RIVETS - GO-LOCK

DOME HEAD

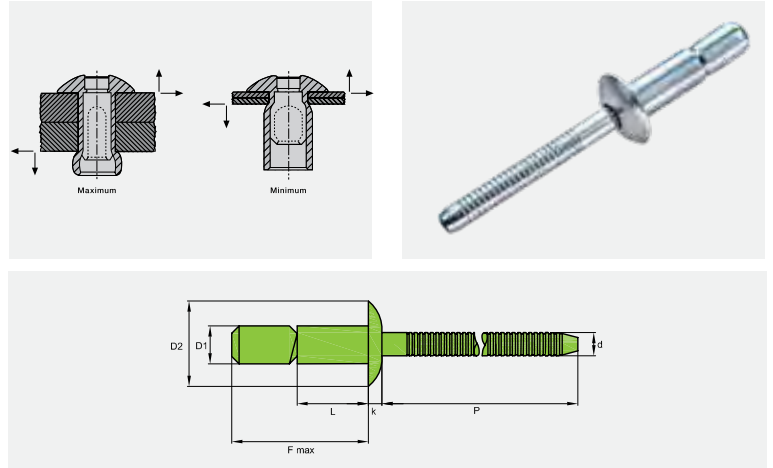
IBI-GL-SERIES - STRUCTURAL BLIND RIVETS



Body: **AISI 304 STAINLESS STEEL**
Mandrel: **AISI 304 STAINLESS STEEL**

DESCRIPTION ITEM-CODE	F-MAX		GRIP RANGE				SHEAR *		TENSILE *		
	in	mm	in		mm		lbf	kn	lbf	kn	
			min	max	min	max					
3/16" (4.8 mm) D1 = 3/16" 4.8 mm D2 = .400" 10.1 mm k = .090" 2.29 mm d = .118" 3.0 mm P = ≥ 1.063" 27.0 mm  .193 - .201" 4.9 - 5.1 mm	IBI-64-GL	.842	21.387	.062	.270	1.575	6.858	1300	5.78	1000	4.45
	IBI-67-GL	1.003	25.476	.062	.437	1.575	11.100	1300	5.78	1000	4.45
1/4" (6.4 mm) D1 = 1/4" 6.4 mm D2 = .530" 13.46 mm k = .117" 2.97 mm d = .158" 4.0 mm P = ≥ 1.26" 32.0 mm  .260 - .275" 6.6 - 7.0 mm	IBI-86-GL	1.119	28.423	.080	.375	2.032	9.525	2400	10.68	1850	8.23
	IBI-810-GL	1.431	36.347	.080	.625	2.032	15.875	2400	10.68	1850	8.23

* Typical values



BLIND RIVETS - GO-LOCK

COUNTERSUNK HEAD 100°

ACA-GL-SERIES - STRUCTURAL BLIND RIVETS

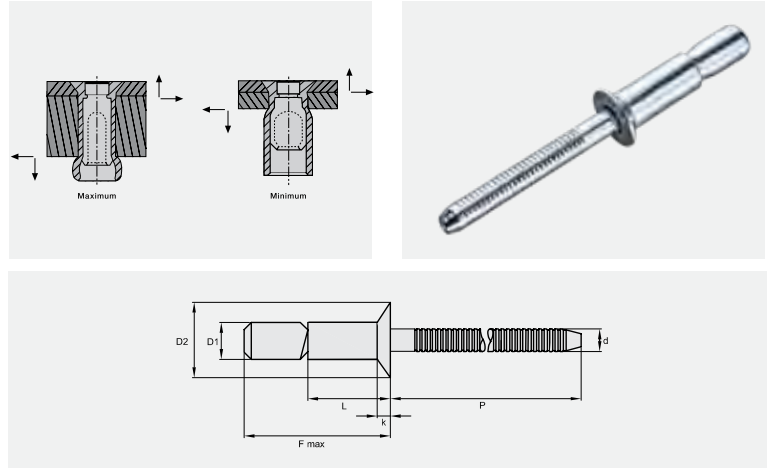

Body: **ALUMINUM**
Mandrel: **ALUMINUM**

DESCRIPTION ITEM-CODE	F-MAX		GRIP RANGE				SHEAR *		TENSILE *	
	in	mm	in		mm		lbf	kn	lbf	kn
			min	max	min	max				
3/16" (4.8 mm)										
ACA-65-GL	.793	20.142	.125	.331	3.175	8.407	550	2.45	450	2.00
ACA-68-GL	1.115	28.321	.303	.500	7.696	12.700	550	2.45	450	2.00

3/16" (4.8 mm)

D1 = 3/16" 4.8 mm

D2 = .345" 8.76 mm

k = .070" 1.78 mm

d = .118" 3.0 mm

P = ≥ 1.063" 27.0 mm

 .193 - .201"
4.9 - 5.1 mm

1/4" (6.4 mm)

D1 = 1/4" 6.4 mm

D2 = .415" 10.54 mm

k = .079" 2.01 mm

d = .158" 4.0 mm

P = ≥ 1.26" 32.0 mm

 .260 - .275"
6.6 - 7.0 mm

ACA-87-GL	1.115	28.321	.170	.475	4.318	12.065	1215	5.40	810	3.60
-----------	-------	--------	------	------	-------	--------	------	------	-----	------

* Typical values



BLIND RIVETS - GO-LOCK

COUNTERSUNK HEAD 100°

SCS-GL-SERIES - STRUCTURAL BLIND RIVETS

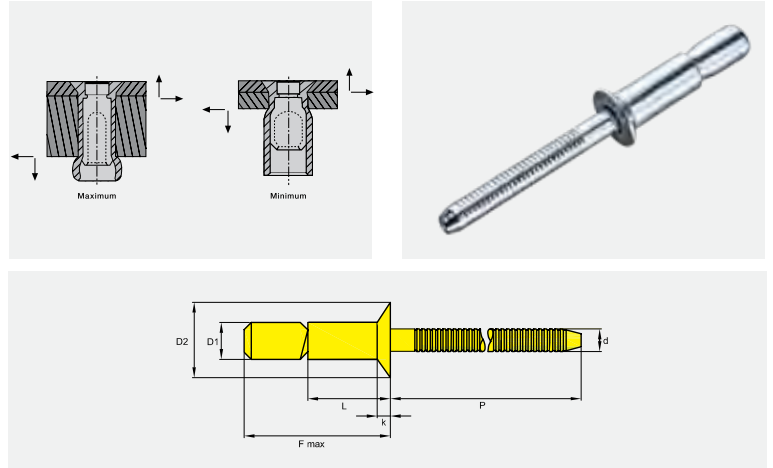

Body: **STEEL ZINC PLATED (GALV.)**
Mandrel: **STEEL ZINC PLATED (GALV.)**

DESCRIPTION ITEM-CODE	F-MAX		GRIP RANGE				SHEAR *		TENSILE *		
	in	mm	in		mm		lbf	kn	lbf	kn	
			min	max	min	max					
3/16" (4.8 mm) D1 = 3/16" 4.8 mm D2 = .345" 8.76 mm k = .070" 1.78 mm d = .118" 3.0 mm P = ≥ 1.063" 27.0 mm ⌀ .193 - .201" 4.9 - 5.1 mm	SCS-65-GL	.793	20.142	.125	.331	3.175	8.407	1300	5.78	1000	4.45
1/4" (6.4 mm) D1 = 1/4" 6.4 mm D2 = .415" 10.54 mm k = .079" 2.01 mm d = .158" 4.0 mm P = ≥ 1.26" 32.0 mm ⌀ .260 - .275" 6.6 - 7.0 mm	SCS-87-GL	1.115	28.321	.170	.475	4.318	12.065	2400	10.68	1850	8.23

* Typical values



BLIND RIVETS - GO-LOCK

COUNTERSUNK HEAD 100°

ICI-GL-SERIES - STRUCTURAL BLIND RIVETS

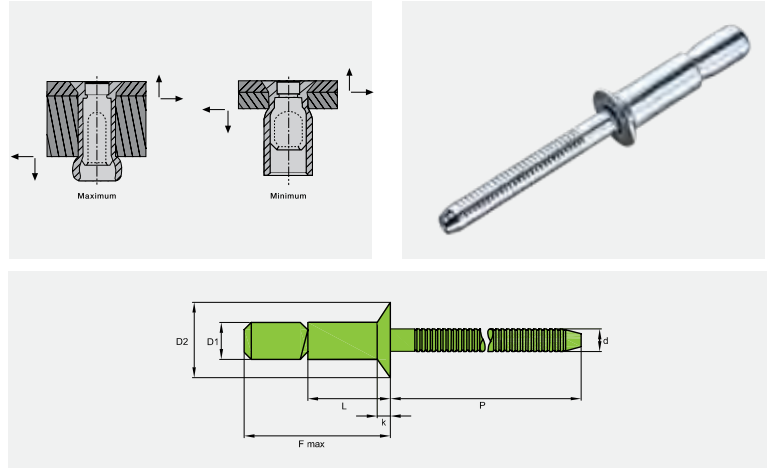

Body: **AISI 304 STAINLESS STEEL**
Mandrel: **AISI 304 STAINLESS STEEL**

DESCRIPTION ITEM-CODE	F-MAX		GRIP RANGE				SHEAR *		TENSILE *	
	in	mm	in		mm		lbf	kn	lbf	kn
			min	max	min	max				
3/16" (4.8 mm)										
ICI-65-GL	.793	20.142	.125	.331	3.175	8.407	1300	5.78	1000	4.45
ICI-68-GL	1.115	28.321	.303	.500	7.696	12.700	1300	5.78	1000	4.45

3/16" (4.8 mm)

D1 = 3/16" 4.8 mm

D2 = .345" 8.76 mm

k = .070" 1.78 mm

d = .118" 3.0 mm

P = ≥ 1.063" 27.0 mm

 .193 - .201"
4.9 - 5.1 mm

1/4" (6.4 mm)

D1 = 1/4" 6.4 mm

D2 = .415" 10.54 mm

k = .079" 2.01 mm

d = .158" 4.0 mm

P = ≥ 1.26" 32.0 mm

 .260 - .275"
6.6 - 7.0 mm

ICI-87-GL	1.115	28.321	.170	.475	4.318	12.065	2400	10.68	1850	8.23
-----------	-------	--------	------	------	-------	--------	------	-------	------	------

* Typical values



BLIND RIVETS - H-LOCK

DOME HEAD

SBS-HL-SERIES - STRUCTURAL BLIND RIVETS

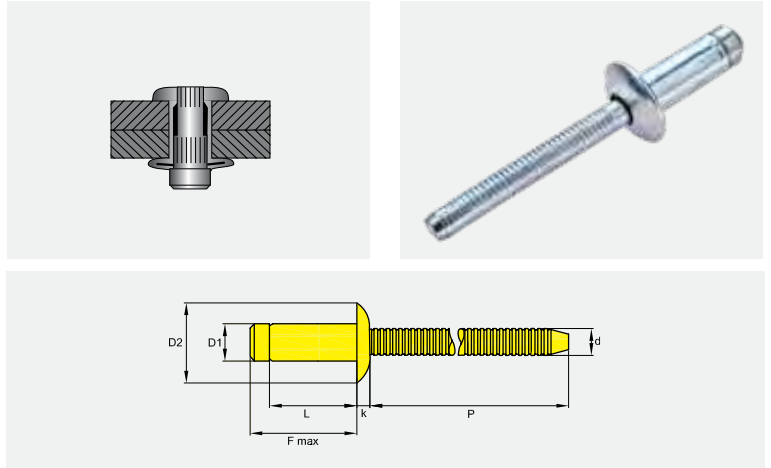

Body: **STEEL ZINC PLATED (GALV.)**
Mandrel: **STEEL ZINC PLATED (GALV.)**

DESCRIPTION ITEM-CODE	F-MAX		GRIP RANGE				SHEAR *		TENSILE *		
	in	mm	in		mm		lbf	kn	lbf	kn	
			min	max	min	max					
1/4" (6.4 mm) D1 = 1/4" 6.4 mm D2 = .530" 13.46 mm k = .110" 2.8 mm d = .158" 4.0 mm P = ≥ 1.26" 32.0 mm  .260 - .275" 6.6 - 7.0 mm	SBS-0812-HL	.539	13.691	.060	.138	1.524	3.505	2360	10.50	1978	8.80
	SBS-0813-HL	.590	14.986	.110	.189	2.794	4.801	2698	12.00	1978	8.80
	SBS-0814-HL	.612	15.545	.132	.211	3.353	5.359	2810	12.50	1978	8.80
	SBS-0815-HL	.669	16.993	.189	.268	4.801	6.807	2810	12.50	1978	8.80
	SBS-0817-HL	.747	18.974	.268	.346	6.807	8.788	3147	14.00	1978	8.80
	SBS-0818-HL	.775	19.685	.295	.374	7.493	9.500	3372	15.00	1978	8.80
	SBS-0819-HL	.826	20.980	.346	.425	8.788	10.795	3597	16.00	1978	8.80
	SBS-0821-HL	.905	22.987	.425	.504	10.795	12.802	3597	16.00	1978	8.80

* Typical values





BLIND RIVETS - PREMIUM

DOME HEAD

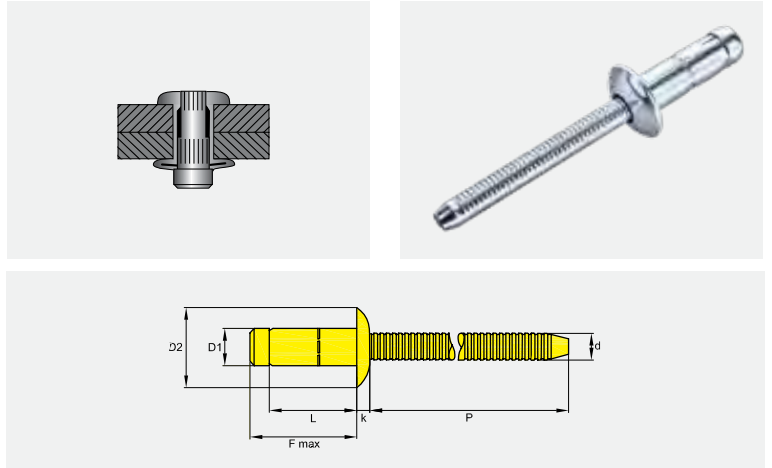
SBS-PM-SERIES - STRUCTURAL BLIND RIVETS



Body: **STEEL ZINC PLATED (GALV.)**
Mandrel: **STEEL ZINC PLATED (GALV.)**

DESCRIPTION ITEM-CODE	F-MAX		GRIP RANGE				SHEAR *		TENSILE *		
	in	mm	in		mm		lbf	kn	lbf	kn	
			min	max	min	max					
3/16" (4.8 mm) D1 = 3/16" 4.8 mm D2 = .386" 9.8 mm k = .087" 2.2 mm d = .119" 3.02 mm P = ≥ 1.181" 30.0 mm  .193 - .201" 4.9 - 5.1 mm	SBS-62-PM	.492	12.497	.059	.138	1.499	3.505	1030	4.58	795	3.54
	SBS-63-PM	.590	14.986	.138	.236	3.505	5.994	1370	6.09	795	3.54
	SBS-65-PM	.689	17.501	.236	.335	5.994	8.509	1430	6.36	795	3.54
	SBS-67-PM	.787	19.990	.335	.433	8.509	10.998	1430	6.36	795	3.54
	SBS-68-PM	.885	22.479	.433	.531	10.998	13.487	1430	6.36	795	3.54
1/4" (6.4 mm) D1 = 1/4" 6.4 mm D2 = .512" 13.0 mm k = .118" 3.0 mm d = .164" 4.17 mm P = ≥ 1.26" 32.0 mm  .256 - .264" 6.5 - 6.7 mm	SBS-82-PM	.532	13.513	.059	.138	1.499	3.505	1570	6.98	1480	6.58
	SBS-83-PM	.590	14.986	.110	.189	2.794	4.801	2100	9.34	1480	6.58
	SBS-84-PM	.670	17.018	.189	.268	4.801	6.807	2330	10.36	1480	6.58
	SBS-85-PM	.748	18.999	.268	.346	6.807	8.788	2560	11.39	1480	6.58
	SBS-87-PM	.826	20.980	.346	.425	8.788	10.795	2560	11.39	1480	6.58
	SBS-88-PM	.905	22.987	.425	.504	10.795	12.802	2560	11.39	1480	6.58
	SBS-89-PM	.984	24.986	.504	.583	12.802	14.808	2560	11.39	1480	6.58
	SBS-810-PM	1.063	27.000	.583	.661	14.808	16.789	2560	11.39	1480	6.58
	SBS-811-PM	1.142	29.007	.661	.740	16.789	18.796	2560	11.39	1480	6.58

* Typical values





BLIND RIVETS - PREMIUM

DOME HEAD

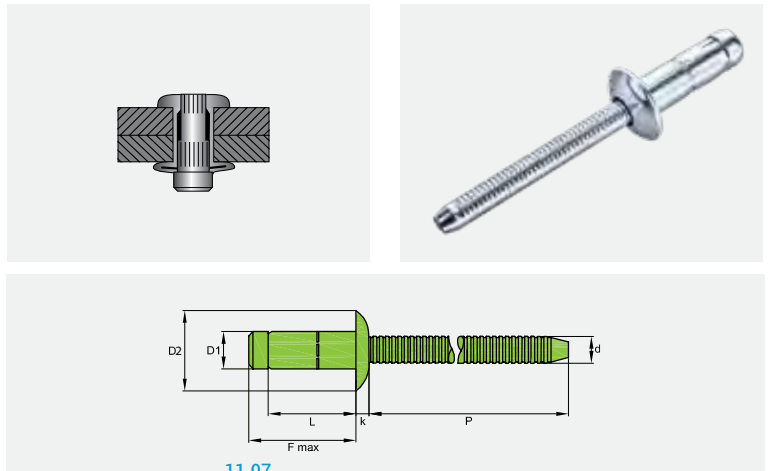
IBI-PM-SERIES - STRUCTURAL BLIND RIVETS



Body: **AISI 304 STAINLESS STEEL**
Mandrel: **AISI 304 STAINLESS STEEL**

DESCRIPTION ITEM-CODE	F-MAX		GRIP RANGE				SHEAR *		TENSILE *		
	in	mm	in		mm		lbf	kn	lbf	kn	
			min	max	min	max					
3/16" (4.8 mm) D1 = 3/16" 4.8 mm D2 = .386" 9.8 mm k = .087" 2.2 mm d = .119" 3.02 mm P = ≥ 1.181" 30.0 mm  .193 - .201" 4.9 - 5.1 mm	IBI-62-PM	.492	12.497	.059	.138	1.499	3.505	1390	6.18	1140	5.07
	IBI-63-PM	.590	14.986	.138	.236	3.505	5.994	1570	6.98	1140	5.07
	IBI-65-PM	.689	17.501	.236	.335	5.994	8.509	1570	6.98	1140	5.07
	IBI-67-PM	.787	19.990	.335	.433	8.509	10.998	1570	6.98	1140	5.07
	IBI-68-PM	.885	22.479	.433	.531	10.998	13.487	1570	6.98	1140	5.07
1/4" (6.4 mm) D1 = 1/4" 6.4 mm D2 = .512" 13.0 mm k = .118" 3.0 mm d = .164" 4.17 mm P = ≥ 1.26" 32.0 mm  .256 - .264" 6.5 - 6.7 mm	IBI-82-PM	.532	13.513	.059	.138	1.499	3.505	1700	7.56	1790	7.96
	IBI-83-PM	.590	14.986	.110	.189	2.794	4.801	2240	9.96	1790	7.96
	IBI-84-PM	.670	17.018	.189	.268	4.801	6.807	2470	10.99	1790	7.96
	IBI-85-PM	.748	18.999	.268	.346	6.807	8.788	2690	11.97	1790	7.96
	IBI-87-PM	.826	20.980	.346	.425	8.788	10.795	2690	11.97	1790	7.96
	IBI-88-PM	.905	22.987	.425	.504	10.795	12.802	2690	11.97	1790	7.96
	IBI-89-PM	.984	24.987	.504	.583	12.802	14.808	2690	11.97	1790	7.96
	IBI-810-PM	1.063	27.000	.583	.661	14.808	16.789	2690	11.97	1790	7.96
	IBI-811-PM	1.142	29.007	.661	.740	16.789	18.796	2690	11.97	1790	7.96

* Typical values



TRIPLE CLAW BLIND RIVETS - TRI-GO

DOME HEAD

ABA-TIG-SERIES

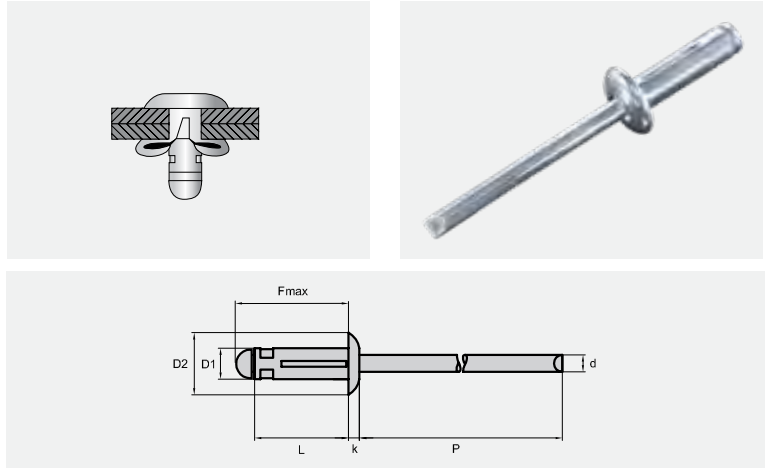

Body: **ALUMINUM**
Mandrel: **ALUMINUM**

DESCRIPTION ITEM-CODE	F-MAX		GRIP RANGE				SHEAR		TENSILE		
	in	mm	in		mm		lbf	kn	lbf	kn	
			min	max	min	max					
5/32" (4.0 mm) D1 = 5/32" 4.0 mm D2 = .315" 8.0 mm k = .060" 1.52 mm d = .095" 2.4 mm P = ≥ 1.063" 27.0 mm ⌀ .165" 4.2 mm	ABA-0516-TIG	.630	16.002	.040	.118	1.016	2.997	135	0.60	225	1.00
ABA-0523-TIG	.840	21.336	.040	.275	1.016	6.985					
ABA-0530TIG	1.087	27.610	.197	.472	5.004	11.989					
3/16" (4.8 mm) D1 = 3/16" 4.8 mm D2 = .386" 9.8 mm k = .071" 1.8 mm d = .114" 2.9 mm P = ≥ 1.063" 27.0 mm ⌀ .196" 5.0 mm	ABA-0619-TIG	.720	18.288	.040	.157	1.016	3.988	175	0.78	240	1.07
ABA-0625-TIG	.920	23.368	.040	.354	1.016	8.992					
ABA-0630-TIG	1.070	27.178	.157	.472	3.988	11.989					



TRIPLE CLAW BLIND RIVETS - TRE-GO

DOME HEAD

ABA-TEG-SERIES

Body: **ALUMINUM**
Mandrel: **ALUMINUM**
Washer: **EPDM**

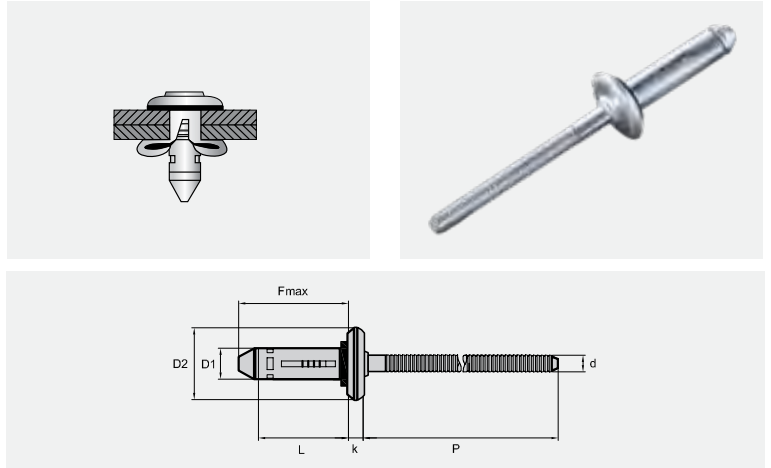

DESCRIPTION ITEM-CODE	F-MAX		GRIP RANGE				SHEAR *		TENSILE *		
	in	mm	in		mm		lbf	kn	lbf	kn	
			min	max	min	max					
3/16" (4.8 mm) D1 = .195 - .205" 4.95 - 5.02 mm D2 = .440" 11.2 mm k = .083" 2.1 mm d = .114" 2.9 mm P = ≥ 1.0" 25.4 mm  .209 - .221" 5.3 - 5.5 mm	ABA-63-TEG	.844	21.438	.050	.187	1.270	4.750	740	3.29	460	2.05
	ABA-64-TEG	.907	23.038	.062	.250	1.575	6.350				
	ABA-66-TEG	1.032	26.213	.188	.375	4.775	9.525				
	ABA-68-TEG	1.157	29.388	.312	.500	7.925	12.700				
	ABA-610-TEG	1.282	32.563	.437	.625	11.100	15.875				
	ABA-612-TEG	1.407	35.738	.563	.750	14.300	19.050				
1/4" (6.4 mm) D1 = .244 - .252" 6.2 - 6.4 mm D2 = .567" 14.4 mm k = .158" 4.0 mm d = .154" 3.9 mm P = ≥ 1.0" 25.4 mm  .252 - .260" 6.4 - 6.6 mm	ABA-84-TEG	.972	24.700	.063	.252	1.600	6.400	850	3.78	506	2.25
	ABA-86-TEG	1.098	27.900	.126	.374	3.200	9.500				
	ABA-88-TEG	1.220	31.000	.252	.500	6.400	12.700				
	ABA-810-TEG	1.346	34.200	.374	.626	9.500	15.900				
9/32" (7.5 mm) D1 = .291 - .307" 7.4 - 7.8 mm D2 = .732" 18.6 mm k = .209" 5.3 mm d = .169" 4.3 mm P = ≥ 1.0" 25.4 mm  .307 - .323" 7.8 - 8.2 mm	ABA-96-TEG	1.268	32.200	.043	.374	1.100	9.500	1237	5.50	990	4.40
	ABA-910-TEG	1.504	38.200	.252	.626	6.400	15.900				
	ABA-912-TEG	1.622	41.200	.374	.752	9.100	19.100				

* Typical values

Note: For processing of blind rivets "TRE-GO" a special nose piece is required, due to the mandrel locking feature.



GROOVED BLIND RIVETS - RILLI

DOME HEAD

ABS-GR-SERIES - GROOVED RIVETS

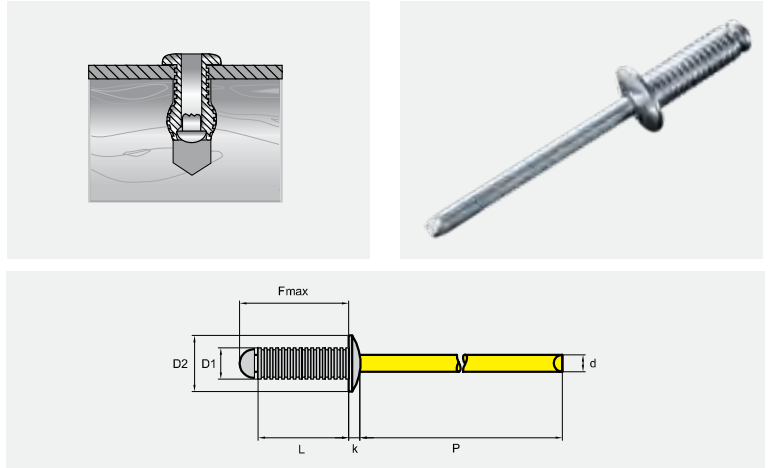

Body: **ALUMINUM**

Mandrel: **STEEL ZINC PLATED (GALV.)**

DESCRIPTION ITEM-CODE	BODY LENGTH ref.		GRIP RANGE				SHEAR		TENSILE		
	in	mm	in		mm		lbf	kn	lbf	kn	
			min	max	min	max					
1/8" (3.2 mm) D1 = 1/8" 3.2 mm D2 = .256" 6.5 mm k = .031" 0.79 mm d = .071" 1.8 mm P = ≥ 1.063" 27.0 mm .136" 3.45 mm	ABS-43-GR	.394	10.008		.236		5.994	135	0.60	180	0.80
	ABS-46-GR	.551	13.995		.394		10.008				
5/32" (4.0 mm) D1 = 5/32" 4.0 mm D2 = .315" 8.0 mm k = .039" 1.0 mm d = .087" 2.2 mm P = ≥ 1.063" 27.0 mm .171" 4.35 mm	ABS-52-GR	.315	8.001		.157		3.988	200	0.89	315	1.40
	ABS-53-GR	.472	11.989		.236		5.994				
	ABS-55-GR	.630	16.002		.315		8.001				
3/16" (4.8 mm) D1 = 3/16" 4.8 mm D2 = .375" 9.5 mm k = .043" 1.0 mm d = .108" 2.74 mm P = ≥ 1.063" 27.0 mm .203" 5.15 mm	ABS-62-GR	.315	8.001		.157		3.988	360	1.60	585	2.60
	ABS-63-GR	.394	10.008		.236		5.994				
	ABS-65-GR	.472	11.989		.315		8.001				
	ABS-66-GR	.551	13.995		.394		10.008				
	ABS-68-GR	.709	18.009		.512		13.005				
	ABS-69-GR	.827	21.006		.591		15.011				
	ABS-612-GR	.945	24.003		.787		19.990				



PEEL BLIND RIVETS - STAR

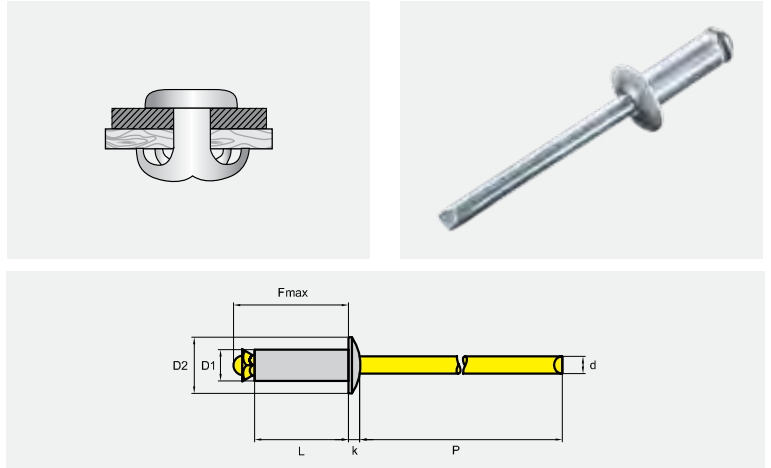

DOME HEAD

ABS-PR-SERIES - PEEL RIVETS



Body: **ALUMINUM**

Mandrel: **STEEL ZINC PLATED (GALV.)**

DESCRIPTION ITEM-CODE	BODY LENGTH ref.		GRIP RANGE				SHEAR		TENSILE		
	in	mm	in		mm		lbf	kn	lbf	kn	
			min	max	min	max					
1/8" (3.2 mm) D1 = 1/8" 3.2 mm D2 = .236" 6.0 mm k = .035" 0.89 mm d = .076" 1.9 mm P = ≥ 1.063" 27.0 mm  .138 - .146" 3.5 - 3.7 mm	ABS-42-PR	.394	10.008	.039	.118	0.991	2.997	175	0.78	160	0.71
	ABS-43-PR	.472	11.989	.119	.197	3.023	5.004				
	ABS-44-PR	.551	13.995	.198	.275	5.029	6.985				
	ABS-45-PR	.630	16.002	.276	.354	7.010	8.992				
5/32" (4.0 mm) D1 = 5/32" 4.0 mm D2 = .315" 8.0 mm k = .051" 1.3 mm d = .095" 2.4 mm P = ≥ 1.063" 27.0 mm  .169 - .177" 4.3 - 4.5 mm	ABS-53-PR	.394	10.008	.059	.197	1.499	5.004	285	1.27	260	1.16
	ABS-54-PR	.472	11.989	.157	.255	3.988	6.477				
	ABS-55-PR	.551	13.995	.236	.354	5.994	8.992				
	ABS-57-PR	.630	16.002	.315	.433	8.001	10.998				
	ABS-58-PR	.709	18.009	.394	.512	10.008	13.005				
	ABS-59-PR	.787	19.990	.472	.590	11.989	14.986				
	ABS-512-PR	.984	24.994	.591	.787	15.011	19.990				
3/16" (4.8 mm) D1 = 3/16" 4.8 mm D2 = .375" 9.5 mm k = .059" 1.5 mm d = .108" 2.74 mm P = ≥ 1.063" 27.0 mm  .201 - .209" 5.3 - 5.3 mm	ABS-62-PR	.394	10.008	.020	.157	0.508	3.988	540	2.40	495	2.20
	ABS-65-PR	.551	13.995	.158	.315	4.013	8.001				
	ABS-67-PR	.709	18.009	.316	.472	8.026	11.989				
	ABS-610-PR	.866	21.996	.473	.630	12.014	16.002				
	ABS-612-PR	.984	24.994	.631	.748	16.027	19.000				
	ABS-615-PR	1.181	29.997	.749	.944	19.024	23.978				
	ABS-618-PR	1.378	35.001	.945	1.141	24.003	28.981				
	ABS-621-PR	1.575	40.005	1.142	1.338	29.007	33.985				
	ABS-624-PR	1.772	45.009	1.339	1.535	34.011	38.989				
	ABS-627-PR	1.968	49.987	1.536	1.732	39.014	43.993				

Note: After Setting the mandrel head might remain within the rivet body or might drop out.



TOOL SELECTION GUIDE



			BLIND RIVETS					
			STANDARD BLIND RIVETS, MULTI-GRIP, TRI-FOLDING, SPECIAL BLIND RIVETS					
			3/32" 2.4 mm	1/8" 3.2 mm	5/32" 4.0 mm	3/16" 4.8 mm	1/4" 6.4 mm	9/32" 7.5mm
HAND	GO-2							
	GO-3							
	GO-55				AS			
	GO-360			AS	AS			
	GO-40							
	GO-25-SN							
	GO-39							
	GO-12-R							
PNEUMATIC HYDRAULIC	AIRPOWER 1							
	AIRPOWER 2							
	AIRPOWER 3							
CORDLESS	GO-100							
	GO-100+					*	*	
	GO-200							

A: ALUMINUM / COPPER
S: STEEL
I: INOX

BLUE FIELD: RECOMMENDED WORKING RANGE (ASI)
EXCEPTIONS ARE INDICATED BY RELEVANT LETTERS
* = SPECIAL NOSE PIECE REQUIRED FOR SETTING



TOOL SELECTION GUIDE

			SEMI-STRUCTURAL BLIND RIVETS						
			GO-BULB II				GO-INOX II		
			1/8" 3.2 mm	5/32" 4.0 mm	3/16" 4.8 mm	.236" 6.0 mm	1/8" 3.2 mm	5/32" 4.0 mm	3/16" 4.8 mm
HAND	GO-40								
	GO-25-SN								
	GO-39								
PNEUMATIC HYDRAULIC	AIRPOWER 1								
	AIRPOWER 2								
	AIRPOWER 3								
CORDLESS	GO-100								
	GO-200								

			STRUCTURAL BLIND RIVETS						
			GO-LOCK		M-LOCK		H-LOCK	PREMIUM	
			3/16" 4.8 mm	1/4" 6.4 mm	3/16" 4.8 mm	1/4" 6.4 mm	1/4" 6.4 mm	3/16" 4.8 mm	1/4" 6.4 mm
HAND	GO-40			AS	*	* AS	AS		AS
	GO-25-N			AS	*	* AS	AS		AS
	GO-39				*	*			
PNEUMATIC HYDRAULIC	AIRPOWER 1		A					A	
	AIRPOWER 2			A					A
	AIRPOWER 3				*	*			
CORDLESS	GO-100			A					A
	GO-200				*	*			

A: ALUMINUM / COPPER
S: STEEL
I: INOX

BLUE FIELD: RECOMMENDED WORKING RANGE (ASI)
EXCEPTIONS ARE INDICATED BY RELEVANT LETTERS
* = SPECIAL NOSE PIECE REQUIRED FOR SETTING



GO-2 - HAND RIVET TOOL

AUTOMATIC EJECTION OF RETAINED MANDREL AFTER SETTING BLIND RIVET

RIVETING CAPACITY FOR BLIND RIVETS

Ø 3/32" up to 3/16"
Ø 2.4 up to 4.8 mm

All Materials



GO-40 - HEAVY DUTY LEVER TYPE HAND RIVET TOOL

HIGH LEVERAGE DESIGN TO REDUCE GRIP FORCE PRESSURE - INCLUDES SPENT MANDREL CONTAINER

RIVETING CAPACITY FOR BLIND RIVETS

Ø 1/8" up to 1/4"
Ø 3.2 up to 6.4 mm

All Materials

FOR STRUCTURAL BLIND RIVETS

Ø 3/16"
Ø 4.8 mm

All Materials

Ø .236", 1/4"
Ø 6.0, 6.4 mm

Aluminum / Steel



GO-100 - LITHIUM-ION CORDLESS RIVET TOOL

RIVETING CAPACITY FOR BLIND RIVETS

Ø 3/32" up to 3/16"
Ø 2.4 up to 4.8 mm

All Materials



AIRPOWER 1 - PNEUMATIC/HYDRAULIC BLIND RIVET SETTING TOOL

RIVETING CAPACITY FOR BLIND RIVETS

Ø 3/32" up to 3/16"
Ø 2.4 up to 4.8 mm

All Materials



RIVET TOOLS FROM GOEBEL FASTENERS

See The Full Tools-Video on Our Website: goebelfasteners.com/media-library