

TABLE OF CONTENTS

SECTION	PAGE	SECTION	PAGE
Drop Forged Turnbuckles		Drop Forged Heavy Duty Eye Nuts	27
Body Only / Body & Stubs	4	Drop Forged Pad Eyes	28
Eye & Eye / Hook & Hook	5	Drop Forged Blank Rod Ends	28
Hook & Eye	6	Black Oxide Machined Rod Ends	29
Jaw & Eye / Jaw & Jaw / Rod End Eye & Eye ...	7	Drop Forged Yoke Ends	30
Midget	8	Clevis Pins – Heat Treated & SAE	30, 31
Drop Forged Shackles		Malleable Bevel Washers / Zinc Plated S-hooks ...	31
Anchor – Round Pin, Screw Pin, Bolt Type	9	Round Bend U-bolts	
Chain – Round Pin, Screw Pin, Bolt Type	10	Zinc Plated	32
Wire Rope Clips		Hot Galvanized	32
Drop Forged	11	Aluminium	33
Malleable	12	Long Tangent – Zinc Plated & Hot Galvanized ..	34
Wire Rope Thimbles	13	Square Bend U-Bolts – Zinc Plated/Hot Galvanized ...	34
Drop Forged Eye Bolts		Zinc Plated Turned Eye Bolts	
Regular – Machine Thread	14	Machine Thread	35
Shoulder – Machine Thread	15	Lag Threads / Welded – Machine Threads ...	36
Regular & Shoulder – Screw Thread	17	Continuous Threaded Rod	
Drop Forged Ring Bolts		Steel-Oil Finish	37
Regular & Shoulder – Machine Thread	16	Zinc Plated Steel	37
Regular & Shoulder – Screw Thread	17	Hot Galvanized / B7-Alloy / Coupling Nuts ...	38
Machinery Eye Bolts		304 Stainless Steel	41
Standard Shank Lengths – Specifications ...	18	Zinc Plated Steel “Shapes”	
Standard Shank Lengths – Plain & Shoulder ...	19	Square Key / Slotted Angles / Slotted Flats ...	39
Zinc Plated / Hot Galvanized – Plain & Shoulder ..	20	Rounds / Flats / Angles	38, 39
Special Shank Lengths – Plain & Shoulder ...	21	Stainless Steel Section	
Metric	22	Drop Forged Blank Rod Ends	40
Drop Forged Lifting Eyes	23	Thimbles / Eye Bolts / Wire Rope Clips	41
Alloy Steel Hoist Rings	23	Machinery Eye Bolts / Regular Drop Forged	
Drop Forged Hooks		Heavy Duty Drop Forged Eye Nuts	42
Eye Hoist, Eye Hoist with Latch	24	Turned Eye Bolts – Machine / S-Hooks	43
High-Test Chain / Safety Snap	24	Round Bend U-Bolts	44
Swivel Hook	25	Round Bend U-Bolts Long Tangent /	
Drop Forged Swivels	25	Square Bend U-Bolts	45
Drop Forged Eye Nuts	26	Formed or Forged Fittings Schematics	46
		Index	47



DROP FORGED TURNBUCKLES



(Class 3)



(Class 2)

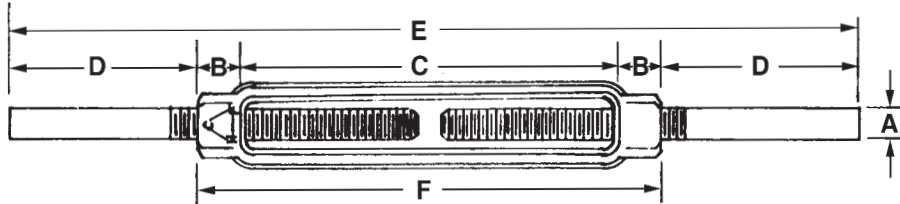

Turnbuckles meet the performance requirements of Federal Specifications F1145 and ASTM FF-T-791B, Type 1 Form 1

Diameter & Take-up Dimensions A x C	Body Only						Body and Stubs				Working Load Limit in Lbs.	
	Drilled & Tapped		Overall Length (F)	Weight per 100 D&T	Blanks		SC Part No.	Dimensions - Inches				Weight per 100
	SC Part No.	Galv. Part No.			SC Part No.	Galv. Part No.		B	D	E		
1/4" x 4"	03805 8	03955 0	4-13/16"	14	00105 2	00255 4	04105 8	13/32"	2-5/8"	10"	25	500
5/16" x 4-1/2"	03810 2	03960 4	5-9/16"	21.5	00110 6	00260 8	04110 2	1-7/32"	2-25/32"	11"	42.5	800
3/8" x 6"	03815 7	03965 9	7-1/8"	37.5	00115 1	00265 3	04115 7	9/16"	4-7/16"	16"	85	1200
1/2" x 2"	03820 1	03970 3	3-1/2"	34	00120 5	00270 7	04120 1	3/4"	3-1/4"	10-1/4"	84	2200
1/2" x 6"	03823 2	03973 4	7-1/2"	66	00123 6	00273 8	04123 2	3/4"	4-1/4"	16"	142.5	2200
1/2" x 9"	03826 3	03976 5	10-1/2"	84.5	00126 7	00276 9	04126 3	3/4"	4-1/4"	19"	170	2200
1/2" x 12"	03829 4	03979 6	13-1/2"	102	00129 8	00279 0	04129 4	3/4"	4-1/4"	22"	200	2200
5/8" x 6"	03834 8	03984 0	7-7/8"	90.5	00134 2	00284 4	04134 8	15/16"	4-1/16"	16"	212.5	3500
5/8" x 9"	03837 9	03987 1	10-7/8"	131	00137 3	00287 5	04137 9	15/16"	4-1/16"	19"	285	3500
5/8" x 12"	03840 9	03990 1	13-7/8"	172.5	00140 3	00290 5	04140 9	15/16"	4-1/16"	22"	317.5	3500
5/8" x 18"	03843 0	03993 2	20-1/4"	345	00143 4	00293 6	04143 0	15/16"	4-1/16"	28"	577.5	3500
3/4" x 6"	03848 5	03998 7	8-1/4"	129	00148 9	00298 1	04148 5	1-1/8"	4-3/8"	17"	320	5200
3/4" x 9"	03851 5	04001 3	11-1/4"	191	00151 9	00301 8	04151 5	1-1/8"	4-3/8"	20"	412.5	5200
3/4" x 12"	03854 6	04004 4	14-1/4"	243	00154 0	00304 9	04154 6	1-1/8"	4-3/8"	23"	497.5	5200
3/4" x 18"	03857 7	04007 5	20-1/4"	336.5	00157 1	00307 0	04157 7	1-1/8"	4-3/8"	29"	677.5	5200
7/8" x 6"	03862 1	04012 9	8-5/8"	196	00162 5	00312 4	04162 1	1-5/16"	4-11/16"	18"	467.5	7200
7/8" x 12"	03865 2	04015 0	14-5/8"	309.5	00165 6	00315 5	04165 2	1-5/16"	4-11/16"	24"	661	7200
7/8" x 18"	03868 3	04018 1	20-5/8"	583.5	00168 7	00318 6	04168 3	1-5/16"	4-11/16"	30"	1039	7200
1" x 6"	03873 7	04023 5	9"	279	00173 1	00323 0	04173 7	1-1/2"	5"	19"	610	9800
1" x 12"	03876 8	04026 6	15"	383	00176 2	00326 1	04176 8	1-1/2"	5"	25"	920	9800
1" x 18"	03879 9	04029 7	21"	566	00179 3	00329 2	04179 9	1-1/2"	5"	31"	1176.5	9800
1-1/8" x 6"	03884 3	04034 1	9"	228	00184 7	00334 6	04184 3	1-11/16"	4-5/8"	19"	693	11500
1-1/8" x 12"	03887 4	04037 2	15"	467.5	00187 8	00337 7	04187 4	1-11/16"	4-5/8"	25"	1017.5	11500
1-1/4" x 6"	03892 8	04042 6	9-3/4"	449	00192 2	00342 1	04192 8	1-7/8"	5-1/8"	20"	1093	14800
1-3/8" x 6"	03897 3	04047 1	9-3/4"	430	00197 7	00347 6	04197 3	2-3/16"	5-1/2"	20-1/2"	1195	17500
1-1/2" x 6"	03902 4	04052 5	10-3/8"	684	00202 8	00352 0	04202 4	2-3/16"	5-1/2"	20-1/2"	1580	21000

Maximum load ratings are based on a straight vertical lift in a gradually increasing manner. Any deviations as angular lifts, shock loads, modification of the basic part, etc., will result in drastically reduced maximum loads.



DROP FORGED TURNBUCKLES



Turnbuckles meet the performance requirements of Federal Specifications F1145 Type 1 Form 1 and ASTM FF-T-791B.

- Meets or exceeds all requirements of ASME B30.26 including identification, ductility, design factor, proof load and temperature requirements.
- Material traceability available through Product Identification Code (PIC) System

Available with hot galvanized or self-colored finish.



(Class 4)

Diameter & Take-up	Eye and Eye			Hook and Hook			Weight per 100 in Lbs.
	Part No.		Closed Length	Part No.		Closed Length	
	SC	Galv.		SC	Galv.		
1/4" x 4"	01105 1	01255 3	8"	02005 3	02155 5	8-1/2"	35
5/16" x 4-1/2"	01110 5	01260 7	9"	02010 7	02160 9	9-1/2"	47.5
3/8" x 6"	01115 0	01265 2	11-1/2"	02015 2	02165 4	12"	90.6
1/2" x 2"	01120 4	01270 6	8-1/2"	02020 6	02170 8	10"	111
1/2" x 6"	01123 5	01273 7	13"	02023 7	02173 9	14-1/4"	170
1/2" x 9"	01126 6	01276 8	16"	02026 8	02176 0	17-1/4"	202
1/2" x 12"	01129 7	01279 9	19"	02029 9	02179 1	20-1/4"	232.5
5/8" x 6"	01134 1	01284 3	13-1/2"	02034 3	02184 5	14-3/4"	260
5/8" x 9"	01137 2	01287 4	17"	02037 4	02187 6	17-3/4"	320
5/8" x 12"	01140 2	01290 4	20-1/2"	02040 4	02190 6	20-3/4"	392.5
5/8" x 18"	01143 3	01293 5	26-1/2"	02043 5	02193 7	26-3/4"	557
3/4" x 6"	01148 8	01298 0	14-3/4"	02048 0	02198 2	16-3/4"	397.5
3/4" x 9"	01151 8	01301 7	18"	02051 0	02201 9	19-3/4"	512.5
3/4" x 12"	01154 9	01304 8	21-3/4"	02054 1	02204 0	22-3/4"	581
3/4" x 18"	01157 0	01307 9	27-3/4"	02057 2	02207 1	28-3/4"	666
7/8" x 6"	01162 4	01312 3	18"	02062 6	02212 5	19"	650
7/8" x 12"	01165 5	01315 4	22-1/2"	02065 7	02215 6	23-3/4"	787.5
7/8" x 18"	01168 6	01318 5	28-1/2"	02068 8	02218 7	29-3/4"	1212
1" x 6"	01173 0	01323 9	17"	02073 2	02223 1	20"	805
1" x 12"	01176 1	01326 0	25"	02076 3	02226 2	25-1/2"	1077.5
1" x 18"	01179 2	01329 1	31"	02079 4	02229 3	31-1/2"	1386



(Class 5)

To ascertain extended length add amount of take-up to length in closed position. Eye, Jaw and Hook fittings are heat treated.

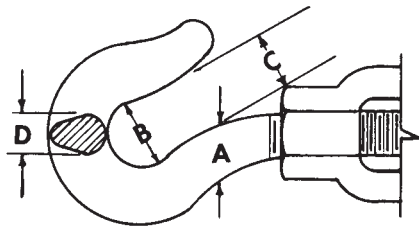

Hook

Dimensions – Inches				Working Load Limit in Lbs.†
A	B	C	D	
1/4"	5/16"	9/32"	7/32"	400
5/16"	1/2"	1/2"	5/16"	700
3/8"	1/2"	1/2"	3/8"	1,000
1/2"	7/8"	13/16"	17/32"	1,500
5/8"	29/32"	27/32"	5/8"	2,250
3/4"	1-1/8"	29/32"	11/16"	3,000
7/8"	1-3/16"	1-1/16"	13/16"	3,200
1"	1-3/8"	1-1/4"	7/8"	5,000

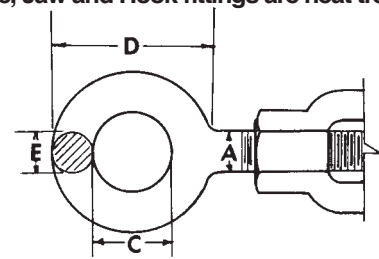

EYE

Dimensions – Inches				Working Load Limit in Lbs.†
A	C	D	E	
1/4"	1/2"	1"	7/32"	500
5/16"	5/8"	1-1/4"	9/32"	800
3/8"	3/4"	1-1/2"	11/32"	1,200
1/2"	1"	2"	7/16"	2,200
5/8"	1-1/4"	2-5/16"	17/32"	3,500
3/4"	1-1/2"	2-3/4"	5/8"	5,200
7/8"	1-3/4"	3-1/2"	7/8"	7,200
1"	2"	3-3/4"	7/8"	10,000

† Loads are based on a design factor of 5 to 1. Maximum load ratings are based on a straight vertical lift in a gradually increasing manner. Any deviations as angular lifts, shock loads, modification of the basic part, etc., will result in drastically reduced maximum loads.



DROP FORGED TURNBUCKLES

Turnbuckles meet the performance requirements of Federal Specifications F1145 Type 1 Form 1 and ASTM FF-T-791B.

- Meets or exceeds all requirements of ASME B30.26 including identification, ductility, design factor, proof load and temperature requirements.
- Material traceability available through Product Identification Code (PIC) System



(Class 6)

Available with hot galvanized or self-colored finish.
Eye, Jaw and Hook fittings are heat treated.

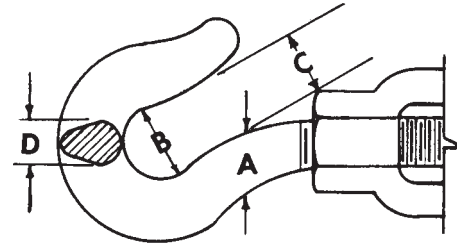

Hook DIMENSIONS – STRENGTH

Dimensions – Inches				Working Load Limit in Lbs.†
A	B	C	D	
1/4"	5/16"	9/32"	7/32"	400
5/16"	1/2"	1/2"	5/16"	700
3/8"	1/2"	1/2"	3/8"	1,000
1/2"	7/8"	13/16"	17/32"	1,500
5/8"	29/32"	27/32"	5/8"	2,250
3/4"	1-1/8"	29/32"	11/16"	3,000
7/8"	1-3/16"	1-1/16"	13/16"	3,200
1"	1-3/8"	1-1/4"	7/8"	5,000

† Loads are based on a design factor of 5 to 1.

Diameter & Take-up	Hook and Eye		Closed Length	Weight per 100 in Lbs.
	Part No. SC	Galv.		
1/4" x 4"	01555 4	01705 3	8-1/4"	35
5/16" x 4-1/2"	01560 8	01710 7	9-1/4"	47.5
3/8" x 6"	01565 3	01715 2	11-3/4"	90.6
1/2" x 2"	01570 7	01720 6	9-1/4"	109
1/2" x 6"	01573 8	01723 7	13-5/8"	170
1/2" x 9"	01576 9	01726 8	16-3/8"	202
1/2" x 12"	01579 0	01729 9	19-5/8"	232.5
5/8" x 6"	01584 4	01734 3	14-1/8"	260
5/8" x 9"	01587 5	01737 4	17-3/8"	320
5/8" x 12"	01590 5	01740 4	20-5/8"	392.5
5/8" x 18"	01593 6	01743 5	26-5/8"	557
3/4" x 6"	01598 1	01748 0	15-3/4"	397.5
3/4" x 9"	01601 8	01751 0	18-7/8"	512.5
3/4" x 12"	01604 9	01754 1	22-1/8"	581
3/4" x 18"	01607 0	01757 2	28-1/8"	666
7/8" x 6"	01612 4	01762 6	18-1/2"	650
7/8" x 12"	01615 5	01765 7	23-1/8"	787.5
7/8" x 18"	01618 6	01768 8	29-1/8"	1212
1" x 6"	01623 0	01773 2	19-1/2"	805
1" x 12"	01626 1	01776 3	25-1/4"	1077.5
1" x 18"	01629 2	01779 4	31-1/4"	1386

To ascertain extended length add amount of take-up to length in closed position.

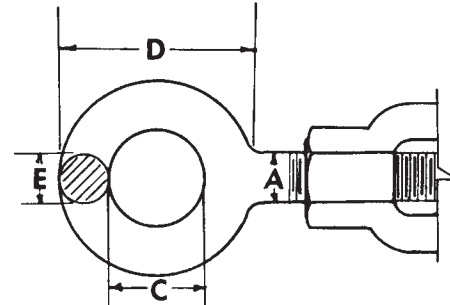

Eye DIMENSIONS – STRENGTH

Dimensions – Inches				Working Load Limit in Lbs.†
A	C	D	E	
1/4"	1/2"	1"	7/32"	500
5/16"	5/8"	1-1/4"	9/32"	800
3/8"	3/4"	1-1/2"	11/32"	1,200
1/2"	1"	2"	7/16"	2,200
5/8"	1-1/4"	2-5/16"	17/32"	3,500
3/4"	1-1/2"	2-3/4"	5/8"	5,200
7/8"	1-3/4"	3-1/2"	7/8"	7,200
1"	2"	3-3/4"	7/8"	10,000

† Loads are based on a design factor of 5 to 1.

Maximum load ratings are based on a straight vertical lift in a gradually increasing manner. Any deviations as angular lifts, shock loads, modification of the basic part, etc., will result in drastically reduced maximum loads.

DROP FORGED TURNBUCKLES



Turnbuckles meet the performance requirements of Federal Specifications F1145 Type 1 Form 1 and ASTM FF-T-791B.

- Meets or exceeds all requirements of ASME B30.26 including identification, ductility, design factor, proof load and temperature requirements.
- Material traceability available through Product Identification Code (PIC) System



Diameter & Take-up	Jaw and Eye Hot Galvanized			Jaw and Jaw Hot Galvanized		
	Part No.	Closed Length	Weight per 100	Part No.	Closed Length	Weight per 100
1/4" x 4"	02605 5	8-1/4"	37.5	03055 7	8-1/2"	40
5/16" x 4-1/2"	02610 9	9-1/8"	52.5	03060 1	9-1/4"	52.5
3/8" x 6"	02615 4	11-1/2"	96.5	03065 6	11-1/2"	97.5
1/2" x 2"	02620 8	8-3/4"	109	03070 0	8-7/8"	119
1/2" x 6"	02623 9	13-1/4"	160	03073 1	13-1/2"	170
1/2" x 9"	02626 0	16-1/4"	198.5	03076 2	16-1/2"	202.5
1/2" x 12"	02629 1	19-1/4"	225	03079 3	19-1/2"	227.5
5/8" x 6"	02634 5	14-5/8"	257.5	03084 7	15-3/4"	260.5
5/8" x 9"	02637 6	17-7/8"	330	03087 8	18-3/4"	330
5/8" x 12"	02640 6	21-1/8"	402	03090 8	21-3/4"	407
5/8" x 18"	02643 7	27-1/8"	581	03093 9	27-3/4"	607
3/4" x 6"	02648 2	15-5/8"	402.5	03098 4	16-1/2"	417.5
3/4" x 9"	02651 2	18-3/4"	522.5	03101 1	19-1/2"	545
3/4" x 12"	02654 3	22"	602.5	03104 2	22-1/2"	619.5
3/4" x 18"	02657 4	28"	702	03107 3	28-1/2"	753
7/8" x 6"	02662 8	19"	655	03112 7	19-1/2"	668
7/8" x 12"	02665 9	23-1/2"	842.5	03115 8	24-1/2"	862.5
7/8" x 18"	02668 0	29-1/2"	1252	03118 9	30-1/2"	1281
1" x 6"	02673 4	19-1/8"	872	03123 3	20-3/16"	911
1" x 12"	02676 5	25-1/4"	1137.5	03126 4	25-1/2"	1165
1" x 18"	02679 6	31-1/4"	1463	03129 5	31-1/2"	1518



(Class 8)



(Class 7)

Available with hot galvanized or self-colored finish. Jaw types supplied with round pins and cotter keys unless nuts and bolts are specified. Locking nuts are also available.

Eye, Jaw and Hook fittings are heat treated.



Diameter & Take-up	Rod End Eye & Eye Self-Colored		
	Part No.	Closed Length	Weight per 100
1/2" x 6"	03373 2	13"	131
5/8" x 6"	03384 8	13-1/4"	205
3/4" x 6"	03398 5	13-1/2"	293
7/8" x 6"	03412 8	14"	456
1" x 6"	03423 4	14-1/8"	589

JAW DIMENSIONS – STRENGTH

Dimensions – Inches								Working Load Limit in Lbs.†
A	B	C	D	*E	F	**H	P	
1/4"	7/32"	5/16"	25/32"	3/8"	5/8"	9/32"	1/4"	500
5/16"	1/4"	5/16"	7/8"	15/32"	5/8"	9/32"	1/4"	800
3/8"	9/32"	13/32"	1"	1/2"	13/16"	11/32"	5/16"	1,200
1/2"	5/16"	1/2"	1-9/32"	5/8"	1"	15/32"	7/16"	2,200
5/8"	3/8"	21/32"	1-21/32"	7/8"	1-5/16"	35/64"	1/2"	3,500
3/4"	1/2"	13/16"	1-27/32"	15/16"	1-5/8"	43/64"	5/8"	5,200
7/8"	9/16"	29/32"	1-31/32"	1-5/32"	1-7/8"	25/32"	3/4"	7,200
1"	11/16"	1-1/16"	2-13/32"	1-3/16"	2"	15/16"	7/8"	10,000

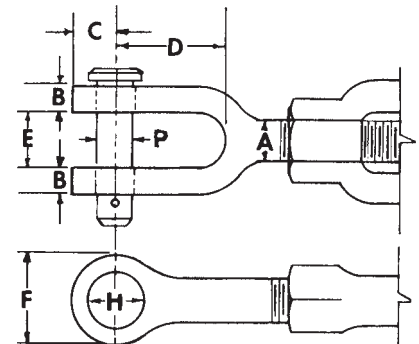

* At parting line: includes 7° draft.

** Hole size.

† Loads are based on a design factor of 5 to 1.



MIDGET TURNBUCKLES

All sizes and types available with sand cast Aluminum bodies, hex heads and zinc plated steel hooks or eyes. Cast malleable iron bodies, zinc plated also available with zinc plated fittings only in sizes denoted. Standard package quantity – 10 pieces. When ordering specify Aluminum or Malleable iron.

EYE & EYE

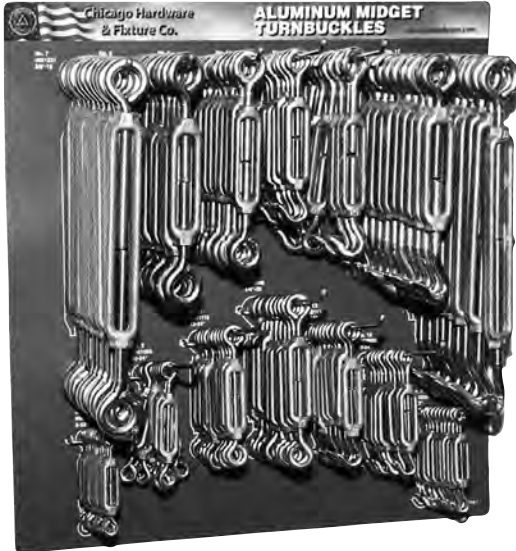

Thread Diameter	Stock No.	Dimensions – Inches Overall Length		Aluminum		Malleable	
		Closed	Open	Part No.	Weight Per 100	Part No.	Weight Per 100
8 - 32	1	3-3/8"	4-5/8"	05105 7	4	05128 6	N.A.
10 - 24	2	4"	5-5/8"	05108 8	6	05131 6	N.A.
12 - 24	3	4-1/2"	6-3/8"	05111 8	8	05134 7	N.A.
1/4" - 20	4	5-1/2"	7-5/8"	05114 9	13	05137 8	13
5/16" - 18	5	6-3/4"	9-1/4"	05117 0	22	05140 8	22
3/8" - 16	6	7-1/2"	10-1/2"	05120 0	38	05143 9	40
3/8" - 16	7	11-3/8"	17-3/8"	05123 1	54	05146 0	N.A.

HOOK & EYE



Thread Diameter	Stock No.	Dimensions – Inches Overall Length		Aluminum		Malleable	
		Closed	Open	Part No.	Weight Per 100	Part No.	Weight Per 100
8 - 32	11	3-3/8"	4-5/8"	05205 4	4	05228 3	N.A.
10 - 24	12	4"	5-5/8"	05208 5	6	05231 3	N.A.
12 - 24	13	4-1/2"	6-3/8"	05211 5	8	05234 4	N.A.
1/4" - 20	14	5-1/2"	7-5/8"	05214 6	13	05237 5	13
5/16" - 18	15	6-3/4"	9-1/4"	05217 7	22	05240 5	22
3/8" - 16	16	7-1/2"	10-1/2"	05220 7	38	05243 6	40
3/8" - 16	17	11-3/8"	17-3/8"	05223 8	54	05246 7	N.A.

HOOK & HOOK



Thread Diameter	Stock No.	Dimensions – Inches Overall Length		Aluminum		Malleable	
		Closed	Open	Part No.	Weight Per 100	Part No.	Weight Per 100
8 - 32	21	3-3/8"	4-5/8"	05305 1	4	05328 0	N.A.
10 - 24	22	4"	5-5/8"	05308 2	6	05331 0	N.A.
12 - 24	23	4-1/2"	6-3/8"	05311 2	8	05334 1	N.A.
1/4" - 20	24	5-1/2"	7-5/8"	05314 3	13	05337 2	13
5/16" - 18	25	6-3/4"	9-1/4"	05317 4	22	05340 2	22
3/8" - 16	26	7-1/2"	10-1/2"	05320 4	38	05343 3	40
3/8" - 16	27	11-3/8"	17-3/8"	05323 5	54	05346 4	N.A.

TURNBUCKLE DISPLAY ALUMINUM ONLY PART # 600101			
QTY	Stock No.	Type	Thread Diameter
10	1	Eye & Eye	8 - 32
10	2	Eye & Eye	10 - 24
10	3	Eye & Eye	12 - 24
10	4	Eye & Eye	1/4" - 20
10	5	Eye & Eye	5/16" - 18
10	6	Eye & Eye	3/8" - 16
10	7	Eye & Eye	3/8" - 16
10	11	Hook & Eye	8 - 32
10	12	Hook & Eye	10 - 24
10	13	Hook & Eye	12 - 24
10	14	Hook & Eye	1/4" - 20
10	15	Hook & Eye	5/16" - 18
10	16	Hook & Eye	3/8" - 16
10	17	Hook & Eye	3/8" - 16
140 Turnbuckles			
Shipping Weight 34 lbs			

Load Ratings	Thread Diameter								
	6-32	8-32	10-24	12-24	1/4"-20	5/16"-18	3/8"-16	7/16"-14	1/2"-13
	Working Load Limit (Pounds)								
Eyebolt (Not Welded)	22	36	38	52	74	96	144	216	298
Turnbuckle Hook	—	36	44	52	68	112	174	—	—
Eyebolt Welded	—	—	—	—	—	240	400	—	1000



DROP FORGED ANCHOR SHACKLES



Size, working load limit, and trademark are permanently marked on all shackles. All shackles and pins are heat treated. Loads are based on a design factor of 6 to 1, except (***) which is 5 to 1. When tested all shackles are pulled at a uniform rate of speed in a direct tension.

- Meets or exceeds all requirements of ASME B30.26 including identification, ductility, design factor, proof load and temperature requirements.
- Material traceability available through Product Identification Code (PIC) System

Shackles Meet Performance Requirements of Federal Specifications RRC-271F Type IVA* Grade A

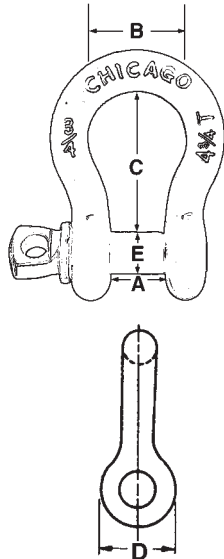

Working Load Limit in Tons	Anchor — Round Pin — Screw Pin — Safety								
	Dimensions - Inches								Estimated Weight Per 100 in lbs.
	Inside						O.D. Eyes (D)	Pin or Bolt Dia. (E)	
	Size Dia.	Width @ Eyes (A)	Tol. ±	Width @ Bow (B)	Length (C)	Tol. ±			
1/3	3/16"	3/8"	1/8"	9/16"	7/8"	1/16"	5/8"	1/4"	
1/2	1/4"	15/32"	1/8"	3/4"	1-1/8"	1/16"	3/4"	5/16"	13.5
3/4	5/16"	17/32"	1/8"	15/16"	1-1/4"	1/16"	7/8"	3/8"	22
1	3/8"	21/32"	1/8"	1-1/8"	1-7/16"	1/8"	1"	7/16"	33
1-1/2	7/16"	23/32"	1/8"	1-5/16"	1-11/16"	1/8"	1-1/8"	1/2"	53.5
2	1/2"	13/16"	1/8"	1-1/2"	1-7/8"	1/8"	1-1/4"	5/8"	76.5
3-1/4	5/8"	1-1/16"	1/8"	1-7/8"	2-3/8"	1/8"	1-11/16"	3/4"	150.5
4-3/4	3/4"	1-1/4"	1/8"	2"	2-13/16"	1/4"	1-7/8"	7/8"	245.5
6-1/2	7/8"	1-7/16"	1/8"	2-5/8"	3-5/16"	1/4"	2-1/8"	1"	375
8-1/2	1"	1-11/16"	1/8"	2-3/4"	3-3/4"	1/4"	2-1/2"	1-1/8"	537.5
9-1/2	1-1/8"	1-13/16"	1/8"	2-15/16"	4-1/4"	1/4"	2-5/8"	1-1/4"	765
12	1-1/4"	2"	1/8"	3-1/4"	4-11/16"	1/4"	3"	1-3/8"	1007.5
13-1/2	***1-3/8"	2-1/4"	3/16"	3-1/2"	5-1/4"	1/4"	3-1/4"	1-1/2"	1232.5
17	1-1/2"	2-3/8"	3/16"	3-3/4"	5-3/4"	1/4"	3-1/2"	1-5/8"	1777.5

All types of shackles are available in a self-colored or hot galvanized finish. When ordering specify the size, finish, and type of shackle. Other rust preventative coatings are available on a special basis.

Bolt type shackles are of the same specifications as the regular types except for the bolt, nut and cotter.

WARNING:

Any deviations such as angular lifts, shock loads, modification of the basic forging, etc., will result in drastically reduced working load limits.

*Class 1

ROUND PIN AND COTTER



*Class 2

SCREW PIN



*Class 3

BOLT, NUT AND COTTER



	Galvanized	Self-Colored
Size	Part No.	Part No.
3/16"	21105 5	21005 8
1/4"	21110 9	21010 2
5/16"	21115 4	21015 7
3/8"	21120 8	21020 1
7/16"	21125 3	21025 6
1/2"	21130 7	21030 0
5/8"	21135 2	21035 5
3/4"	21140 6	21040 9
7/8"	21145 1	21045 4
1"	20150 5	21050 8
1-1/8"	21155 0	21055 3
1-1/4"	21160 4	21060 7
1-3/8"	21165 9	21065 2
1-1/2"	21170 3	21070 6

	Galvanized	Black Oxide	Self-Colored
Size	Part No.	Part No.	Part No.
3/16"	20105 6	20102 5	20005 9
1/4"	20110 0	20104 9	20010 3
5/16"	20115 5	20106 3	20015 8
3/8"	20120 9	20108 7	20020 2
7/16"	20125 4	20112 4	20025 7
1/2"	20130 8	20114 8	20030 1
5/8"	20135 3	20116 2	20035 6
3/4"	20140 7	20118 6	20040 0
7/8"	20145 2	20122 3	20045 5
1"	20150 6	20124 7	20050 9
1-1/8"	20155 1	N.A.	20055 4
1-1/4"	20160 5	N.A.	20060 8
1-3/8"	20165 0	N.A.	20065 3
1-1/2"	20170 4	N.A.	20070 7

	Galvanized	Black Oxide	Self-Colored
Size	Part No.	Part No.	Part No.
1/4"	20610 5	20136 0	20510 8
5/16"	20615 0	20138 4	20515 3
3/8"	20620 4	20142 1	20520 7
7/16"	20625 9	20144 5	20525 2
1/2"	20630 3	20146 9	20530 6
5/8"	20635 8	20148 3	20535 1
3/4"	20640 2	20152 0	20540 5
7/8"	20645 7	20154 4	20545 0
1"	20650 1	20156 8	20550 4
1-1/8"	20655 6	N.A.	20555 9
1-1/4"	20660 0	N.A.	20560 3
1-1/2"	20670 9	N.A.	20570 2





DROP FORGED CHAIN SHACKLES

Size, working load, and trademark are permanently marked on all shackles. All shackles and pins are heat treated. Loads are based on a design factor of 6 to 1. When tested all shackles are pulled at a uniform rate of speed in a direct tension.

- Meets or exceeds all requirements of ASME B30.26 including identification, ductility, design factor, proof load and temperature requirements.
- Material traceability available through Product Identification Code (PIC) System

Shackles Meet Performance Requirements of Federal Specifications RR-C-271F Type IVB* Grade A

Working Load Limit in Tons	Chain — Round Pin — Screw Pin — Safety							Estimated Weight Per 100 in lbs.
	Dimensions — Inches					O.D. Eyes (C)	Pin or Bolt Dia. (D)	
	Size Dia.	Width (A)	Tol. ±	Length (B)	Tol. ±			
1/2	1/4"	15/32"	1/16"	7/8"	1/16"	3/4"	5/16"	11
3/4	5/16"	17/32"	1/16"	1"	1/16"	7/8"	3/8"	20
1	3/8"	21/32"	1/16"	1-1/4"	1/8"	1"	7/16"	31.5
1-1/2	7/16"	23/32"	1/16"	1-1/2"	1/8"	1-1/8"	1/2"	45.5
2	1/2"	13/16"	1/16"	1-11/16"	1/8"	1-1/4"	5/8"	69.5
3-1/4	5/8"	1-1/16"	1/16"	2"	1/8"	1-5/8"	3/4"	132.5
4-3/4	3/4"	1-1/4"	1/16"	2-5/16"	1/4"	1-7/8"	7/8"	212
6-1/2	7/8"	1-7/16"	1/16"	2-7/8"	1/4"	2-1/8"	1"	320
8-1/2	1"	1-11/16"	1/16"	3-1/4"	1/4"	2-1/2"	1-1/8"	500

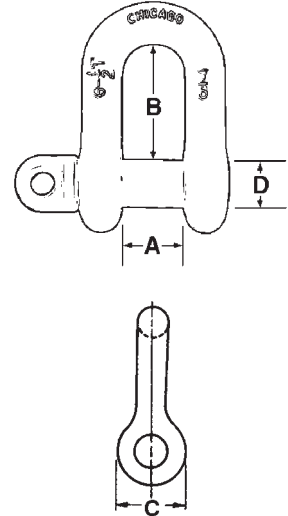

WARNING:

Any deviations such as angular lifts, shock loads, modification of the basic forging, etc., will result in drastically reduced working load limits.

All types of shackles are available in a self-colored or hot galvanized finish. When ordering specify the size, finish, and type of shackle. Other rust preventative coatings are available on a special basis.

Bolt type shackles are of the same specifications as the regular types except for the bolt, nut and cotter.

*Class 1

ROUND PIN AND COTTER



*Class 2

SCREW PIN



*Class 3

BOLT, NUT AND COTTER



Size	Galvanized Part No.	Self-Colored Part No.
1/4"	21310 3	21210 6
5/16"	21315 8	21215 1
3/8"	21320 2	21220 5
7/16"	21325 7	21225 0
1/2"	21330 1	21230 4
5/8"	21335 6	21235 9
3/4"	21340 0	21240 3
7/8"	21345 5	21245 8
1"	21350 9	21250 2

Size	Galvanized Part No.	Self-Colored Part No.
1/4"	20310 4	20210 7
5/16"	20315 9	20215 2
3/8"	20320 3	20220 6
7/16"	20325 8	20225 1
1/2"	20330 2	20230 5
5/8"	20335 7	20235 0
3/4"	20340 1	20240 4
7/8"	20345 6	20245 9
1"	20350 0	20250 3

Size	Galvanized Part No.	Self-Colored Part No.
1/4"	20810 9	20710 2
5/16"	20815 4	20715 7
3/8"	20820 8	20720 1
7/16"	20825 3	20725 6
1/2"	20830 7	20730 0
5/8"	20835 2	20735 5
3/4"	20840 6	20740 9
7/8"	20845 1	20745 4
1"	20850 5	20750 8



DROP FORGED WIRE ROPE CLIPS



“CHICAGO” the Trade-Mark of quality in wire rope fittings is on all forged steel clip bases. This identification symbolizes wire rope clips that are manufactured to rigid specifications. Component parts are galvanized. U-bolts, with or without nuts, prices on application.

- Meets performance requirements of federal specification FF-C-450, Type 1, Class1.
- Meets or exceeds all requirements of ASME B30.26 including identification, ductility, design factor, proof load and temperature requirements.



Efficiency rating of a properly applied termination is 80% for 1/8" through 7/8" and 90% for sizes 1" through 1-1/2".
Should be used in heavy duty applications

Rope Size	Hot Galvanized	U-Bolt Dimensions				Weight Per 100
	Part No.	A	B	C	T	
1/8"	23460 3	12-24	3/4"	9/32"	1/2"	6.5
3/16"	23465 8	1/4"-20	15/16"	5/16"	5/8"	10
1/4"	23470 2	5/16"-18	1-5/32"	3/8"	3/4"	18.5
5/16"	23475 7	3/8"-16	1-1/2"	1/2"	1"	29.5
3/8"	23480 1	7/16"-14	1-5/8"	9/16"	1-7/8"	44
7/16"	23485 6	1/2"-13	2-1/8"	11/16"	1-3/8"	64
1/2"	23490 0	1/2"-13	2-1/8"	11/16"	1-3/8"	75
9/16"	23495 5	9/16"-12	2-3/8"	3/4"	1-3/8"	106
5/8"	23500 6	9/16"-12	2-3/8"	3/4"	1-3/8"	106
3/4"	23505 1	5/8"-11	2-3/4"	7/8"	1-5/8"	153
7/8"	23510 5	3/4"-10	3-1/4"	1"	1-7/8"	237.5
1"	23515 0	3/4"-10	3-5/8"	1-1/8"	2"	272.5
1-1/8"	23520 4	3/4"-10	3-13/16"	1-1/4"	2-1/4"	325
1-1/4"	23525 9	7/8"-9	4-3/8"	1-11/32"	2-1/2"	441
1-1/2"	23535 8	7/8"-9	5-1/8"	1-11/16"	2-3/4"	550

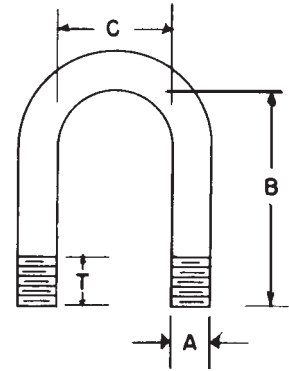

NOTE: Hex Nuts are imported – Domestic Nuts are available, price on application.

1



2



3



RECOMMENDED APPLICATION FOR CHICAGO DROP FORGED WIRE ROPE CLIPS

Clip Size Inches	Minimum No. of Clips	Amount of Rope to Turn Back in Inches	Torque in Ft. Lbs.
1/8"	2	3-1/4"	4.5
3/16"	2	3-3/4"	7.5
1/4"	2	4-3/4"	15
5/16"	2	5-1/4"	30
3/8"	2	6-1/2"	45
7/16"	2	7"	65
1/2"	3	11-1/2"	65
9/16"	3	12"	95
5/8"	3	12"	95
3/4"	4	18"	130
7/8"	4	19"	225
1"	5	26"	225
1-1/8"	6	34"	225
1-1/4"	7	44"	360
1-1/2"	8	54"	360

1. The correct way to attach wire rope clips is illustrated above. Apply the first clip one base width from the dead end of the wire rope. The base or saddle should bear on the live end of the rope – U-bolt on the short end. Tighten nuts firmly.

2. Attach second clip as close to loop as possible. Tighten nuts but not firmly.

3. Attach balance of clips spaced equally between first two clips. Tighten all nuts completely. Apply initial load – inspect nuts and retighten. Inspect all clips periodically.

The number of clips shown is based on using right regular or Lang lay wire rope, 6x19 class or 6x37 class, fibre core IWRC, IPS or XIPS. The number of clips shown also applies to right regular lay wire rope, 8x19 class and 18x7 class, fibre core, IPS or XIPS, sizes 1-1/2-inch and smaller.

If Seale construction or similar large outer wire type construction in the 6x19 class is to be used for sizes 1-inch and larger, add one additional clip. For other classes or wire rope not mentioned, it may be necessary to add additional clips to the number shown. If more clips are used than shown, amount of rope turn back should be increased proportionately.



CHICAGO GRIP CLIP

- Product Identification Codes (PIC Code), product size, and "CHF" are forged into each base.
- Meets performance requirements of federal specification FF-C-450, Type 3, Class1.
- Chicago grip clips have an 80% efficiency rating when proper application instructions followed.
- Forged with a single piece design and used in pairs with heavy duty nuts.
- Meets or exceeds all requirements of ASME B30.26 including identification, ductility, design factor, proof load and temperature requirements.



Size	Min. No. of Clips	Rope Turn Back (in.)	Torque (ft/lbs)
5/16"	2	5	30
3/8"	2	5.5	45

Size	Part No.	A	B	C	D	E	Weight Per 100 (lbs)
5/16"	71820 2	1.41	1.84	0.41	1.09	0.38	28
3/8"	71823 3	1.72	2.70	0.50	1.13	0.40	40

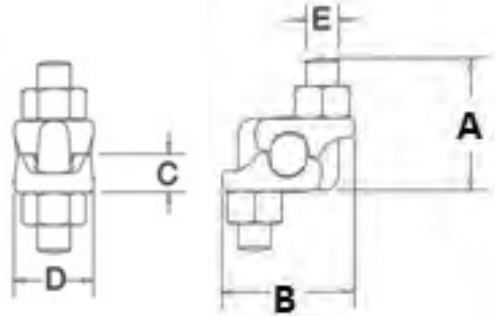

CHICAGO GRIP CLIP APPLICATION INSTRUCTIONS

- Match the same Grip Clip Size to the Wire Rope Size
- Do Not mismatch with other manufacturers wire rope clips
- Do not use on plastic coated ropes

Efficiency ratings for wire rope terminations are based upon the minimum breaking strength of wire rope. The efficiency rating of a properly prepared termination of clip sizes 5/16" or 3/8" is 80%.

Application Information

1. Refer to table above in for application instructions. Turn back specified amount of rope from loop or thimble. Apply first clip one base width from dead end of wire rope. Use torque wrench to tighten nuts evenly, alternating from one nut to the other of the same clip until reaching the recommended torque. (See Figure 1)
2. Apply the second Grip Clip as near the loop or thimble as possible. Turn nuts to firm and then use torque wrench to tighten nuts on the clip evenly, alternating from one nut to the other on the second clip making sure that the recommended torque is met. (See Figure 2)
3. Apply first load to test the assembly. The load should be of equal to or greater weight than loads expected in use. Follow up applying the load with using a torque wrench to again check that the nuts are torqued to the recommended values in the above table.
4. As with all good rigging practice, the wire rope termination should be inspected periodically for wear, abuse and general adequacy.

WARNING

- Read and understand instructions prior to usage
- Failure to read, understand, and follow instructions may lead to death or serious injury.
- Apply first load to test assembly. This load should be greater than or equal to the weight of expected loads.



Figure 1



Figure 2

MALLEABLE WIRE ROPE CLIPS

Clips supplied with self-colored, galvanized or hot galvanized finish. U-bolts for clips are available with or without nuts — price on application. Some sizes available in Stainless Steel. See page 41. Meets Performance Requirements of Federal Specification FF-C-450, Type 1, Class 2.



Rope Size	Self-Colored Part No.	Galvanized Part No.	Hot Galvanized Part No.	U-Bolt Dimensions				Weight Per 100
				A	B	C	T	
3/32"	23005 6	23155 8	N.A.	10-24	3/4"	19/64"	1/2"	3.7
1/8"	23010 0	23160 2	N.A.	1/4"-20	15/16"	5/16"	5/8"	6.5
3/16"	23015 5	23165 7	N.A.	1/4"-20	15/16"	5/16"	5/8"	6.8
1/4"	23020 9	23170 1	23320 0	5/16"-18	1-5/32"	3/8"	3/4"	12.2
5/16"	23025 4	23175 6	23325 5	5/16"-18	1-5/32"	3/8"	3/4"	12.2
3/8"	23030 8	23180 0	23330 9	3/8"-16	1-1/2"	1/2"	1"	18.5
7/16"	23035 3	23185 5	23335 4	3/8"-16	1-1/2"	1/2"	1"	24
1/2"	23040 7	23190 9	23340 8	7/16"-14	1-13/16"	9/16"	1-1/8"	33.3
9/16"	23045 2	23195 4	23345 3	1/2"-13	2-1/8"	11/16"	1-3/8"	51.5
5/8"	23050 6	23200 5	23350 7	1/2"-13	2-1/8"	11/16"	1-3/8"	55.9
3/4"	23055 1	23205 0	23355 2	9/16"-12	2-11/16"	3/4"	1-5/8"	80.8
7/8"	23060 5	23210 4	23360 6	5/8"-11	3-1/4"	1-1/8"	1-7/8"	140
1"	23065 0	23215 9	23365 1	5/8"-11	3-1/4"	1-1/8"	1-7/8"	150
1-1/8"	23070 4	23220 3	N.A.	3/4"-10	4-3/8"	1-5/16"	2-1/2"	263
1-1/4"	23075 9	23225 8	N.A.	3/4"-10	4-3/8"	1-5/16"	2-1/2"	300
1-3/8"	23080 3	23230 2	N.A.	7/8"-9	5-1/8"	1-11/16"	2-3/4"	441
1-1/2"	23085 8	23235 7	N.A.	7/8"-9	5-1/8"	1-11/16"	2-3/4"	488
1-3/4"	23095 7	23245 6	N.A.	1"-8	6-1/4"	2-1/16"	3-3/4"	899.5
2"	23100 8	23250 0	N.A.	1"-8	7-1/4"	2-1/2"	4"	1285

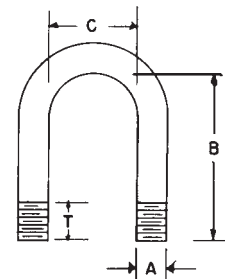

NOTE: Hex Nuts are imported. Domestic Nuts are available, price on application.

Should be used only in light duty applications

WIRE ROPE THIMBLES



Available in closed or open pattern with galvanized finish.



STANDARD

CLOSED

OPEN

Rope Diameter	Closed Part No.	Open Part No.	Dimensions - Inches					Weight Per 100
			Length		Width			
			Overall	Inside	Inside	Opening	Inside score	
1/8"	22505 2	22405 5	1-5/8"	1-7/32"	19/32"	3/8"	3/16"	2.1
3/16"	22510 6	22410 9	1-5/8"	1-7/32"	19/32"	3/8"	7/32"	2.1
1/4"	22515 1	22415 4	1-7/8"	1-3/8"	11/16"	1/2"	1/4"	3.4
5/16"	22520 5	22420 8	2-1/8"	1-1/2"	3/4"	5/8"	5/16"	4.6
3/8"	22525 0	22425 3	2-5/8"	1-7/8"	7/8"	5/8"	13/32"	9
7/16"	22530 4	22430 7	2-3/4"	1-7/8"	1-1/16"	3/4"	15/32"	17
1/2"	22535 9	22435 2	2-7/8"	2"	1-1/8"	3/4"	19/32"	17
5/8"	22540 3	22440 6	3-3/8"	2-7/32"	1-5/16"	7/8"	23/32"	30
3/4"	22545 8	22445 1	3-7/8"	2-1/2"	1-1/2"	1"	13/16"	39.5
7/8"	22550 2	22450 5	4-9/16"	3"	1-11/16"	1-1/8"	15/16"	58.5
1"	22555 7	22455 0	5"	3-7/32"	2"	1-1/8"	1-1/8"	96
1-1/8"	22560 1	N.A.	5-3/8"	3-9/16"	2-1/4"	N.A.	1-1/4"	108.5
1-1/4"	22565 6	N.A.	5-3/4"	3-9/16"	2-7/16"	N.A.	1-5/16"	145.5
1-1/2"	22570 0	N.A.	7"	4-5/16"	2-7/8"	N.A.	1-9/16"	246.5
1-3/4"	22575 5	N.A.	8-1/2"	5-1/4"	3-5/16"	N.A.	1-7/8"	460
2"	22580 9	N.A.	10"	6-5/8"	3-1/2"	N.A.	2-3/32"	590

Recommended for light duty applications.

Some sizes also available in Stainless Steel. See page 41.

HEAVY DUTY



Rope Diameter	Part No.	Dimensions - Inches				Weight Per 100
		Length		Width		
		Overall	Inside	Inside	Inside score	
1/4"	22105 4	2-3/16"	1-5/8"	7/8"	1/4"	6.5
5/16"	22110 8	2-1/2"	1-7/8"	1-1/16"	11/32"	11.8
3/8"	22115 3	2-7/8"	2-1/8"	1-1/8"	13/32"	21.6
7/16"	22120 7	3-1/4"	2-3/8"	1-1/4"	15/32"	34.7
1/2"	22125 2	3-5/8"	2-3/4"	1-1/2"	17/32"	51
9/16"-5/8"	22130 6	4-1/4"	3-1/4"	1-3/4"	21/32"	51
3/4"	22135 1	5"	3-3/4"	2"	25/32"	158
7/8"	22140 5	5-1/2"	4-1/4"	2-1/4"	15/16"	178
1"	22145 0	6-1/8"	4-1/2"	2-1/2"	1-1/16"	314
1-1/8"-1-1/4"	22150 4	7"	5-1/8"	2-7/8"	1-5/16"	400
1-3/8"-1-1/2"	22155 9	9"	6-1/4"	3-1/2"	1-9/16"	1295

Recommended for heavy duty applications.



DROP FORGED EYE BOLTS

Regular (pg 14), shoulder (pg 15) and screw thread (pg. 17) drop forged heat treated steel eye bolts supplied as standard with hot galvanized finish. Machine thread eye bolts are threaded National Coarse before galvanizing and assembled with hex nuts tapped oversize. Regular Nut Eyebolts and Shoulder Nut Eyebolts loads are based on in-line loads with a design factor of 5 to 1. When tested all eye bolts are pulled at a uniform rate of speed in a direct tension.

REGULAR – MACHINE THREAD

Diameter (A) & Shank Length (B)	Part No.	Dimensions – Inches				Weight Per 100 pcs	Working Load Limit
		Outside Eye (C)	Inside Eye (D)	Overall Length (E)	Thread Length (T)		
1/4" x 2"	08005 7	1"	1/2"	3"	1-1/2"	6.4	500
1/4" x 3"	08008 8	1"	1/2"	4"	1-1/2"	8	500
1/4" x 4"	08011 8	1"	1/2"	5"	2"	9.3	500
1/4" x 5"	08014 9	1"	1/2"	6"	2-1/2"	10.4	500
1/4" x 6"	08017 0	1"	1/2"	7"	3"	11.8	500
5/16" x 2-1/4"	08022 4	1-1/4"	5/8"	3-1/2"	1-1/2"	12.7	800
5/16" x 3-1/4"	08025 5	1-1/4"	5/8"	4-1/2"	1-1/2"	15	800
5/16" x 4-1/4"	08028 6	1-1/4"	5/8"	5-1/2"	2-1/2"	16.5	800
5/16" x 5"	08031 6	1-1/4"	5/8"	6-1/4"	2-1/2"	18.6	800
5/16" x 6"	08034 7	1-1/4"	5/8"	7-1/4"	3"	24.5	800
3/8" x 2-1/2"	08039 2	1-1/2"	3/4"	4"	1-1/2"	19.2	1200
3/8" x 3"	08042 2	1-1/2"	3/4"	4-1/2"	1-1/2"	21.2	1200
3/8" x 4-1/4"	08045 3	1-1/2"	3/4"	6"	2"	24.4	1200
3/8" x 5"	08048 4	1-1/2"	3/4"	6-1/2"	2-1/2"	27.8	1200
3/8" x 6"	08051 4	1-1/2"	3/4"	7-1/2"	3"	30	1200
3/8" x 8"	08054 5	1-1/2"	3/4"	9-1/2"	4"	36	1200
1/2" x 2"	08059 0	2"	1"	4"	1-7/8"	38.5	2200
1/2" x 3-1/4"	08062 0	2"	1"	5-1/4"	1-1/2"	46	2200
1/2" x 4-1/2"	08065 1	2"	1"	6-1/2"	2"	53	2200
1/2" x 6"	08068 2	2"	1"	8"	3"	60	2200
1/2" x 8"	08071 2	2"	1"	10"	4"	71	2200
1/2" x 10"	08074 3	2"	1"	12"	4"	83	2200
1/2" x 12"	08077 4	2"	1"	14"	4"	96	2200
5/8" x 4-1/2"	08082 8	2-5/16"	1-1/4"	6-13/16"	2"	79	3500
5/8" x 6"	08085 9	2-5/16"	1-1/4"	8-5/16"	3"	96	3500
5/8" x 8"	08088 0	2-5/16"	1-1/4"	10-5/16"	4"	128	3500
5/8" x 10"	08091 0	2-5/16"	1-1/4"	12-5/16"	4"	129.5	3500
5/8" x 12"	08094 1	2-5/16"	1-1/4"	14-5/16"	4"	146	3500
5/8" x 15"	08097 2	2-5/16"	1-1/4"	17-5/16"	6"	168	3500
5/8" x 18"	08100 9	2-5/16"	1-1/4"	20-5/16"	6"	195	3500
5/8" x 24"	08103 0	2-5/16"	1-1/4"	26-5/16"	6"	246	3500
3/4" x 4-1/2"	08108 5	2-3/4"	1-1/2"	7-1/4"	2-1/2"	126	5200
3/4" x 6"	08111 5	2-3/4"	1-1/2"	8-3/4"	3"	160	5200
3/4" x 8"	08114 6	2-3/4"	1-1/2"	10-3/4"	4"	180	5200
3/4" x 10"	08117 7	2-3/4"	1-1/2"	12-3/4"	4"	200	5200
3/4" x 12"	08120 7	2-3/4"	1-1/2"	14-3/4"	4"	233	5200
3/4" x 15"	08123 8	2-3/4"	1-1/2"	17-3/4"	6"	254	5200
3/4" x 18"	08126 9	2-3/4"	1-1/2"	20-3/4"	6"	290	5200
3/4" x 24"	08129 0	2-3/4"	1-1/2"	26-3/4"	6"	369	5200
7/8" x 5"	08134 4	3-1/2"	1-3/4"	8-1/2"	2-1/2"	245	7200
7/8" x 8"	08137 5	3-1/2"	1-3/4"	11-1/2"	4"	296	7200
7/8" x 12"	08140 5	3-1/2"	1-3/4"	15-1/2"	4"	366	7200
7/8" x 18"	08143 6	3-1/2"	1-3/4"	21-1/2"	6"	464	7200
7/8" x 24"	08146 7	3-1/2"	1-3/4"	27-1/2"	6"	556	7200
1" x 6"	08151 1	3-3/4"	2"	9-3/4"	3"	301	10000
1" x 9"	08154 2	3-3/4"	2"	12-3/4"	4"	383	10000
1" x 12"	08157 3	3-3/4"	2"	15-3/4"	4"	450	10000
1" x 18"	08160 3	3-3/4"	2"	21-3/4"	6"	584	10000
1" x 24"	08163 4	3-3/4"	2"	27-3/4"	6"	716	10000

- Meets or exceeds all requirements of ASME B30.26 including identification, ductility, design factor, proof load and temperature requirements.
- Material traceability available through Product Identification Code (PIC) System



WARNING:

Any deviations such as angular lifts, shock loads, modification of the basic forging, etc., will result in drastically reduced working load limits.

Special shank and thread lengths are also available.

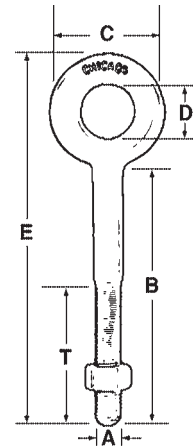

Some sizes also available in Stainless Steel. See pg. 41.



NOTE: Hex Nuts are imported

DROP FORGED EYE BOLTS

MACHINE THREAD (As noted on page 14)



- Meets or exceeds all requirements of ASME B30.26 including identification, ductility, design factor, proof load and temperature requirements.
- Material traceability available through Product Identification Code (PIC) System

WARNING:

Any deviations such as angular lifts, shock loads, modification of the basic forging, etc., will result in drastically reduced working load limits.

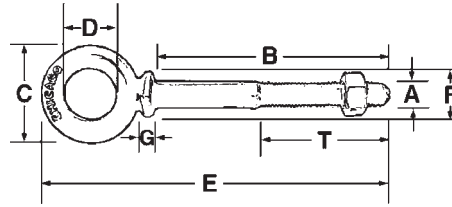

SHOULDER

Diameter (A) & Shank Length (B)	Part No.	Dimensions - Inches						Weight Per 100 pcs	Working Load Limit†
		Outside Eye (C)	Inside Eye (D)	Overall Length (E)	Outside Shoulder (F)	Thickness at Shoulder (G)	Thread Length (T)		
1/4" x 2	08405 5	1"	1/2"	3-1/8"	7/16"	5/64"	1-1/2"	7.4	500
1/4" x 3	08408 6	1"	1/2"	4-1/8"	7/16"	5/64"	1-1/2"	9	500
1/4" x 4	08411 6	1"	1/2"	5-1/8"	7/16"	5/64"	2"	10.7	500
5/16" x 2-1/4"	08422 2	1-1/4"	5/8"	3-5/8"	9/16"	3/32"	1-1/2"	12.9	800
5/16" x 3-1/4"	08425 3	1-1/4"	5/8"	4-5/8"	9/16"	3/32"	1-1/2"	16	800
5/16" x 4-1/4"	08428 4	1-1/4"	5/8"	5-5/8"	9/16"	3/32"	2-1/2"	16.8	800
3/8" x 2-1/2"	08439 0	1-1/2"	3/4"	4-1/4"	11/16"	1/8"	1-1/2"	21	1200
3/8" x 3"	08442 0	1-1/2"	3/4"	4-3/4"	11/16"	1/8"	1-1/2"	23	1200
3/8" x 4-1/2"	08445 1	1-1/2"	3/4"	6-1/4"	11/16"	1/8"	2"	29	1200
3/8" x 5"	08448 2	1-1/2"	3/4"	6-3/4"	11/16"	1/8"	2-1/2"	29	1200
3/8" x 6"	08451 2	1-1/2"	3/4"	7-3/4"	11/16"	1/8"	3"	32	1200
3/8" x 8"	08454 3	1-1/2"	3/4"	9-3/4"	11/16"	1/8"	4"	37	1200
1/2" x 2"	08459 8	2"	1"	4-5/16"	7/8"	5/32"	1-7/8"	44	2200
1/2" x 3-1/4"	08462 8	2"	1"	5-1/2"	7/8"	5/32"	1-1/2"	46	2200
1/2" x 4-1/2"	08465 9	2"	1"	6-3/4"	7/8"	5/32"	2"	60	2200
1/2" x 6"	08468 0	2"	1"	8-1/4"	7/8"	5/32"	3"	64	2200
1/2" x 8"	08471 0	2"	1"	10-1/4"	7/8"	5/32"	4"	78	2200
1/2" x 10"	08474 1	2"	1"	12-1/4"	7/8"	5/32"	4"	89	2200
1/2" x 12"	08477 2	2"	1"	14-1/4"	7/8"	5/32"	4"	103	2200
5/8" x 4-1/2"	08482 6	2-5/16"	1-1/4"	7-1/4"	1-1/8"	13/64"	2"	99	3500
5/8" x 6"	08485 7	2-5/16"	1-1/4"	8-9/16"	1-1/8"	13/64"	3"	103	3500
5/8" x 8"	08488 8	2-5/16"	1-1/4"	10-9/16"	1-1/8"	13/64"	4"	124	3500
5/8" x 10"	08491 8	2-5/16"	1-1/4"	12-9/16"	1-1/8"	13/64"	4"	142	3500
5/8" x 12"	08494 9	2-5/16"	1-1/4"	14-9/16"	1-1/8"	13/64"	4"	160	3500
3/4" x 4-1/2"	08508 3	2-3/4"	1-1/2"	7-3/4"	1-3/8"	1/4"	2-1/2"	152	5200
3/4" x 6"	08511 3	2-3/4"	1-1/2"	9-1/8"	1-3/8"	1/4"	3"	166	5200
7/8" x 5"	08534 2	3-1/2"	1-3/4"	9-1/4"	1-1/2"	9/32"	2-1/2"	222	7200
7/8" x 8"	08537 3	3-1/2"	1-3/4"	12-1/8"	1-1/2"	9/32"	4"	269	7200
1" x 6"	08551 9	3-3/4"	2"	10-1/2"	1-3/4"	5/16"	3"	331	10000
1" x 9"	08554 0	3-3/4"	2"	13-1/4"	1-3/4"	5/16"	4"	404	10000



NOTE:
Hex Nuts are imported

† Loads are based on a design factor of 5 to 1. Some sizes also available in Stainless Steel. See page 41. Special shank and thread lengths are also available.



DROP FORGED *RING BOLTS

Ring bolts are only available in hot galvanized finish. Eye bolts are drop forged steel; eye bolt specifications are identical to those shown on pages 14-15. Ring dimensions are shown in table below. **RING BOLTS ARE NOT TO BE USED FOR LIFTING APPLICATIONS.**

REGULAR – MACHINE THREAD

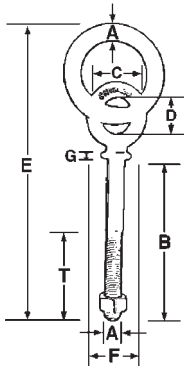

Diameter (A) & Shank Length (B)	Part No.	Dimensions – Inches					Weight Per 100 pcs	Working Load Limit
		O.D. Eye of Bolt (C)	I.D. Eye of Bolt (D)	I.D. Eye of Ring	Overall Length (E)	Thread Length (T)		
1/4" x 2"	09205 0	1"	1/2"	1-3/4"	4-3/4"	1-1/2"	16	250
1/4" x 4"	09211 1	1"	1/2"	1-3/4"	6-3/4"	2"	18	250
5/16" x 2-1/4"	09216 6	1-1/4"	5/8"	2"	5-1/2"	1-1/2"	29	400
5/16" x 4-1/4"	09219 7	1-1/4"	5/8"	2"	7-1/2"	2-1/2"	32.5	400
3/8" x 2-1/2"	09224 1	1-1/2"	3/4"	2-1/2"	6-1/2"	1-1/2"	47.5	600
3/8" x 4-1/4"	09227 2	1-1/2"	3/4"	2-1/2"	8-1/4"	2"	52	600
3/8" x 6"	09230 2	1-1/2"	3/4"	2-1/2"	10"	3"	56	600
3/8" x 8"	09233 3	1-1/2"	3/4"	2-1/2"	12"	4"	62	600
1/2" x 3-1/4"	09238 8	2"	1"	3"	8-1/4"	1-1/2"	108	1100
1/2" x 6"	09241 8	2"	1"	3"	11"	3"	121	1100
1/2" x 8"	09244 9	2"	1"	3"	13"	4"	135.5	1100
1/2" x 10"	09247 0	2"	1"	3"	15"	4"	142.5	1100
5/8" x 4-1/2"	09252 4	2-5/16"	1-1/4"	2-3/4"	9-9/16"	2"	175	1750
5/8" x 6"	09255 5	2-5/16"	1-1/4"	2-3/4"	11-1/16"	3"	190	1750
5/8" x 8"	09258 6	2-5/16"	1-1/4"	2-3/4"	13-1/16"	4"	200	1750
5/8" x 10"	09261 6	2-5/16"	1-1/4"	2-3/4"	15-1/16"	4"	231	1750
5/8" x 12"	09264 7	2-5/16"	1-1/4"	2-3/4"	17-1/16"	4"	242	1750
3/4" x 4-1/2"	09269 2	2-3/4"	1-1/2"	3"	10-1/4"	2-1/2"	281	2600
3/4" x 6"	09272 2	2-3/4"	1-1/2"	3"	11-3/4"	3"	311.5	2600
3/4" x 8"	09275 3	2-3/4"	1-1/2"	3"	13-3/4"	4"	312.5	2600
3/4" x 10"	09278 4	2-3/4"	1-1/2"	3"	15-3/4"	4"	315	2600
3/4" x 12"	09281 4	2-3/4"	1-1/2"	3"	17-3/4"	4"	317.5	2600
7/8" x 5"	09286 9	3-1/2"	1-3/4"	3-1/4"	11-1/2"	2-1/2"	520	3500
7/8" x 8"	09289 0	3-1/2"	1-3/4"	3-1/4"	14-1/2"	4"	538	3500
1" x 6"	09294 4	3-3/4"	2"	3-3/4"	13-1/2"	3"	645	4900
1" x 9"	09297 5	3-3/4"	2"	3-3/4"	16-1/2"	4"	741	4900

NOTE: All Rings are Welded

Hex Nuts are imported – Domestic Nuts are available, price on application.



SHOULDER – MACHINE THREAD

Diameter (A) & Shank Length (B)	Part No.	Dimensions – Inches							Weight Per 100 pcs	Working Load Limit
		O.D. Eye of Bolt (C)	I.D. Eye of Bolt (D)	I.D. Eye of Ring	Overall Length (E)	Outside Shoulder (F)	Thickness at Shoulder (G)	Thread Length (T)		
1/4" x 2"	09505 1	1"	1/2"	1-3/4"	4-3/4"	7/16"	5/64"	1-1/2"	17	250
1/4" x 4"	09511 2	1"	1/2"	1-3/4"	6-1/4"	7/16"	5/64"	2"	19	250
5/16" x 2-1/4"	09516 7	1-1/4"	5/8"	2"	5-3/4"	9/16"	3/32"	1-1/2"	30	400
5/16" x 4-1/4"	09519 8	1-1/4"	5/8"	2"	6-5/8"	9/16"	3/32"	2"	33.5	400
3/8" x 2-1/2"	09524 2	1-1/2"	3/4"	2-1/2"	6-1/2"	11/16"	1/8"	1-1/2"	51	600
3/8" x 4-1/2"	09527 3	1-1/2"	3/4"	2-1/2"	8-3/4"	11/16"	1/8"	2"	58	600
1/2" x 3-1/4"	09538 9	2"	1"	3"	8-7/16"	7/8"	5/32"	1-1/2"	115	1100
1/2" x 6"	09541 9	2"	1"	3"	11"	7/8"	5/32"	3"	127	1100
5/8" x 4-1/2"	09552 5	2-5/16"	1-1/4"	2-3/4"	10"	1-1/8"	13/64"	2"	187.5	1750
5/8" x 6"	09555 6	2-5/16"	1-1/4"	2-3/4"	11-1/2"	1-1/8"	13/64"	3"	208	1750
3/4" x 4-1/2"	09569 3	3"	1-1/2"	3"	11"	1-3/8"	1/4"	2-1/2"	288	2600
3/4" x 6"	09572 3	3"	1-1/2"	3"	12-1/8"	1-3/8"	1/4"	3"	310	2600
7/8" x 5"	09586 0	3-1/2"	1-3/4"	3-1/4"	12"	1-1/2"	9/32"	2-1/2"	445	3500
7/8" x 8"	09589 1	3-1/2"	1-3/4"	3-1/4"	15"	1-1/2"	9/32"	4"	482	3500
1" x 6"	09594 5	3-3/4"	2"	3-3/4"	14"	1-3/4"	5/16"	3"	681	4900
1" x 9"	09597 6	3-3/4"	2"	3-3/4"	17"	1-3/4"	5/16"	4"	750	4900

DROP FORGED *RING BOLTS



Ring bolts are only available in hot galvanized finish. Eye bolts are drop forged steel; screw thread eye bolt specifications are identical to those shown below. Ring dimensions are shown in table below. **RING BOLTS ARE NOT TO BE USED FOR LIFTING APPLICATIONS.**



REGULAR – SCREW THREAD

Diameter (A) & Shank Length (B)	Part No.	Dimensions – Inches					Weight Per 100 pcs
		O.D. Eye of Bolt (C)	I.D. Eye of Bolt (D)	I.D. Eye of Ring	Overall Length (E)	Thread Length (T)	
1/4" x 2"	09005 6	1"	1/2"	1-3/4"	4-3/4"	1-1/2"	16.7
5/16" x 2-1/4"	09010 0	1-1/4"	5/8"	2"	5-1/2"	1-5/8"	25.9
3/8" x 2-1/2"	09015 5	1-1/2"	3/4"	2-1/2"	6-1/2"	1-3/4"	44.3
1/2" x 3-1/4"	09020 9	2"	1"	3"	8-1/4"	2-1/8"	100.7
5/8" x 4-1/2"	09025 4	2-5/16"	1-1/4"	2-3/4"	9-9/16"	2-1/2"	162
3/4" x 4-1/2"	09030 8	2-3/4"	1-1/2"	3"	10-1/4"	3"	253
7/8" x 5"	09035 3	3-1/4"	1-3/4"	3-1/4"	11-1/2"	3-1/4"	403
1" x 6"	09040 7	3-3/4"	2"	3-3/4"	13-1/2"	3-1/2"	599

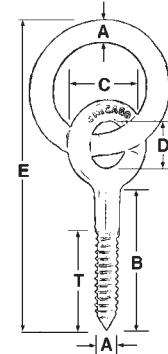

NOTE: All Rings are Welded



SHOULDER – SCREW THREAD

Diameter (A) & Shank Length (B)	Part No.	Dimensions – Inches							Weight Per 100 pcs
		O.D. Eye of Bolt (C)	I.D. Eye of Bolt (D)	I.D. Eye of Ring	Overall Length (E)	Outside Shoulder (F)	Thickness at Shoulder (G)	Thread Length (T)	
1/4" x 2"	09105 3	1"	1/2"	1-3/4"	4-3/4"	7/16"	5/64"	1-1/2"	15.3
5/16" x 2-1/4"	09110 7	1-1/4"	5/8"	2"	5-1/2"	9/16"	3/32"	1-5/8"	28.9
3/8" x 2-1/2"	09115 2	1-1/2"	3/4"	2-1/2"	6-1/2"	11/16"	1/8"	1-3/4"	45.8
1/2" x 3-1/4"	09120 6	2"	1"	3"	8-1/4"	7/8"	5/32"	2-1/8"	105.8
5/8" x 4-1/2"	09125 1	2-5/16"	1-1/4"	2-3/4"	10-1/4"	1-1/8"	13/64"	2-1/2"	170
3/4" x 4-1/2"	09130 5	2-3/4"	1-1/2"	3"	11"	1-3/8"	1/4"	3"	272
7/8" x 5"	09135 0	3-1/4"	1-3/4"	3-1/4"	12"	1-1/2"	9/32"	3-1/4"	429
1" x 6"	09140 4	3-3/4"	2"	3-3/4"	14-1/2"	1-3/4"	5/16"	3-1/2"	647

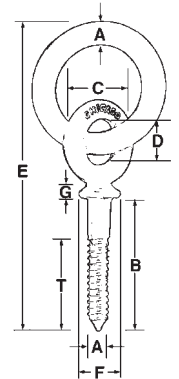

NOTE: All Rings are Welded

SCREW THREAD EYE BOLTS

REGULAR

Diameter (A) & Shank Length (B)	Part No.	Dimensions – Inches				Weight Per 100 pcs
		Outside Eye (C)	Inside Eye (D)	Overall Length (E)	Thread Length (T)	
1/4" x 2"	08805 3	1"	1/2"	3"	1-1/2"	5.3
5/16" x 2-1/4"	08810 7	1-1/4"	5/8"	3-1/2"	1-5/8"	9
3/8" x 2-1/2"	08815 2	1-1/2"	3/4"	4"	1-3/4"	16
1/2" x 3-1/4"	08820 6	2"	1"	5-1/4"	2-1/8"	39
5/8" x 4-1/2"	08825 1	2-5/16"	1-1/4"	6-13/16"	2-1/2"	67
3/4" x 4-1/2"	08830 5	2-3/4"	1-1/2"	7-1/4"	3"	108
7/8" x 5"	08835 0	3-1/2"	1-3/4"	8-1/4"	3-1/4"	166
1" x 6"	08840 4	3-3/4"	2"	9-3/4"	3-1/2"	265

Screw eye bolts supplied with cone points – lag screw thread.

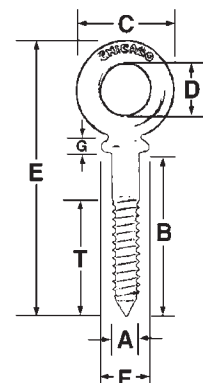

SHOULDER

Diameter (A) & Shank Length (B)	Part No.	Dimensions – Inches						Weight Per 100 pcs
		Outside Eye (C)	Inside Eye (D)	Overall Length (E)	Outside Shoulder (F)	Thickness at Shoulder (G)	Thread Length (T)	
1/4" x 2"	08905 0	1"	1/2"	3-1/8"	7/16"	5/64"	1-1/2"	6.7
5/16" x 2-1/4"	08910 4	1-1/4"	5/8"	3-3/4"	9/16"	3/32"	1-5/8"	12
3/8" x 2-1/2"	08915 9	1-1/2"	3/4"	4-1/4"	11/16"	1/8"	1-3/4"	19
1/2" x 3-1/4"	08920 3	2"	1"	5-1/2"	7/8"	5/32"	2-1/8"	42
5/8" x 4-1/2"	08925 8	2-5/16"	1-1/4"	7-1/4"	1-1/8"	13/64"	2-1/2"	86
3/4" x 4-1/2"	08930 2	2-3/4"	1-1/2"	7-3/4"	1-3/8"	1/4"	3"	120
7/8" x 5"	08935 7	3-1/2"	1-3/4"	9"	1-1/2"	9/32"	3-1/4"	189
1" x 6"	08940 1	3-3/4"	2"	10-1/2"	1-3/4"	5/16"	3-1/2"	297



MACHINERY EYE BOLTS

Maximum blank lengths, either pattern indicated in column (1). Vertical loads are based on a design factor of 5 to 1. Variation in quantity: on special items we reserve the right to a maximum 10% variation for allowances in manufacture. Finishes include zinc plated, hot galvanized and black oxide.

- Meets or exceeds all requirements of ASME B30.26 including identification, ductility, design factor, proof load and temperature requirements.
- Material traceability available through Product Identification Code (PIC) System

STANDARD SHANK LENGTHS – PLAIN & SHOULDER PATTERN – CARBON STEEL AND STAINLESS STEEL

Stock Numbers		Dimensions – Inches						
Plain Pattern	Shoulder Pattern	Shank		Eye		Overall Length Plain	Overall Length Shoulder	Maximum Lengths (1)
		Dia. & Thread	Length	I.D.	O.D.			
1	21	1/4"-20	1"	3/4"	1-1/4"	2-1/4"	2-3/8"	3"
2	22	5/16"-18	1-1/8"	7/8"	1-1/2"	2-5/8"	2-3/4"	4"
3	23	3/8"-16	1-1/4"	1"	1-21/32"	2-29/32"	3-1/4"	4-1/2"
4	24	7/16"-14	1-3/8"	1-3/32"	1-27/32"	3-7/32"	3-5/8"	4-1/2"
5	25	1/2"-13	1-1/2"	1-3/16"	2-1/16"	3-9/16"	4"	4-1/2"
6	26	9/16"-12	1-5/8"	1-9/32"	2-9/32"	3-29/32"	4-1/2"	4-1/2"
7	27	5/8"-11	1-3/4"	1-3/8"	2-1/2"	4-1/4"	4-7/8"	4-1/2"
8	28	3/4"-10	2"	1-1/2"	2-13/16"	4-13/16"	5-1/4"	5"
9	29	7/8"-9	2-1/4"	1-11/16"	3-1/4"	5-1/2"	6"	5"
10	30	1"-8	2-1/2"	1-13/16"	3-9/16"	6-1/16"	7"	5"
11	31	1-1/8"-7	2-3/4"	2"	4"	6-3/4"	7-1/2"	2-3/4"
12	32	1-1/4"-7	3"	2-3/16"	4-7/16"	7-7/16"	8-1/2"	3"
14	34	1-1/2"-6	3-1/2"	2-1/2"	5-3/16"	8-11/16"	9-1/2"	3-1/2"

Working load limits for eye bolts are based on a straight vertical lift in a gradually increasing manner. Angular lifts will significantly lower working load limits (see Shoulder Pattern) and should be avoided whenever possible. If an angular lift is required, a properly seated Shoulder Pattern eye bolt must be used. Loads should always be applied to eye bolts in the plane of the eye, not at an angle to this plane. Angular lifts must never be more than a 45° pull. For angular lifting see chart below.

Diameter and Thread	Working Load Limit	
	Straight Pull (X)	45° Pull (Y) Shoulder Only
1/4"-20	500	125
5/16"-18	900	225
3/8"-16	1400	350
7/16"-14	2000	500
1/2"-13	2600	650
9/16"-12	3200	800
5/8"-11	4000	1000
3/4"-10	6000	1500
7/8"-9	7000	1750
1"-8	9000	2250
1-1/8"-7	12000	3000
1-1/4"-7	15000	3750
1-1/2"-6	21000	5250

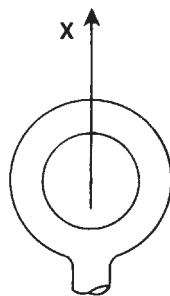

Plain Pattern

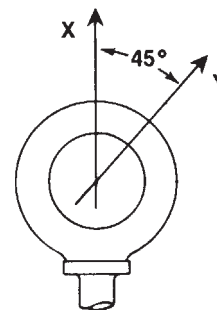

Shoulder Pattern

ANGULAR LIFTS SHOULD BE AVOIDED WHENEVER POSSIBLE.



MACHINERY EYE BOLTS



Drop forged steel. Heat treated after forging. Self-colored, zinc plated, or hot galvanized. Plain or shoulder type, blank or threaded. Threaded will be supplied unless otherwise specified. See additional specifications and dimensions on page 18.

- Meets or exceeds all requirements of ASME B30.26 including identification, ductility, design factor, proof load and temperature requirements.
- Material traceability available through Product Identification Code (PIC) System



STANDARD SHANK LENGTHS

PLAIN PATTERN



Plain Pattern No.	Bolt Diameter N.C.	Standard Shank Length	Threaded		Blank	
			Part No.	Weight Per 100	Part No.	Weight Per 100
1	1/4"	1"	11605 3	5	11005 1	5.5
2	5/16"	1-1/8"	11625 1	10.5	11025 9	11.5
3	3/8"	1-1/4"	11645 9	15.5	11045 7	16.5
4	7/16"	1-3/8"	11665 7	20.5	11065 5	22
5	1/2"	1-1/2"	11685 5	33	11085 3	35
6	9/16"	1-5/8"	11705 0	44.5	11105 8	45
7	5/8"	1-3/4"	11725 8	64	11125 6	66
8	3/4"	2"	11748 7	90.5	11148 5	97
9	7/8"	2-1/4"	11768 5	135	11168 3	142
10	1"	2-1/2"	11788 3	190.5	11188 1	199
11	1-1/8"	2-3/4"	11808 8	299.5	11208 6	312
12	1-1/4"	3"	11831 6	399	11231 4	412
14	1-1/2"	3-1/2"	11851 4	662.5	11251 2	691

Available in Zinc Plated, Hot Galvanized and Black Oxide. See page 20.

Some sizes available in Stainless Steel. See page 42.

Available in Metric See page 22.

STANDARD SHANK LENGTHS

SHOULDER PATTERN



Shoulder Pattern No.	Bolt Diameter N.C.	Standard Shank Length	Threaded		Blank	
			Part No.	Weight Per 100	Part No.	Weight Per 100
21	1/4"	1"	12805 6	6	12205 4	6
22	5/16"	1-1/8"	12825 4	10	12225 2	10.5
23	3/8"	1-1/4"	12845 2	16	12245 0	17
24	7/16"	1-3/8"	12865 0	26.5	12265 8	28
25	1/2"	1-1/2"	12885 8	38	12285 6	39
26	9/16"	1-5/8"	12905 3	49	12305 1	52.5
27	5/8"	1-3/4"	12925 1	73.5	12325 9	76.5
28	3/4"	2"	12948 0	99.5	12348 8	104
29	7/8"	2-1/4"	12968 8	172.5	12368 6	178
30	1"	2-1/2"	12988 6	235	12388 4	242
31	1-1/8"	2-3/4"	13008 0	342.5	12408 9	347
32	1-1/4"	3"	13031 8	462.5	12431 7	485
34	1-1/2"	3-1/2"	13051 6	752.5	12451 5	780



PLATED MACHINERY EYE BOLTS

- Meets or exceeds all requirements of ASME B30.26 including identification, ductility, design factor, proof load and temperature requirements.
- Material traceability available through Product Identification Code (PIC) System

ZINC PLATED

PLAIN PATTERN – ZINC

Plain Pattern No.	Bolt Diameter N.C.	Standard Shank Length	Part No.	Weight Per 100
1	1/4"	1"	26005 3	5
2	5/16"	1-1/8"	26008 4	10
3	3/8"	1-1/4"	26011 4	15.5
4	7/16"	1-3/8"	26014 5	20.5
5	1/2"	1-1/2"	26017 6	33
6	9/16"	1-5/8"	26020 6	44.5
7	5/8"	1-3/4"	26023 7	64
8	3/4"	2"	26026 8	90.5
9	7/8"	2-1/4"	26029 9	135
10	1"	2-1/2"	26032 9	190.5
11	1-1/8"	2-3/4"	26035 0	299.5
12	1-1/4"	3"	26038 1	399
14	1-1/2"	3-1/2"	26041 1	662.5

SHOULDER PATTERN – ZINC

Shoulder Pattern No.	Bolt Diameter N.C.	Standard Shank Length	Part No.	Weight Per 100
21	1/4"	1"	26050 3	6
22	5/16"	1-1/8"	26053 4	10.5
23	3/8"	1-1/4"	26056 5	16
24	7/16"	1-3/8"	26059 6	26.5
25	1/2"	1-1/2"	26062 6	38
26	9/16"	1-5/8"	26065 7	49
27	5/8"	1-3/4"	26068 8	73.5
28	3/4"	2"	26071 8	99.5
29	7/8"	2-1/4"	26074 9	172.5
30	1"	2-1/2"	26077 0	235
31	1-1/8"	2-3/4"	26080 0	342.5
32	1-1/4"	3"	26083 1	462.5
34	1-1/2"	3-1/2"	26086 2	752.5



HOT GALVANIZED

PLAIN PATTERN – GALVANIZED

Plain Pattern No.	Bolt Diameter N.C.	Standard Shank Length	Part No.	Weight Per 100
1	1/4"	1"	26105 0	5
2	5/16"	1-1/8"	26108 1	10
3	3/8"	1-1/4"	26111 1	15.5
4	7/16"	1-3/8"	26114 2	20.5
5	1/2"	1-1/2"	26117 3	33
6	9/16"	1-5/8"	26120 3	44.5
7	5/8"	1-3/4"	26123 4	64
8	3/4"	2"	26126 5	90.5
9	7/8"	2-1/4"	26129 6	135
10	1"	2-1/2"	26132 6	190.5
11	1-1/8"	2-3/4"	26135 7	299.5
12	1-1/4"	3"	26138 8	399
14	1-1/2"	3-1/2"	26141 8	662.5

SHOULDER PATTERN – GALVANIZED

Shoulder Pattern No.	Bolt Diameter N.C.	Standard Shank Length	Part No.	Weight Per 100
21	1/4"	1"	26155 5	6
22	5/16"	1-1/8"	26158 6	10.5
23	3/8"	1-1/4"	26161 6	16
24	7/16"	1-3/8"	26164 7	26.5
25	1/2"	1-1/2"	26167 8	38
26	9/16"	1-5/8"	26170 8	49
27	5/8"	1-3/4"	26173 9	73.5
28	3/4"	2"	26176 0	99.5
29	7/8"	2-1/4"	26179 1	172.5
30	1"	2-1/2"	26182 1	235
31	1-1/8"	2-3/4"	26185 2	342.5
32	1-1/4"	3"	26188 3	462.5
34	1-1/2"	3-1/2"	26191 3	752.5

MACHINERY EYE BOLTS



Variation in quantity: on special items we reserve the right to a maximum 10% variation for allowances in manufacture.

- Meets or exceeds all requirements of ASME B30.26 including identification, ductility, design factor, proof load and temperature requirements.
- Material traceability available through Product Identification Code (PIC) System



SPECIAL SHANK LENGTHS PLAIN PATTERN

Bolt Diameter N.C.	Special Shank Length	Threaded		Blank	
		Part No.	Weight Per 100	Part No.	Weight Per 100
1/4"	2"	11608 4	6	11008 2	8
1/4"	3"	11615 2	10	11011 2	14
5/16"	2"	11628 2	12	11028 0	14
5/16"	3"	11631 2	14	11031 0	16
5/16"	4"	11634 3	14	11034 1	18
3/8"	2"	11648 0	16	11048 8	18
3/8"	3"	11651 0	18	11051 8	23
3/8"	4"	11654 1	22	11054 9	24
3/8"	4-1/2"	11657 2	22	11057 0	26
7/16"	2"	11668 8	22	11068 6	24
7/16"	3"	11671 8	26	11071 6	30
7/16"	4"	11674 9	30	11074 7	34
7/16"	4-1/2"	11675 6	30	11077 8	36
1/2"	2"	11688 6	32	11088 4	34
1/2"	3"	11691 6	38	11091 4	42
1/2"	4"	11694 7	42	11094 5	48
1/2"	4-1/2"	11697 8	42	11097 6	50
9/16"	2"	11708 1	48	11108 9	52
9/16"	3"	11711 1	54	11111 9	60
9/16"	4"	11714 2	60	11114 0	68
9/16"	4-1/2"	11717 3	60	11117 1	68
5/8"	2"	11728 9	62	11128 7	68
5/8"	3"	11731 9	70	11131 7	74
5/8"	4"	11734 0	74	11134 8	86
5/8"	4-1/2"	11737 1	76	11137 9	90
3/4"	3"	11751 7	96	11151 5	120
3/4"	4"	11754 8	104	11154 6	126
3/4"	4-1/2"	11757 9	108	11157 7	144
3/4"	5"	11760 9	132	11160 7	154
7/8"	3"	11771 5	188	11171 3	196
7/8"	4"	11774 6	202	11174 4	218
7/8"	4-1/2"	11777 7	210	11177 5	224
7/8"	5"	11780 7	218	11180 5	230
1"	3"	11791 3	210	11191 1	232
1"	4"	11794 4	230	11194 2	254
1"	4-1/2"	11797 5	236	11197 3	264
1"	5"	11800 2	254	11200 0	276



SPECIAL SHANK LENGTHS SHOULDER PATTERN

Bolt Diameter N.C.	Special Shank Length	Threaded		Blank	
		Part No.	Weight Per 100	Part No.	Weight Per 100
1/4"	2"	12808 7	8	12208 5	10
1/4"	3"	12811 7	10	12211 5	12
5/16"	2"	12828 5	12	12228 3	14
5/16"	3"	12831 5	14	12231 3	16
5/16"	4"	12834 6	16	12234 4	18
3/8"	2"	12848 3	20	12248 1	22
3/8"	3"	12851 3	22	12251 1	24
3/8"	4"	12854 4	24	12254 2	28
3/8"	4-1/2"	12857 5	26	12257 3	28
7/16"	2"	12868 1	26	12268 9	30
7/16"	3"	12871 1	30	12271 9	32
7/16"	4"	12874 2	34	12274 0	36
7/16"	4-1/2"	12877 3	36	12277 1	38
1/2"	2"	12888 9	40	12288 7	42
1/2"	3"	12891 9	44	12291 7	46
1/2"	4"	12894 0	46	12294 8	50
1/2"	4-1/2"	12897 1	48	12297 9	52
9/16"	2"	12908 4	48	12308 2	52
9/16"	3"	12911 4	52	12311 2	58
9/16"	4"	12914 5	58	12314 3	60
9/16"	4-1/2"	12917 6	60	12317 4	68
5/8"	2"	12928 2	74	12328 0	80
5/8"	3"	12931 2	82	12331 0	86
5/8"	4"	12934 3	90	12334 1	102
5/8"	4-1/2"	12937 4	92	12337 2	104
3/4"	3"	12951 0	116	12351 8	126
3/4"	4"	12954 1	130	12354 9	140
3/4"	4-1/2"	12957 2	132	12357 0	146
3/4"	5"	12960 2	138	12360 0	154
7/8"	3"	12971 8	186	12371 6	198
7/8"	4"	12974 9	202	12374 7	218
7/8"	4-1/2"	12977 0	208	12377 8	226
7/8"	5"	12980 0	216	12380 8	232
1"	3"	12991 6	254	12391 4	270
1"	4"	12994 7	266	12394 5	290
1"	4-1/2"	12997 8	280	12397 6	304
1"	5"	13000 4	290	12400 3	318

See page 18 for specifications and dimensions.
Additional special shank lengths available upon request.



METRIC MACHINERY EYE BOLTS

Dimensions in Millimeters – Some Sizes Available in Stainless Steel on a Special Basis.

FORGED • CARBON STEEL
SELF-COLORED • SHOULDER PATTERN



METRIC SELF-COLORED

Part No.	Metric Size	A Thread Size	B Shank Length, mm	C I.D. Eye, mm	Approx. Wt. Per 100 Pcs. in Lbs.	Working Load Limit in Kgs.	Working Load Limit in Lbs.
13805 5	M6	M6 x 1.0	25.4	19	5	210	462
13825 3	M7	M7 x 1.0	28.5	22	10	370	814
13845 1	M8	M8 x 1.25	31.7	25	17	450	992
13865 9	M10	M10 x 1.5	35.0	28	27	740	1,628
13885 7	M12	M12 x 1.75	38.0	30	36	1,030	2,266
13905 2	M14	M14 x 2.0	44.5	35	71	1,600	3,520
13925 0	M16	M16 x 2.0	44.5	35	74	1,600	3,520
13948 9	M18	M18 x 2.5	51.0	38	99	2,140	4,708
13968 7	M20	M20 x 2.5	57.0	43	158	2,860	6,292
13988 5	M24	M24 x 3.0	63.5	46	227	3,850	8,470
14008 9	M27	M27 x 3.0	70.0	51	341	5,200	11,440
14031 7	M30	M30 x 3.5	76.0	55	460	6,400	14,080
14051 5	M36	M36 x 4.0	89.0	63	734	8,970	19,734

METRIC HOT GALVANIZED

Part No.	Metric Size	A Thread Size	B Shank Length, mm	C I.D. Eye, mm	Approx. Wt. Per 100 Pcs. in Lbs.	Working Load Limit in Kgs.	Working Load Limit in Lbs.
12500 0	M6	M6 x 1.0	25.4	19	5	210	462
12501 7	M7	M7 x 1.0	28.5	22	10	370	814
12502 4	M8	M8 x 1.25	31.7	25	17	450	992
12503 1	M10	M10 x 1.5	35.0	28	27	740	1,628
12504 8	M12	M12 x 1.75	38.0	30	36	1,030	2,266
12505 5	M14	M14 x 2.0	44.5	35	71	1,600	3,520
12506 2	M16	M16 x 2.0	44.5	35	74	1,600	3,520
12507 9	M18	M18 x 2.5	51.0	38	99	2,140	4,708
12508 6	M20	M20 x 2.5	57.0	43	158	2,860	6,292
12509 3	M24	M24 x 3.0	63.5	46	227	3,850	8,470
12510 9	M27	M27 x 3.0	70.0	51	341	5,200	11,440
12511 6	M30	M30 x 3.5	76.0	55	460	6,400	14,080
12512 3	M36	M36 x 4.0	89.0	63	734	8,970	19,734

METRIC SPECIAL SHANK LENGTHS — SELF-COLORED

Part No.	Metric Size	A Thread Size	B Shank Length, mm	C I.D. Eye, mm	Approx. Wt. Per 100 Pcs. in Lbs.	Working Load Limit in Kgs.	Working Load Limit in Lbs.
13850 5	M8	M8 x 1.25	76.0	25	19	450	992
13895 6	M12	M12 x 1.75	76.0	30	45	1,030	2,266
13936 6	M16	M16 x 2.0	76.0	35	85	1,600	3,520
13958 8	M18	M18 x 2.5	76.0	38	113	2,140	4,708

ALLOY STEEL SWIVEL HOIST RINGS



Swivel Hoist Rings have full swivel and pivot action and are the ideal product for angular lift applications. They are alloy steel with a black oxide finish and they adhere to the same rigid quality standards that have been a part of Chicago Hardware's proud tradition since 1912. Individually proof tested and magnetic particle inspected. From 800 to 24,000 lb load capacities (Rated at 5:1 design factor).

Part No.	Thread Size (A)	Working Load Limit	Thread Length (C)	B	D	E	F	G	H	Torque
86004 8	5/16"-18	800	9/16"	2.67"	0.75"	0.43"	0.38"	1.84"	1-1/4"	7
86007 9	3/8"-16	1000	9/16"	2.67"	0.75"	0.43"	0.38"	1.84"	1-1/4"	12
86013 0	1/2"-13	2500	3/4"	4.78"	1.5"	0.88"	0.75"	3.52"	2-3/8"	28
86016 1	1/2"-13	2500	1"	4.78"	1.5"	0.88"	0.75"	3.52"	2-3/8"	28
86019 2	1/2"-13	2500	1-1/4"	4.78"	1.5"	0.88"	0.75"	3.52"	2-3/8"	28
86022 2	5/8"-11	4000	1"	4.78"	1.5"	0.88"	0.75"	3.52"	2-1/4"	60
86025 3	5/8"-11	4000	1-1/4"	4.78"	1.5"	0.88"	0.75"	3.52"	2-1/4"	60
86028 4	3/4"-10	5000	1"	4.78"	1.5"	0.88"	0.75"	3.52"	2-1/8"	100
86031 4	3/4"-10	5000	1-1/2"	4.78"	1.5"	0.88"	0.75"	3.52"	2-1/8"	100
86034 5	3/4"-10	7000	1"	6.52"	2.31"	1.4"	1"	5.14"	2-15/16"	100
86037 6	3/4"-10	7000	1-1/2"	6.52"	2.31"	1.4"	1"	5.14"	2-15/16"	100
86043 7	7/8"-9	8000	1-1/4"	6.52"	2.31"	1.4"	1"	5.14"	2-13/16"	160
86046 8	1"-8	10000	1-1/4"	6.52"	2.31"	1.4"	1"	5.14"	2-11/16"	230
86049 9	1"-8	10000	1-1/2"	6.52"	2.31"	1.4"	1"	5.14"	2-11/16"	230
86052 9	1"-8	10000	2-1/4"	6.52"	2.31"	1.4"	1"	5.14"	2-11/16"	230
86055 0	1-1/4"-7	15000	1-7/8"	8.73"	3.19"	1.75"	1.25"	6.5"	4-1/4"	470
86061 1	1-1/2"-6	24000	2-3/4"	12.47"	4.19"	2.25"	1.75"	8.55"	6-1/2"	800

- Meets or exceeds all requirements of ASME B30.26 including identification, ductility, design factor, proof load and temperature requirements.
- Material traceability available through Product Identification Code (PIC) System

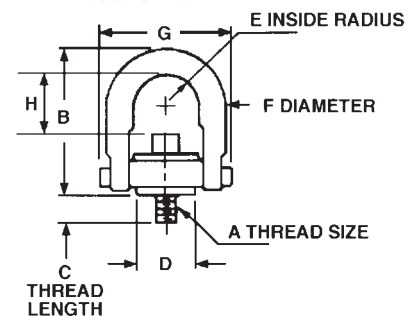

WARNING: DO NOT EXCEED SAFE WORK LOAD

DROP FORGED LIFTING EYES

Drop forged from C-1035 steel, heat treated. Available blank or threaded. Self-colored finish is standard; hot galvanized or other finishes supplied on a special basis. Used in lifting applications where larger eyes are required. When ordering prefix stock number with letter "B" (blank) or "T" (threaded) as required. Loads are based on a design factor of 5 to 1. Working loading limits for lifting eyes are based on a straight vertical lift in a gradually increasing manner, and should never be used for angular lifts.

LIFTING EYES – SELF-COLORED

Stock Number	Bail Size	Blank Part No.	Threaded Part No.	Threaded Working Load Limit
C-186	1/4"	15005 7	15505 2	860
C-187	5/16"	15010 1	15510 6	1260
C-185	3/8"	15015 6	15515 1	2200
C-181	1/2"	15020 0	15520 5	3600
C-184	5/8"	15025 5	15525 0	5200
C-188	3/4"	15030 9	15530 4	7000

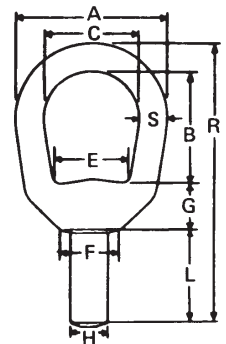

Stock Number	Shank		Dimensions - Inches								Thread Length	Weight Per 100	
	H	L	A	C	B	E	F	G	S	R		Blank	Threaded
C-186	5/16"	1"	1-1/4"	3/4"	1-1/16"	19/32"	1/2"	3/8"	1/4"	2-11/16"	7/8"	12	11
C-187	3/8"	1-1/8"	1-5/8"	1"	1-1/4"	3/4"	9/16"	1/2"	5/16"	3-3/16"	1"	22	22
C-185	1/2"	1-1/2"	2"	1-1/4"	1-1/2"	1"	13/16"	5/8"	3/8"	4"	1-3/8"	41	38
C-181	5/8"	1-3/4"	2-1/2"	1-1/2"	2"	1-3/16"	1"	11/16"	1/2"	4-15/16"	1-5/8"	81	74
C-184	3/4"	1-7/8"	3"	1-3/4"	2-3/8"	1-3/8"	1-1/8"	7/8"	5/8"	5-3/4"	1-3/4"	139	129
C-188	7/8"	2"	3-1/2"	2"	2-5/8"	1-5/8"	1-5/16"	15/16"	3/4"	6-5/16"	1-7/8"	222	214



DROP FORGED HOOKS

Hooks are drop forged steel and heat treated. Latch, spring, machine screw and nut are stainless steel. These hooks are also available without the latch kit.

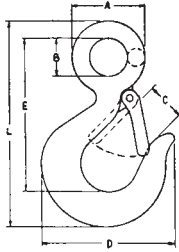

NOTE:
Latch Kit Screw & Nuts
are imported



Stock No.	Working Load Limit in Tons	Weight Per 100	Dimensions - Inches						Safety Hooks		Eye Hooks		Latch Kits
			A	B	C	D	E	L	Self-Colored Part No.	Galv. Part No.	Self-Colored Part No.	Galv. Part No.	Stainless Steel Part No. Per Set
22	3/4	59.5	1-1/2"	3/4"	13/16"	2-7/8"	3-1/4"	4-3/8"	22605 9	22655 4	22705 6	22755 1	25105 1
23	1	87	1-3/4"	7/8"	29/32"	3-3/16"	3-23/32"	4-31/32"	22610 3	22660 8	22710 0	22760 5	25105 1
24	1-1/2	113.5	2"	1"	27/32"	3-15/32"	4"	5-13/32"	22615 8	22665 3	22715 5	22765 0	25110 5
25	2	169.5	2-1/4"	1-1/8"	1-1/8"	4-1/16"	4-5/8"	6-5/16"	22620 2	22670 7	22720 9	22770 4	25115 0
26	3	258.5	2-1/2"	1-1/4"	1-5/32"	4-1/2"	4-31/32"	6-27/32"	22625 7	22675 2	22725 4	22775 9	25115 0

DROP FORGED HIGH-TEST CHAIN HOOKS



Made for use on High-Test Chain. All hooks are heat treated. Also can be used on BBB and proof coil. High Test stamped on every hook. Available Self-Colored and Zinc Plated.



CLEVIS GRAB HOOKS / DROP FORGED HIGH-TEST

Chain Size	Working Load Limit in Pounds	A	B	C	D	E	F	Weight Per 100 in Pounds	Self-Colored	Zinc Plated
									Part No.	Part No.
1/4"	2600	5/16"	1-15/16"	3/8"	3-3/8"	5/16"	2"	31.5	23705 5	23805 2
5/16"	4000	3/8"	2-1/4"	7/16"	3-15/16"	3/8"	2-3/8"	58.5	23710 9	23810 6
3/8"	5400	7/16"	2-11/16"	1/2"	4-1/2"	7/16"	2-11/16"	93.5	23715 4	23815 1
7/16"	7200	1/2"	3"	9/16"	5-1/32"	1/2"	3"	147	23720 8	23820 5
1/2"	9200	19/32"	3-5/16"	21/32"	5-5/8"	9/16"	3-23/64"	184	23725 3	23825 0
5/8"	11500	3/4"	4-1/4"	25/32"	6-7/8"	11/16"	4"	370	23730 7	23830 4
3/4"	16200	7/8"	5-1/4"	15/16"	8"	3/4"	4-19/32"	604	23735 2	23835 9

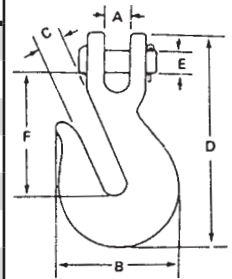

DROP FORGED SAFETY SNAP HOOKS

Hooks are drop forged steel and heat treated. Latch, spring, machine screw and nut are stainless steel. Vertical loads are based on a design factor of 5 to 1.

HEAT TREATED SAFETY SNAP HOOKS

Hook Size	Working Load Limit in Pounds	I.D. Eye	Throat Opening	Overall Length	Est. Wt. Per 100	Self-Colored	Galvanized
						Part No.	Part No.
7/16"	750 Lbs.	3/4"	3/4"	3-15/16"	28.8 Lbs.	22905 0	22955 5
9/16"	1000 Lbs.	1-1/8"	13/16"	4-3/4"	57.6 Lbs.	22910 4	22960 9



NOTE:
Latch Kit Screw & Nuts
are imported

DROP FORGED SWIVELS



Drop forged steel – all threaded components are heat treated. All swivels are hot galvanized. Jaws (jaw and eye type) supplied with flat head pin and cotter. Vertical loads are based on a design factor of 5 to 1.

EYE AND EYE

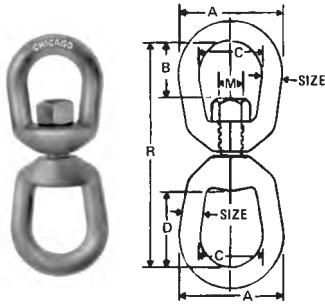

Part No.	Dimensions – Inches							Working Load Limit (Tons)	Weight Per 100
	Size	A	B	C	D	M	R		
21505 3	1/4"	1-1/4"	5/8"	3/4"	1-1/16"	5/16"	2-15/16"	.43	20.2
21510 7	5/16"	1-5/8"	3/4"	1"	1-1/4"	3/8"	3-9/16"	.63	36.5
21515 2	3/8"	2"	7/8"	1-1/4"	1-1/2"	1/2"	4-5/16"	1.1	70
21520 6	1/2"	2-1/2"	1-3/16"	1-1/2"	2"	5/8"	5-3/8"	1.8	141
21525 1	5/8"	3"	1-1/2"	1-3/4"	2-3/8"	3/4"	6-5/8"	2.6	249.5
21530 5	3/4"	3-1/2"	1-5/8"	2"	2-5/8"	7/8"	7-3/8"	3.5	413.5

CHAIN

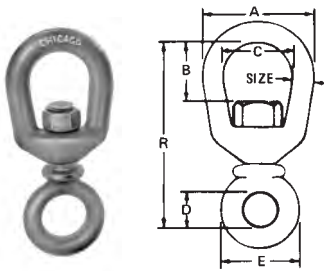

Part No.	Dimensions – Inches							Working Load Limit (Tons)	Weight Per 100
	Size	A	B	C	D	E	R		
21705 7	1/4"	1-1/4"	5/8"	3/4"	1/2"	1"	2-7/16"	.26	14
21710 1	5/16"	1-5/8"	3/4"	1"	5/8"	1-1/4"	2-15/16"	.46	27
21715 6	3/8"	2"	7/8"	1-1/4"	3/4"	1-1/2"	3-9/16"	.62	47.5
21720 0	1/2"	2-1/2"	1-1/4"	1-1/2"	1"	2"	4-9/16"	1.1	100
21725 5	5/8"	3"	1-9/16"	1-3/4"	1-1/4"	2-5/16"	5-5/8"	1.6	169
21730 9	3/4"	3-1/2"	1-3/4"	2"	1-1/2"	2-3/4"	6-1/8"	2.0	268

JAW AND EYE

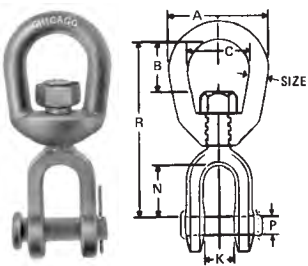

Part No.	Dimensions – Inches								Working Load Limit (Tons)	Weight Per 100
	Size	A	B	C	N	K	P	R		
21605 0	1/4"	1-1/4"	5/8"	3/4"	25/32"	15/32"	1/4"	2-1/2"	.43	18.5
21610 4	5/16"	1-5/8"	3/4"	1"	27/32"	1/2"	5/16"	2-7/8"	.63	35
21615 9	3/8"	2"	7/8"	1-1/4"	1-1/16"	5/8"	7/16"	3-1/2"	1.1	67.5
21620 3	1/2"	2-1/2"	1-1/4"	1-1/2"	1-15/32"	7/8"	1/2"	4-9/16"	1.8	131
21625 8	5/8"	3"	1-9/16"	1-3/4"	1-17/32"	1"	5/8"	5-5/16"	2.6	240
21630 2	3/4"	3-1/2"	1-3/4"	2"	1-3/4"	1-1/8"	3/4"	6"	3.5	360

SAFETY SWIVEL HOOKS

Drop forged steel. Hook is heat treated. Latch, spring, machine screw and nut are stainless steel.

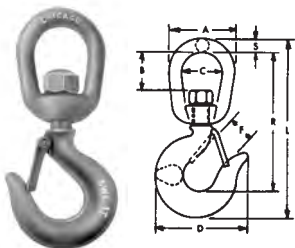

Part No.	Dimensions – Inches								Working Load Limit (Tons)	Weight Per 100
	A	B	C	D	F	L	R	S		
21905 1	2"	15/16"	1-1/4"	2-7/8"	7/8"	5-9/16"	4-15/32"	3/8"	.75	91
21910 5	2-1/2"	1-5/16"	1-1/2"	3-3/16"	31/32"	6-5/8"	5-9/32"	1/2"	1	148





DROP FORGED EYE NUTS

Stock Eye Nuts listed below, other than Blanks, are drilled and tapped standard regardless of finish. Both types drilled only, with special tapping or finish supplied to specification. Loads are based on a design factor of 5 to 1. Blanks are self-colored.

NOTE: Loads shown apply to Eye Nuts only, based on a vertical pull, and not to any connecting bolt or stud.

- Meets or exceeds all requirements of ASME B30.26 including identification, ductility, design factor, proof load and temperature requirements.
- Material traceability available through Product Identification Code (PIC) System

REGULAR EYE NUTS



Regular

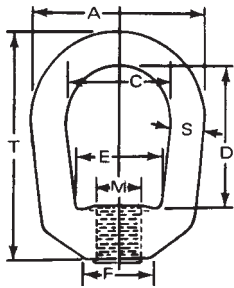

Stock No.	Bail Size	Tap Size	Drilled & Tapped			Blank Part No.
			Self-Colored Part No.	Hot Galvanized Part No.	Working Load Limit (Lbs)	
C-186A	1/4"	1/4"-20	16255 5	16755 5	520	16005 6
C-186B	1/4"	5/16"-18	16260 9	16760 9	840	16010 0
C-187A	5/16"	3/8"-16	16265 4	16765 9	1240	16015 5
C-185B	3/8"	7/16"-14	16270 8	16770 8	1700	16020 9
C-185A	3/8"	1/2"-13	16275 3	16775 8	2240	16025 4
C-181A	1/2"	5/8"-11	16280 7	16780 2	3600	16030 8
C-184A	5/8"	3/4"-10	16285 2	16785 7	5200	16035 3
C-188A	3/4"	7/8"-9	16290 6	16790 1	7200	16040 7
C-188B	3/4"	1"-8	16295 1	16795 6	7200	16045 2

REGULAR EYE NUTS - METRIC

Stock No.	Metric Size	Bail Size	Thread Size	Self-Colored Part No.	Hot Galvanized Part No.	Working Load Limit (Lbs)
C-186A	M6	1/4"	M6 x 1.0	14970 9	14980 8	350
C-186B	M7	1/4"	M7 x 1.0	14971 6	14981 5	500
C-187A	M8	5/16"	M8 x 1.25	14972 3	14982 2	650
C-185B	M10	3/8"	M10 x 1.5	14973 0	14983 9	800
C-185A	M12	3/8"	M12 x 1.75	14974 7	14984 6	1700
C-181A	M16	1/2"	M16 x 2.0	14975 4	14985 3	2500
C-184A	M18	5/8"	M18 x 2.5	14976 1	14986 0	3000
C-188A	M20	3/4"	M20 x 2.5	14977 8	14987 7	3500
C-188B	M24	3/4"	M24 x 3.0	14978 5	14988 4	5000



Some sizes also available in Stainless Steel. See page 42.

SPECIFICATIONS

Stock No.	Tap Sizes		Dimensions - Inches							Drilled & Tapped Wgt. Per 100	Blank Wgt. Per 100
	Std. M	Max. N	A	C	D	E	F	S	T		
C-186A	1/4"-20	3/8"	1-1/4"	3/4"	1-1/16"	19/32"	1/2"	1/4"	1-11/16"	8.2	9
C-186B	5/16"-18	3/8"	1-1/4"	3/4"	1-1/16"	19/32"	1/2"	1/4"	1-11/16"	8	9
C-187A	3/8"-16	7/16"	1-5/8"	1"	1-1/4"	3/4"	9/16"	5/16"	2-1/16"	15.7	16
C-185B	7/16"-14	1/2"	2"	1-1/4"	1-1/2"	1"	13/16"	3/8"	2-1/2"	29.7	31
C-185A	1/2"-13	1/2"	2"	1-1/4"	1-1/2"	1"	13/16"	3/8"	2-1/2"	29.3	31
C-181A	5/8"-11	3/4"	2-1/2"	1-1/2"	2"	1-3/16"	1"	1/2"	3-3/16"	61.5	66
C-184A	3/4"-10	7/8"	3"	1-3/4"	2-3/8"	1-3/8"	1-1/8"	5/8"	3-7/8"	103	112
C-188A	7/8"-9	1"	3-1/2"	2"	2-5/8"	1-5/8"	1-5/16"	3/4"	4-5/16"	163	183
C-188B	1"-8	1"	3-1/2"	2"	2-5/8"	1-5/8"	1-5/16"	3/4"	4-5/16"	161	183

DROP FORGED HEAVY DUTY EYE NUTS



Stock Eye Nuts listed below, other than Blanks, are drilled and tapped standard regardless of finish. Both types drilled only, with special tapping or finish supplied to specification. Loads are based on a design factor of 5 to 1. Self-colored finish is standard.

NOTE: Loads shown apply to Eye Nuts only, based on a vertical pull, and not to any connecting bolt or stud.



SELF-COLORED – BLANK OR DRILLED AND TAPPED

Stock No.	Bail Size	Drilled & Tapped			Blank Part No.
		Tap Size	Part No.	Working Load Limit (Lbs)	
100	5/16"	3/8"-16	17255 4	1800	17005 5
101	7/16"	1/2"-13	17260 8	3600	17010 9
102	9/16"	5/8"-11	17265 3	5800	17015 4
103	3/4"	3/4"-10	17270 7	10600	17020 8
104	7/8"	7/8"-9	17275 2	14400	17025 3
105	1"	1"-8	17280 6	18800	17030 7
105A	1"	1-1/8"-7	17285 1	22600	17035 2
106	1-1/4"	1-1/4"-7	17290 5	29400	17040 6
107	1-3/8"	1-1/2"-6	17295 0	35600	17045 1



Blank



Drilled & Tapped

METRIC HEAVY DUTY DROP FORGED EYE NUTS

Stock No.	Metric Size	Bail Size	Thread Size	Part No.	Working Load Limit (Lbs)
100	M8	5/16"	M8 x 1.25	17155 7	1100
101	M12	7/16"	M12 x 1.75	17160 1	2300
102	M16	9/16"	M16 x 2.0	17165 6	3700
103	M18	3/4"	M18 x 2.5	17170 0	6000
104	M20	7/8"	M20 x 2.5	17175 5	7600
105	M24	1"	M24 x 3.0	17180 9	11000
106	M30	1-1/4"	M30 x 3.5	17185 4	14000
107	M36	1-3/8"	M36 x 4.0	17190 8	19000

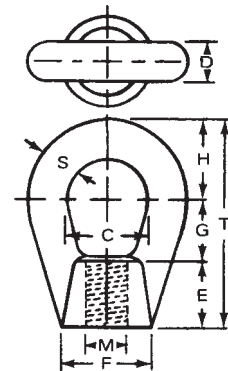

SPECIFICATIONS

Stock No.	Dimensions - Inches									Drilled & Tapped Wgt. Per 100	Blank Wgt. Per 100
	C	S	D	M	F	E	G	H	T		
100	7/8"	5/16"	5/16"	3/8-16"	3/4"	3/4"	3/4"	3/4"	2-1/4"	15	16
101	1-1/8"	7/16"	7/16"	1/2-13"	1"	1"	1"	1"	3"	37.5	43
102	1-3/8"	9/16"	9/16"	5/8-11"	1-1/4"	1-1/4"	1-1/4"	1-1/4"	3-3/4"	82.5	94
103	1-1/2"	3/4"	3/4"	3/4-10"	1-3/4"	1-1/4"	1-1/8"	1-1/2"	3-7/8"	145	160
104	1-5/8"	7/8"	7/8"	7/8-9"	2"	1-1/4"	1"	1-11/16"	3-15/16"	202.5	210
105	1-3/4"	1"	1"	1-8"	2-1/4"	1-5/8"	1-1/4"	1-7/8"	4-3/4"	327.5	340
105A	1-3/4"	1"	1"	1-1/8-7"	2-1/4"	1-5/8"	1-1/4"	1-7/8"	4-3/4"	297	340
106	2"	1-1/4"	1-1/4"	1-1/4-7"	2-7/8"	1-7/8"	1-3/8"	2-1/4"	5-1/2"	550	623
107	2-1/2"	1-3/8"	1-3/8"	1-1/2-6"	3-1/8"	2-1/8"	1-3/4"	2-5/8"	6-1/2"	807.5	919



DROP FORGED BLANK ROD ENDS

Drop forged. Listed diameters and lengths carried in stock blank, self-colored. Drilling, threading, other machining and plating furnished to specification.

NOTE: Average properties of 1035 natural hot rolled steel 75/85,000 lbs. P.S.I. tensile, 40/55,000 lbs. P.S.I. yield.

DROP FORGED BLANK ROD ENDS

Stock No.	Part No.	Dimensions - Inches				Weight Per 100
		Shank Diameter (B)	Boss Diameter (C)	Boss Thickness (F)	*Length (A) in Inches	
C-134	18005 4	1/4"	1/2"	9/32"	3"	6.1
C-134-A	18010 8	1/4"	1/2"	9/32"	6"	11
C-135	18015 3	5/16"	5/8"	11/32"	3"	9.5
C-135-A	18020 7	5/16"	5/8"	11/32"	6"	18
C-163-A	18025 2	3/8"	11/16"	3/8"	2-1/8"	12
C-162	18030 6	3/8"	3/4"	3/8"	2-1/2"	12.5
C-217	18035 1	3/8"	3/4"	7/16"	3"	14
C-136	18040 5	3/8"	3/4"	7/16"	6"	25.5
C-137	18045 0	7/16"	7/8"	1/2"	6"	35
C-245	18050 4	1/2"	15/16"	9/16"	1-3/4"	22
C-163	18055 9	1/2"	15/16"	9/16"	3-1/8"	27.5
C-212	18060 3	1/2"	1"	9/16"	3-1/2"	30
C-138	18065 8	1/2"	1"	9/16"	6"	47
C-195	18070 2	1/2"	1"	9/16"	10"	70
C-189	18075 7	5/8"	1-1/4"	11/16"	3"	45.5
C-303	18080 1	5/8"	1-3/16"	5/8"	3-1/2"	48
C-139	18085 6	5/8"	1-1/4"	11/16"	6"	77.5
C-172	18090 0	5/8"	1-1/4"	11/16"	8"	92
C-196	18095 5	5/8"	1-1/4"	11/16"	10"	119
C-216	18100 6	3/4"	1-1/2"	13/16"	3-1/2"	82
C-140	18105 1	3/4"	1-1/2"	13/16"	6"	112
C-197	18110 5	3/4"	1-1/2"	13/16"	10"	163.5
C-141	18115 0	7/8"	1-3/4"	15/16"	6"	164
C-211	18120 4	7/8"	1-3/4"	15/16"	12"	377
C-142	18125 9	1"	2"	1-1/16"	6"	216
C-142-A	18130 3	1"	2"	1-1/16"	12"	354
C-282	18135 8	1-1/4"	2-1/2"	1-5/16"	12"	595

Some sizes also available in Stainless Steel. See page 40.



MACHINED ROD ENDS

Use graphic below

Dimensions		Quantity
A		MATERIAL SPEC
B		FINISH
C		HEAT TREAT
F		
G		
T		

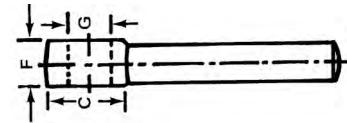
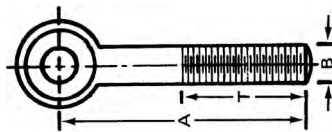

DROP FORGED PAD EYES

DROP FORGED PAD EYES

Stock No.	Part No.	Dimensions - Inches					Weight Per 100 in Lbs.
		Eye		Shoulder		*Overall Height	
		I.D.	O.D.	O.D.	*Thickness		
C-351	22005 7	1/4"	5/8"	5/8"	3/32"	3/4"	3.3
C-350	22010 1	3/4"	1-1/2"	1-1/16"	3/16"	1-5/8"	18.6
C-155	22015 6	1-3/16"	2-1/16"	1-11/16"	3/16"	2-3/8"	49
C-169	22020 0	1-1/4"	2-3/8"	2"	3/16"	2-7/8"	81



- Forged from carbon steel suitable for welding.
- Supplied with self-colored finish.
- Reference American Welding Society specifications for proper welding procedures.
- *Not including draft.

BLACK OXIDE MACHINED ROD ENDS



Drop forged. Listed diameters, lengths, thread lengths and hole sizes carried in stock. Drilling, threading, other machining and plating furnished to specification.

NOTE: Average properties of 1035 natural hot rolled steel 75/85,000 lbs. P.S.I. tensile, 40/55,000 lbs. P.S.I. yield.

Part No.	Thread Pitch	Dimensions – Inches					Weight Per 100
		Length in Inches (A)*	Thread Length (T)	Hole I.D. (G)	Boss Diameter (C)	Boss Thickness (F)	
18205 8	1/4"-20	2"	3/4"	3/16"	1/2"	9/32"	4
18206 5	1/4"-20	2"	3/4"	1/4"	1/2"	9/32"	4
11656 5	1/4"-20	3"	3/4"	3/16"	1/2"	9/32"	4
18207 2	1/4"-20	3"	3/4"	1/4"	1/2"	9/32"	4
11525 4	1/4"-20	4"	3/4"	3/16"	1/2"	9/32"	5
18208 9	1/4"-20	4"	3/4"	1/4"	1/2"	9/32"	5
11575 9	5/16"-18	3"	1-1/2"	1/4"	5/8"	11/32"	8
18210 2	5/16"-18	3"	1-1/2"	5/16"	5/8"	11/32"	8
11695 4	5/16"-18	4"	2"	1/4"	5/8"	11/32"	9
11627 5	5/16"-18	4"	2"	5/16"	5/8"	11/32"	9
18215 7	3/8"-16	3"	1-1/2"	5/16"	3/4"	7/16"	12
18220 1	3/8"-16	3"	1-1/2"	3/8"	3/4"	7/16"	12
18225 6	3/8"-16	3-3/4"	2"	3/8"	3/4"	7/16"	14
18230 0	3/8"-16	4"	1-1/2"	3/8"	3/4"	7/16"	16
18235 5	3/8"-16	5"	2-1/2"	3/8"	3/4"	7/16"	18
18245 4	1/2"-13	3-3/4"	1-1/2"	3/8"	1"	9/16"	29
18250 8	1/2"-13	4"	1-1/2"	3/8"	1"	9/16"	30
18251 5	1/2"-13	4"	1-1/2"	1/2"	1"	9/16"	30
18240 9	1/2"-13	5"	1-1/2"	3/8"	1"	9/16"	36
18255 3	1/2"-13	5"	2"	3/8"	1"	9/16"	36
11554 4	1/2"-13	6"	1-1/2"	3/8"	1"	9/16"	42
18260 7	5/8"-11	4-1/2"	2"	5/8"	1-1/4"	11/16"	50
18265 2	5/8"-11	5"	1-3/4"	5/8"	1-1/4"	11/16"	55
11598 8	5/8"-11	6"	1-3/4"	5/8"	1-1/4"	11/16"	63
18270 6	5/8"-11	6"	2-1/2"	5/8"	1-1/4"	11/16"	63
11580 3	5/8"-11	7"	1-3/4"	5/8"	1-1/4"	11/16"	70
11700 5	5/8"-11	8"	1-3/4"	5/8"	1-1/4"	11/16"	78
18280 5	3/4"-10	4-1/2"	2"	3/4"	1-1/2"	13/16"	77
11661 9	3/4"-10	5"	1-3/4"	5/8"	1-1/2"	13/16"	83
11522 3	3/4"-10	6"	1-3/4"	5/8"	1-1/2"	13/16"	95
18275 1	3/4"-10	6"	2-1/2"	3/4"	1-1/2"	13/16"	95
11701 2	3/4"-10	7"	1-3/4"	5/8"	1-1/2"	13/16"	107
11517 9	3/4"-10	8"	1-3/4"	5/8"	1-1/2"	13/16"	119
11688 8	7/8"-9	6"	2"	3/4"	1-3/4"	15/16"	146
18290 4	7/8"-9	6"	2"	7/8"	1-3/4"	15/16"	146
11702 9	7/8"-9	12"	4"	3/4"	1-3/4"	15/16"	250
11609 1	1"-8	6"	2"	7/8"	2"	1-1/16"	185
18300 0	1"-8	6"	2"	1"	2"	1-1/16"	185
11672 5	1"-8	12"	4"	7/8"	2"	1-1/16"	325
11670 1	1-1/4"-7	6"	2-1/2"	1-1/8"	2-1/2"	1-5/16"	315
11632 9	1-1/4"-7	12"	4-1/2"	1-1/8"	2-1/2"	1-5/16"	545

* Measured from center of boss

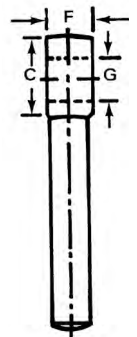
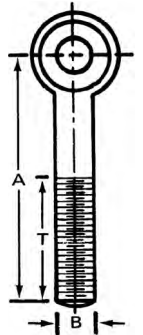



DROP FORGED YOKE ENDS

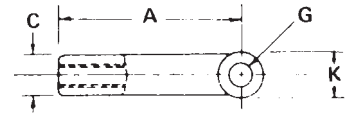
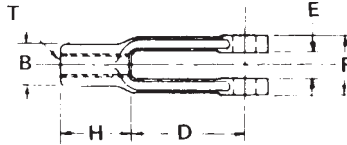

ADJUSTABLE, SELF-COLORED DROP FORGED YOKE ENDS – NATIONAL FINE THREAD

Stock No.	Part No.	"T" Tap Size	Dimensions in Inches – Machined									Est. Wt. Per 100 Pcs.
			A	B	C	D	E	F	G	H	K	
51	19505 8	1/4"-28	2"	7/16"	7/16"	1-1/4"	9/32"	5/8"	1/4"	3/4"	1/2"	7.5 Lbs.
52	19510 2	5/16"-24	2-1/4"	1/2"	1/2"	1-7/16"	11/32"	3/4"	5/16"	13/16"	19/32"	10.7 Lbs.
53	19515 7	3/8"-24	2-1/2"	5/8"	5/8"	1-5/8"	7/16"	7/8"	3/8"	7/8"	11/16"	18 Lbs.
54	19520 1	7/16"-20	2-7/8"	23/32"	23/32"	1-7/8"	1/2"	1"	7/16"	1"	13/16"	24 Lbs.
55	19525 6	1/2"-20	3"	13/16"	13/16"	1-7/8"	9/16"	1-1/8"	1/2"	1-1/8"	15/16"	32 Lbs.
56	19530 0	5/8"-18	4-15/16"	1-1/16"	1-1/16"	3-11/16"	11/16"	1-3/8"	5/8"	1-1/4"	1-3/16"	86 Lbs.
57	19535 5	3/4"-16	6-1/16"	1-1/4"	1-1/4"	4-9/16"	13/16"	1-5/8"	3/4"	1-1/2"	1-7/16"	131 Lbs.

ADJUSTABLE, SELF-COLORED DROP FORGED YOKE ENDS – NATIONAL COARSE THREAD

Stock No.	Part No.	"T" Tap Size	Dimensions in Inches – Machined									Est. Wt. Per 100 Pcs.
			A	B	C	D	E	F	G	H	K	
51C	19540 9	1/4"-20	2"	7/16"	7/16"	1-1/4"	9/32"	5/8"	1/4"	3/4"	1/2"	7.5 Lbs.
52C	19545 4	5/16"-18	2-1/4"	1/2"	1/2"	1-7/16"	11/32"	3/4"	5/16"	13/16"	19/32"	10.7 Lbs.
53C	19550 8	3/8"-16	2-1/2"	5/8"	5/8"	1-5/8"	7/16"	7/8"	3/8"	7/8"	11/16"	18 Lbs.
55C	19555 3	1/2"-13	3"	13/16"	13/16"	1-7/8"	9/16"	1-1/8"	1/2"	1-1/8"	15/16"	32 Lbs.

SELF-COLORED SAE CLEVIS PINS FOR YOKE ENDS



Part No.	Shank Diameter	Dimensions in Inches – Machined						Weight Per 100 in Lbs.
		Lengths		Head		Hole		
		Overall	Under Head	O.D.	Thickness	I.D.	*Center	
19305 4	1/4"	55/64"	49/64"	3/8"	3/32"	5/64"	43/64"	1.3
19310 8	5/16"	1-1/32"	15/16"	7/16"	3/32"	7/64"	13/16"	2.3
19315 3	3/8"	1-3/16"	1-1/16"	1/2"	1/8"	7/64"	15/16"	3.7
19320 7	7/16"	1-11/32"	1-3/16"	9/16"	5/32"	7/64"	1-1/16"	5.9
19330 6	1/2"	1-33/64"	1-23/64"	5/8"	5/32"	9/64"	1-13/64"	8.6
19335 1	5/8"	1-13/16"	1-39/64"	13/16"	13/64"	9/64"	1-29/64"	16.2
19340 5	3/4"	2-5/32"	1-29/32"	15/16"	1/4"	11/64"	1-23/32"	27.5



Produced from 1018 cold heading quality wire.

*From under head

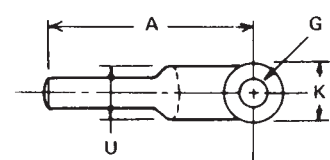
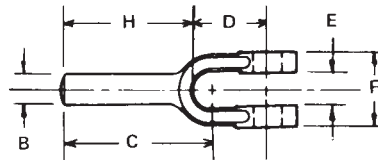

PLAIN TYPE, SELF-COLORED DROP FORGED YOKE ENDS

Stock No.	Part No.	Dimensions in Inches – Machined										Est. Wt. Per 100 Pcs.
		A	B	C	D	E	F	G	H	K	U	
61	19705 2	1-3/4"	1/4"	1-19/32"	5/8"	9/32"	5/8"	1/4"	1-1/8"	1/2"	7/16"	5 Lbs.
62	19710 6	2"	5/16"	1-7/16"	3/4"	11/32"	3/4"	5/16"	1-1/4"	19/32"	1/2"	8 Lbs.
63	19715 1	2-1/8"	3/8"	1-33/64"	27/32"	7/16"	7/8"	3/8"	1-9/32"	11/16"	5/8"	11 Lbs.
64	19720 5	2-1/4"	7/16"	1-57/64"	1"	1/2"	1"	7/16"	1-1/4"	13/16"	23/32"	17 Lbs.
65	19725 0	2-1/2"	1/2"	1-11/16"	1-1/8"	9/16"	1-1/8"	1/2"	1-3/8"	15/16"	13/16"	19 Lbs.
66	19730 4	2-7/8"	5/8"	1-53/64"	1-7/16"	11/16"	1-3/8"	5/8"	1-7/16"	1-3/16"	1-1/16"	43 Lbs.
67	19735 9	3-5/8"	3/4"	2-25/64"	1-11/16"	13/16"	1-5/8"	3/4"	1-15/16"	1-7/16"	1-1/8"	66 Lbs.

MALLEABLE BEVEL WASHERS



Bevelled 2" in 12" which is standard for flanges of beams and channels. Available in self-colored or hot galvanized finish.

MALLEABLE BEVEL WASHERS

Bolt Diameter	Black Part No.	Hot Galvanized Part No.	Dimensions - Inches				Weight Per 100 (Lbs.)
			A	B	C	D	
1/4"	06305 0	06355 5	11/16"	7/32"	5/64"	5/16"	2
5/16"	06308 1	06358 6	1"	5/16"	9/64"	3/8"	6
3/8"	06311 1	06361 6	1-1/4"	11/32"	5/32"	7/16"	9.3
1/2"	06314 2	06364 7	1-1/4"	11/32"	5/32"	9/16"	8.8
5/8"	06317 3	06367 8	1-1/2"	13/32"	5/32"	11/16"	12.4
3/4"	06320 3	06370 8	1-1/2"	15/32"	7/32"	13/16"	15
7/8"	06323 4	06373 9	2"	9/16"	7/32"	15/16"	34
1"	06326 5	06376 0	2"	9/16"	7/32"	1-3/32"	31.5
1-1/8"	06329 6	06379 1	2-1/4"	5/8"	9/32"	1-3/16"	43.5
1-1/4"	06332 6	06382 1	2-1/4"	23/32"	5/16"	1-11/32"	68.5

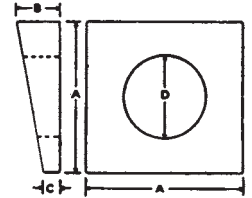

ZINC PLATED S-HOOKS

Low carbon cold drawn steel wire. Supplied with blunt ends and zinc plated finish. Standard Pack – 50 pieces. Other rust preventive coatings and self-colored (black) available on a special basis. "S" Hooks also manufactured to specifications.

ZINC PLATED S-HOOKS

Stock No.	Part No.	Dimensions - Inches				Weight Per 100 (Lbs.)	Working Load Limit (Lbs.)
		Wire Diameter	Overall Length	Hooks Inside Dia.	Opening Hooks		
S-1	06105 6	.080"	3/4"	1/4"	1/8"	.26	7
S-1A	06108 7	.105"	1"	5/16"	5/32"	.55	16
S-2	06111 7	.114"	1-1/4"	3/8"	3/16"	.83	17
S-2A	06114 8	.148"	1-1/2"	7/16"	7/32"	1.62	26
S-3	06117 9	.186"	1-3/4"	1/2"	1/4"	2.97	40
S-4	06120 9	.220"	2-1/8"	5/8"	5/16"	5.15	58
S-5	06123 0	.250"	2-1/2"	3/4"	7/16"	7.5	70
S-6	06126 1	.312"	3"	7/8"	1/2"	13.9	132
S-7	06129 2	.375"	3-1/2"	1"	1/2"	23.44	170



Available in stainless steel. See page 43.

WARNING:

Any deviations such as angular lifts, shock loads, modification of the "S" hook will result in drastically reduced working load limits.

CLEVIS PINS – HEAT TREATED

SELF-COLORED OR HOT GALVANIZED

Self-Colored Part No.	Hot Galvanized Part No.	Shank Diameter	Dimensions in Inches						Weight Per 100 In Lbs.
			Lengths		Head		Hole		
			Overall	Under Head	O.D.	Thickness	I.D.	*Center	
19005 3	19105 0	1/4"	1-1/4"	1-1/8"	7/16"	1/8"	7/64"	1-1/32"	1.9
19010 7	19110 4	5/16"	1-1/2"	1-3/8"	1/2"	1/8"	7/64"	1-1/4"	3.4
19015 2	19115 9	3/8"	1-11/16"	1-1/2"	9/16"	3/16"	1/8"	1-11/32"	5.7
19020 6	19120 3	7/16"	1-11/16"	1-1/2"	3/4"	3/16"	1/8"	1-23/64"	8.4
19025 1	19125 8	7/16"	1-15/16"	1-3/4"	3/4"	3/16"	1/8"	1-5/8"	9.5
19030 5	19130 2	1/2"	2-5/32"	1-15/16"	13/16"	7/32"	1/8"	1-13/16"	13.3
19035 0	19135 7	5/8"	2-17/32"	2-5/16"	1-1/32"	7/32"	5/32"	2-5/32"	24
19040 4	19140 1	3/4"	3"	2-3/4"	1-3/16"	1/4"	3/16"	2-9/16"	40
19045 9	19145 6	7/8"	3-1/2"	3-1/4"	1-1/4"	1/4"	13/64"	3"	62
19050 3	19150 0	1"	4-5/32"	3-25/32"	1-7/16"	3/8"	13/64"	3-17/32"	96
19055 8	19155 5	1-1/8"	4-5/8"	4-1/4"	1-5/8"	3/8"	13/64"	3-15/16"	134



*From under head



ROUND BEND U-BOLTS



Standard Pack:
10 Pieces

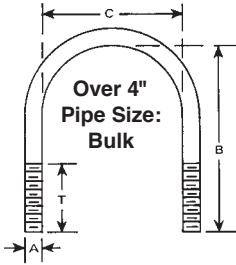

Over 4"
Pipe Size:
Bulk



Some sizes also available in Stainless Steel. See page 44.

NOTE:
Hex Nuts are imported

U-Bolt Specifications					U-Bolts & 2 Nuts					U-Bolts, Plates & 2 Nuts				
Dia. & Thread (A)	I.D. (C)	Inside Length (B)	Thread Length (T)	For Pipe Size	Zinc Plated		Hot Galvanized		Wt Per 100	Zinc Plated		Hot Galvanized		Wt Per 100
					Stock #	Part #	Stock #	Part #		Stock #	Part #	Stock #	Part #	
1/4"-20	9/16"	1-1/4"	3/4"	1/4"	01	50005 0	01HG	53005 7	5	1	50205 4	1HG	53605 9	7
1/4"-20	3/4"	1-1/4"	5/8"	3/8"	02	50008 1	02HG	53008 8	5	2	50208 5	2HG	53608 0	7
1/4"-20	3/4"	2-1/4"	1-1/2"	3/8"	03	50011 1	03HG	53011 8	7	3	50211 5	3HG	53611 0	9
1/4"-20	1"	1-3/4"	1"	1/2"	04	50014 2	04HG	53014 9	7	4	50214 6	4HG	53614 1	9
1/4"-20	1"	2-3/4"	1-1/4"	1/2"	04L	50017 3	04LHG	53017 0	8	4L	50217 7	4LHG	53617 2	11
1/4"-20	1-1/8"	2"	1"	3/4"	05	50020 3	05HG	53020 0	7	5	50220 7	5HG	53620 2	9
1/4"-20	1-1/8"	3-1/8"	1-1/2"	3/4"	05L	50023 4	05LHG	53023 1	9	5L	50223 8	5LHG	53623 3	12
1/4"-20	1-1/4"	2-1/4"	1-1/4"	3/4"	06	50026 5	06HG	53026 2	7.5	6	50226 9	6HG	53626 4	10
1/4"-20	1-1/2"	2-3/4"	1-3/8"	1"	07	50029 6	07HG	53029 3	9	7	50229 0	7HG	53629 5	12
1/4"-20	1-3/4"	3"	1-3/8"	1-1/4"	08	50032 6	08HG	53032 3	9	8	50232 0	8HG	53632 5	12
1/4"-20	2"	3-1/4"	1-3/8"	1-1/2"	09	50035 7	09HG	53035 4	9.5	9	50235 1	9HG	53635 6	14
5/16"-18	1"	2-3/16"	1-3/8"	1/2"	010	50038 8	010HG	53038 5	11	10	50238 2	10HG	53638 7	14
5/16"-18	1-1/8"	2-3/16"	1"	3/4"	0101	50041 8	0101HG	53041 5	12	101	50241 2	101HG	53641 7	14.5
5/16"-18	1-3/8"	2-3/16"	1"	1"	011	50044 9	011HG	53044 6	12	11	50244 3	11HG	53644 8	15
5/16"-18	1-3/8"	3-5/8"	2"	1"	011L	50047 0	011LHG	53047 7	16	11L	50247 4	11LHG	53647 9	20
5/16"-18	1-1/2"	2-3/16"	1"	1"	012	50050 0	012HG	53050 7	12	12	50250 4	12HG	53650 9	15
5/16"-18	1-3/4"	2-11/16"	1-1/8"	1-1/4"	013	50053 1	013HG	53053 8	13	13	50253 5	13HG	53653 0	17.5
5/16"-18	1-3/4"	4-1/2"	2"	1-1/4"	013L	50056 2	013LHG	53056 9	19	13L	50256 6	13LHG	53656 1	24
5/16"-18	2"	2-11/16"	1"	1-1/2"	014	50059 3	014HG	53059 0	14	14	50259 7	14HG	53659 2	19
5/16"-18	2"	4-3/4"	3"	1-1/2"	014L	50062 3	014LHG	53062 0	20	14L	50262 7	14LHG	53662 2	25
5/16"-18	2-1/2"	3-3/16"	1"	2"	015	50065 4	015HG	53065 1	16	15	50265 8	15HG	53665 3	21
5/16"-18	2-1/2"	5-5/8"	3"	2"	015L	50068 5	015LHG	53068 2	23	15L	50268 9	15LHG	53668 4	29
5/16"-18	3"	3-11/16"	1"	2-1/2"	016	50071 5	016HG	53071 2	18	16	50271 9	16HG	53671 4	24
3/8"-16	1"	2-1/4"	1-1/4"	1/2"	017	50074 6	017HG	53074 3	17.5	17	50274 0	17HG	53674 5	22.5
3/8"-16	1-1/4"	2-1/4"	1-1/4"	3/4"	018	50077 7	018HG	53077 4	18	18	50277 1	18HG	53677 6	24
3/8"-16	1-1/2"	2-1/2"	1-1/4"	1"	019	50080 7	019HG	53080 4	18.5	19	50280 1	19HG	53680 6	26
3/8"-16	1-3/4"	2-3/4"	1-1/8"	1-1/4"	020	50083 8	020HG	53083 5	20	20	50283 2	20HG	53683 7	27.5
3/8"-16	2"	2-5/8"	1-1/4"	1-1/2"	021	50086 9	021HG	53086 6	20	21	50286 3	21HG	53686 8	29
3/8"-16	2-1/2"	3-1/8"	1-1/4"	2"	022	50089 0	022HG	53089 7	24.5	22	50289 4	22HG	53689 9	33
3/8"-16	3"	3-5/8"	1-1/4"	2-1/2"	023	50092 0	023HG	53092 7	26	23	50292 4	23HG	53692 9	38
3/8"-16	3"	6-5/8"	3"	2-1/2"	023L	50095 1	023LHG	53095 8	41	23L	50295 5	23LHG	53695 0	52.5
3/8"-16	3-1/2"	4-1/8"	1-1/4"	3"	024	50098 2	024HG	53098 9	30	24	50298 6	24HG	53698 1	42.5
1/2"-13	3"	4-1/2"	1-5/8"	2-1/2"	025	50101 9	025HG	53101 6	59	25	50301 3	25HG	53701 8	71
1/2"-13	3-1/2"	5"	1-1/2"	3"	026	50104 0	026HG	53104 7	64	26	50304 4	26HG	53704 9	78
1/2"-13	3-1/2"	8-1/2"	3"	3"	026L	50107 1	026LHG	53107 8	95	26L	50307 5	26LHG	53707 0	110
1/2"-13	4"	5-1/2"	1-1/2"	3-1/2"	027	50110 1	027HG	53110 8	70	27	50310 5	27HG	53710 0	87
1/2"-13	4-1/2"	6"	1-1/2"	4"	028	50113 2	028HG	53113 9	75	28	50313 6	28HG	53713 1	92.5
1/2"-13	5-5/8"	7-1/4"	2"	5"	029	50116 3	029HG	53116 0	90	N.A.	N.A.	N.A.	N.A.	N.A.
1/2"-13	6-3/4"	8-3/8"	2"	6"	030	50119 4	030HG	53119 1	101	N.A.	N.A.	N.A.	N.A.	N.A.
1/2"-13	8-3/4"	10-3/8"	2"	8"	031	50122 4	031HG	53122 1	120	N.A.	N.A.	N.A.	N.A.	N.A.
*3/4"-10	10-7/8"	13-13/16"	4"	10"	032	50125 5	032HG	53125 2	440	N.A.	N.A.	N.A.	N.A.	N.A.
*7/8"-9	12-7/8"	16-1/16"	4-1/4"	12"	033	50128 6	033HG	53128 3	710	N.A.	N.A.	N.A.	N.A.	N.A.
*7/8"-9	14-1/8"	17-5/16"	4-1/4"	14"	034	50131 6	034HG	53131 3	755	N.A.	N.A.	N.A.	N.A.	N.A.
*7/8"-9	16-1/8"	19-5/16"	4-1/4"	16"	035	50134 7	035HG	53134 4	850	N.A.	N.A.	N.A.	N.A.	N.A.
*1"-8	18-1/8"	21-11/16"	4-3/4"	18"	036	50137 8	036HG	53137 5	1245	N.A.	N.A.	N.A.	N.A.	N.A.

*Full Stock Dia. with Cut Thread. • See page 33 for dims of steel pipe. • Stock numbers followed by "L" denote long length u-bolts

ROUND BEND U-BOLTS



Round Bend U-Bolts for Steel or Wrought Iron pipe sizes 1/4"-18" inclusive, are produced from low carbon steel and supplied with NC rolled threads and two (2) hex nuts (hex nuts are imported). In addition, U-Bolt plate is available if required. Zinc plated, hot galvanized and black oxide finishes are standard. Other types of coatings or self-colored available on a special basis. Round, Square or "V" type U-Bolts to 1" diameter manufactured to specifications in both ferrous and non-ferrous metals.

ALUMINUM & BLACK OXIDE U-BOLTS WITH 2 NUTS

U-Bolt Specifications					Aluminum			Black Oxide		
Dia. & Thread (A)	I.D. (C)	Inside Length (B)	Thread Length (T)	For Pipe Size	Stock No.	Part No.	Weight Per 100	Stock No.	Part No.	Weight Per 100
1/4"-20	3/4"	1-1/4"	5/8"	3/8"	02AL	60008 8	1.5	02BO	04601 5	5
1/4"-20	3/4"	2-1/4"	1-1/2"	3/8"	03AL	N/A	1.5	03BO	04603 9	7
1/4"-20	1"	1-3/4"	1"	1/2"	04AL	60014 9	2	04BO	04605 3	7
1/4"-20	1-1/8"	2"	1"	3/4"	05AL	60020 0	2	05BO	04607 7	7
1/4"-20	1-1/4"	2-1/4"	1-1/4"	3/4"	06AL	N/A	3	06BO	N/A	7.5
1/4"-20	1-1/2"	2-3/4"	1-3/8"	1"	07AL	60029 3	3.5	07BO	04609 1	9
1/4"-20	1-3/4"	3"	1-3/8"	1-1/4"	08AL	60032 3	4	08BO	04611 4	9
1/4"-20	2"	3-1/4"	1-3/8"	1-1/2"	09AL	60035 4	4	09BO	N/A	9.5
5/16"-18	1"	2-3/16"	1-3/8"	1/2"	010AL	N/A	4.5	010BO	04613 8	11
5/16"-18	1-3/8"	2-3/16"	1"	1"	011AL	60044 6	5	011BO	04615 2	12
5/16"-18	1-1/2"	2-3/16"	1"	1"	012AL	N/A	5	012BO	04617 6	12
5/16"-18	1-3/4"	2-11/16"	1-1/8"	1-1/4"	013AL	N/A	5.2	013BO	04619 0	13
5/16"-18	2"	2-11/16"	1"	1-1/2"	014AL	60059 0	5.2	014BO	04621 3	14
5/16"-18	2-1/2"	3-3/16"	1"	2"	015AL	60065 1	5.5	015BO	04623 7	16
5/16"-18	3"	3-11/16"	1"	2-1/2"	016AL	N/A	5.5	016BO	04625 1	18
3/8"-16	1"	2-1/4"	1-1/4"	1/2"	017AL	N/A	6	017BO	04627 5	17.5
3/8"-16	1-1/4"	2-1/4"	1-1/4"	3/4"	018AL	N/A	6	018BO	04629 9	18
3/8"-16	1-1/2"	2-1/2"	1-1/4"	1"	019AL	60080 4	6.5	019BO	04631 2	18.5
3/8"-16	1-3/4"	2-3/4"	1-1/8"	1-1/4"	020AL	N/A	7	020BO	04633 6	20
3/8"-16	2"	2-5/8"	1-1/4"	1-1/2"	021AL	60086 6	7	021BO	N/A	20
3/8"-16	2-1/2"	3-1/8"	1-1/4"	2"	022AL	60089 7	7.1	022BO	04635 0	24.5
3/8"-16	3"	3-5/8"	1-1/4"	2-1/2"	023AL	N/A	8.5	023BO	04637 4	26
3/8"-16	3-1/2"	4-1/8"	1-1/4"	3"	024AL	60098 9	10.5	024BO	04639 8	30
1/2"-13	3"	4-1/2"	1-5/8"	2-1/2"	025AL	N/A	20.5	025BO	04641 1	59
1/2"-13	3-1/2"	5"	1-1/2"	3"	026AL	60104 7	22.5	026BO	04643 5	64
1/2"-13	4"	5-1/2"	1-1/2"	3-1/2"	027AL	N/A	25	027BO	04645 9	70
1/2"-13	4-1/2"	6"	1-1/2"	4"	028AL	60113 9	27	028BO	04647 3	75
1/2"-13	5-5/8"	7-1/4"	2"	5"	029AL	N/A	32	029BO	04649 7	90
1/2"-13	6-3/4"	8-3/8"	2"	6"	030AL	60119 1	36	030BO	N/A	101

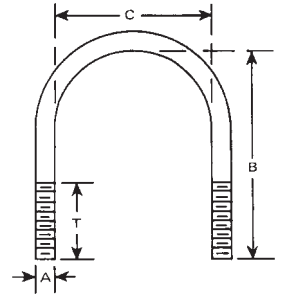

Some sizes also available in Stainless Steel. See page 44.

*Full Stock Diameter with Cut Thread

DIMENSIONS OF WELDED AND SEAMLESS STEEL PIPE

Pipe Size	1/4"	3/8"	1/2"	3/4"	1"	1-1/4"	1-1/2"	2"	2-1/2"	3"	3-1/2"	4"	5"	6"	8"	10"	12"	14"	16"	18"
Outside Dia.	.540"	.675"	.840"	1.05"	1.315"	1.66"	1.90"	2.375"	2.875"	3.500"	4.000"	4.500"	5.563"	6.625"	8.625"	10.750"	12.750"	14.000"	16.000"	18.000"

U-BOLT DISPLAY



U-BOLT DISPLAY PART # 60040 8

Qty.	Stock #	Pipe Size	Thread Dia.
10	4	1/2"	1/4"-20
10	5	3/4"	1/4"-20
10	5L	3/4"	1/4"-20
10	7	1"	1/4"-20
10	11	1"	5/16"-18
10	11L	1"	5/16"-18
10	13	1-1/4"	5/16"-18
10	13L	1-1/4"	5/16"-18
10	14	1-1/2"	5/16"-18
10	14L	1-1/2"	5/16"-18
10	15	2"	5/16"-18
10	15L	2"	5/16"-18
10	22	2"	3/8"-16
10	24	3"	3/8"-16

140 U-Bolts Shipping Wt. 35 lbs.

U-BOLT PLATES



U-Bolt plates are low carbon cold rolled steel with rounded edges and zinc plated or hot galvanized finish. Plate holes are punched "on centers" of corresponding size U-Bolt and identified by stock numbers.

Dimensions - Inches		
For U-Bolt Diameter	Gauge	Width
1/4" and 5/16"	.078"	.750"
3/8" and 1/2"	.109"	1.000"



ROUND BEND LONG TANGENT U-BOLTS



Zinc Plated

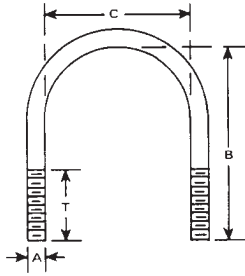

Hot Galvanized



NOTE:
Hex Nuts
are imported

Some sizes
also available in
Stainless Steel.
See page 45.

ZINC PLATED & HOT GALVANIZED LONG TANGENT U-BOLTS WITH 4 NUTS

U-Bolt Specifications						Zinc Plated		Hot Galvanized	
Diameter (A)	Inside Width (C)	Inside Length (B)	Thread Length (T)	Pipe Size	Weight Per 100	Stock No.	Part No.	Stock No.	Part No.
1/4"-20	7/8"	2-15/16"	2-1/2"	1/2"	9	LT-B	51460 6	LT-BHG	53165 8
1/4"-20	1-1/8"	3-3/16"	2-1/2"	3/4"	10	LT-C	51465 1	LT-CHG	53175 7
1/4"-20	1-3/8"	3-7/16"	2-1/2"	1"	11	LT-D	51470 5	LT-DHG	53180 1
3/8"-16	15/16"	3"	2-3/8"	1/2"	24	LT-1	51505 4	LT-1 HG	53205 1
3/8"-16	1-1/8"	3-5/16"	2-3/8"	3/4"	25.5	LT-2	51510 8	LT-2 HG	53210 5
3/8"-16	1-3/8"	3-7/16"	2-3/8"	1"	26.5	LT-3	51515 3	LT-3 HG	53215 0
3/8"-16	1-11/16"	3-23/32"	2-3/8"	1-1/4"	28	LT-4	51520 7	LT-4 HG	53220 4
3/8"-16	2"	4"	2-1/2"	1-1/2"	30	LT-5	51525 2	LT-5 HG	53225 9
3/8"-16	2-7/16"	4-7/16"	2-1/2"	2"	33	LT-6	51530 6	LT-6 HG	53230 3
1/2"-13	2-15/16"	5-7/32"	3"	2-1/2"	71	LT-7	51535 1	LT-7 HG	53235 8
1/2"-13	3-9/16"	5-3/4"	3"	3"	77	LT-8	51540 5	LT-8 HG	53240 2
1/2"-13	4-1/16"	6-1/4"	3"	3-1/2"	82	LT-9	51545 0	LT-9 HG	53245 7
1/2"-13	4-9/16"	6-3/4"	3"	4"	89	LT-10	51550 4	LT-10 HG	53250 1
1/2"-13	5-5/8"	7-13/16"	3"	5"	101	LT-11	51555 9	LT-11 HG	53255 6
5/8"-11	6-3/4"	9-1/2"	3-3/4"	6"	194.5	LT-12	51560 3	LT-12 HG	53260 0
5/8"-11	8-3/4"	11-1/8"	3-3/4"	8"	223.5	LT-13	51565 8	LT-13 HG	53265 5
3/4"-10	10-7/8"	13-13/16"	4"	10"	460	LT-14	51570 2	LT-14 HG	53270 9

SQUARE BEND U-BOLTS

Furnished with 3/8" nuts and flat washers.

ZINC PLATED & HOT GALVANIZED SQUARE BEND U-BOLTS WITH 2 NUTS & 2 WASHERS



U-Bolt Specifications					Zinc Plated		Hot Galvanized	
Diameter (A)	Inside Width (C)	Overall Length (B)	Thread Length (T)	Weight Per 100	Stock No.	Part No.	Stock No.	Part No.
3/8"-16	2"	3"	1-1/2"	25.5	SB-1	51005 9	SB-1HG	53405 5
3/8"-16	2"	5"	3"	35.5	SB-2	51010 3	SB-2HG	53410 9
3/8"-16	2"	7"	3-3/4"	44.5	SB-3	51015 8	SB-3HG	53415 4
3/8"-16	4"	3"	1-1/2"	29.5	SB-4	51020 2	SB-4HG	53420 8
3/8"-16	4"	5"	3"	40	SB-5	51025 7	SB-5HG	53425 3
3/8"-16	4"	7"	3-3/4"	49.5	SB-6	51030 1	SB-6HG	53430 7
3/8"-16	6"	5"	3"	44.5	SB-7	51035 6	SB-7HG	53435 2
3/8"-16	6"	7"	3-3/4"	56	SB-8	51040 0	SB-8HG	53440 6
3/8"-16	6"	9"	5-5/8"	63	SB-9	51045 5	SB-9HG	53445 1



Zinc Plated

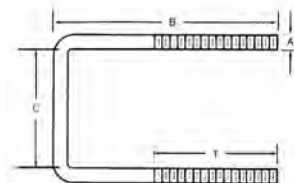

Hot Galvanized

Also available in Stainless Steel.
See page 45.

NOTE:
Hex Nuts
and Washers
are imported

ZINC PLATED TURNED EYE BOLTS



Turned eye bolts are manufactured from low carbon cold drawn steel wire and are supplied with NC rolled machine threads with one hex nut unassembled. Zinc plated finish is standard; other types of coating or self-colored available on a special basis. When it is not feasible to utilize a standard eye bolt, we can manufacture to your specifications.

MACHINE THREAD



NOTE:
Hex Nuts
are imported

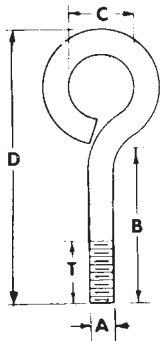

Some sizes
also available in
Stainless Steel.
See page 43.

Stock No.	Part No.	Dimensions - Inches					Weight Per 100 in lbs.	Working Load Limit (lbs.)
		Thread Diameter (A)	Shank Length (B)	I.D. Eye (C)	Overall Length (D)	Thread Length (T)		
A-1	07005 8	1/8" (6-32)	3/4"	1/4"	1-1/4"	5/8"	.75	22
B-1	07010 2	5/32" (8-32)	1-1/8"	1/4"	1-11/16"	1"	1.31	36
C-1	07015 7	3/16" (10-24)	1"	3/8"	1-11/16"	7/8"	1.81	38
C-2	07020 1	3/16" (10-24)	1-3/8"	5/16"	2"	1-1/4"	1.875	38
C-3	07025 6	3/16" (10-24)	2"	3/8"	2-11/16"	1"	2.375	38
C-4	07030 0	3/16" (10-24)	3"	3/8"	3-11/16"	1-1/2"	2.94	38
D-1	07035 5	7/32" (12-24)	1-1/2"	3/8"	2-1/4"	1-3/8"	1.67	52
E-1	07040 9	1/4"-20	1"	1/2"	2"	7/8"	3.75	74
E-2	07045 4	1/4"-20	1-1/2"	1/2"	2-1/2"	1-1/4"	4.375	74
E-2A	07050 8	1/4"-20	1-7/8"	7/16"	2-3/4"	1-5/8"	5.2	74
E-3	07055 3	1/4"-20	2"	1/2"	3"	1-1/4"	5	74
E-4	07060 7	1/4"-20	2-1/2"	1/2"	3-1/2"	1-1/4"	5.6	74
E-5	07065 2	1/4"-20	3"	1/2"	4"	1-1/2"	6.3	74
E-6	07070 6	1/4"-20	3-1/2"	1/2"	4-1/2"	2"	6.9	74
E-7	07075 1	1/4"-20	4"	1/2"	5"	2-1/2"	7.5	74
E-8	07080 5	1/4"-20	5"	1/2"	6"	3"	8	74
E-9	07085 0	1/4"-20	6"	1/2"	7"	4"	9	74
F-1	07090 4	5/16"-18	1"	5/8"	2-1/8"	7/8"	7	96
F-2	07095 9	5/16"-18	2"	5/8"	3-1/8"	1-1/4"	9	96
F-2A	07100 0	5/16"-18	2-1/4"	9/16"	3-3/8"	2"	9.7	96
F-3	07105 5	5/16"-18	2-1/2"	5/8"	3-5/8"	1-1/4"	10	96
F-4	07110 9	5/16"-18	3"	5/8"	4-1/8"	1-1/2"	11	96
F-5	07115 4	5/16"-18	3-1/2"	5/8"	4-5/8"	2"	11	96
F-6	07120 8	5/16"-18	4"	5/8"	5-1/8"	2-1/2"	12	96
F-7	07125 3	5/16"-18	5"	5/8"	6-1/8"	3"	14	96
F-8	07130 7	5/16"-18	6"	5/8"	7-1/8"	4"	15	96
F-9	07135 2	5/16"-18	6-1/2"	7/8"	7-3/4"	4"	18	96
G-1	07140 6	3/8"-16	1"	3/4"	2-1/2"	7/8"	12	144
G-1.5	07142 0	3/8"-16	1-1/2"	3/4"	3"	1-1/8"	13	144
G-2	07145 1	3/8"-16	2"	3/4"	3-1/2"	1-1/4"	15	144
G-2A	07150 5	3/8"-16	2-1/2"	21/32"	3-3/4"	2-1/4"	15.7	144
G-3	07155 0	3/8"-16	2-1/2"	3/4"	4"	1-1/2"	15.5	144
G-4	07160 4	3/8"-16	3"	3/4"	4-1/2"	1-1/2"	17	144
G-5	07165 9	3/8"-16	3-1/2"	3/4"	5"	2"	18	144
G-6	07170 3	3/8"-16	4"	3/4"	5-1/2"	2-1/2"	21	144
G-7	07175 8	3/8"-16	5"	3/4"	6-1/2"	3"	22	144
G-8	07180 2	3/8"-16	6"	3/4"	7-1/2"	4"	24	144
G-9	07185 7	3/8"-16	8"	3/4"	9-1/2"	4"	30	144
G-10	07190 1	3/8"-16	10"	3/4"	11-1/2"	4"	34	144
G-11	07195 6	3/8"-16	12"	3/4"	13-1/2"	4"	39	144
H-1	07200 7	7/16"-14	6"	7/8"	7-3/4"	4"	36	216
H-2	07205 2	7/16"-14	8"	7/8"	9-3/4"	4"	42	216
J-1	07210 6	1/2"-13	2"	1"	4"	1-1/2"	33	298
J-1.5	07212 0	1/2"-13	3"	1"	5"	1-1/2"	37	298
J-2	07215 1	1/2"-13	4"	1"	6"	2-1/2"	41	298
J-3	07220 5	1/2"-13	6"	1"	8"	4"	50	298
J-4	07225 0	1/2"-13	8"	1"	10"	4"	58	298
J-5	07230 4	1/2"-13	10"	1"	12"	4"	68	298

Standard Pack: A-1 through D-1: 50 Pieces; E-1 through J-5: 10 Pieces



ZINC PLATED TURNED EYE BOLTS

LAG THREADS



Lag Screw threaded Turned Eye Bolts are comparable in steel specification, finish and packaging to machine thread Turned Eye Bolts listed on page 35. Lag screw threads are rolled to fit standard anchors and shields and supplied with gimlet point.

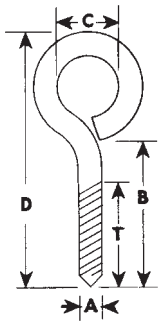

Stock No.	Part No.	Dimensions - Inches					Weight Per 100 in lbs.
		Thread Diameter (A)	Shank Length (B)	I.D. Eye (C)	Overall Length (D)	Thread Length (T)	
LS-1	07855 9	1/4"	2-3/4"	1/2"	3-11/16"	2"	5
LS-2	07860 3	1/4"	4"	1/2"	4-7/8"	2"	6
LS-3	07865 8	5/16"	2-3/4"	5/8"	3-7/8"	2"	8
LS-4	07870 2	5/16"	4-3/4"	5/8"	5-13/16"	2"	11
LS-5	07875 7	3/8"	3"	3/4"	4-3/8"	2-1/2"	13
LS-6	07880 1	3/8"	6"	3/4"	7-5/16"	2-1/2"	19
LS-7	07885 6	1/2"	3-1/2"	1"	5-1/4"	2-3/4"	30

Standard Pack - 10 Pieces

TURNED EYE BOLT DISPLAY PART # 60030 9		
Qty.	Stock No.	Diameter & Shank Length
10	C-1	3/16" x 1"
10	C-2	3/16" x 1-3/8"
10	C-3	3/16" x 2"
10	E-1	1/4" x 1"
10	E-2	1/4" x 1-1/2"
10	E-3	1/4" x 2"
10	E-5	1/4" x 3"
10	E-7	1/4" x 4"
10	F-2	5/16" x 2"
10	F-4	5/16" x 3"
10	F-6	5/16" x 4"
10	F-7	5/16" x 5"
10	G-3	3/8" x 2-1/2"
10	G-5	3/8" x 3-1/2"
10	G-6	3/8" x 4"
10	G-8	3/8" x 6"
10	J-2	1/2" x 4"
10	J-3	1/2" x 6"
10	J-4	1/2" x 8"
190 Eyebolts Shipping Wt. 37 lbs.		

TURNED EYE BOLT DISPLAY

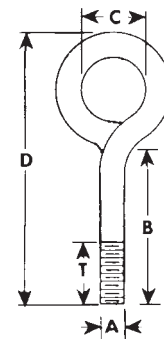

WELDED - MACHINE THREADS

Comparable in specifications, finish and standard packaging with exception: Eyes are resistance welded closed before plating.



NOTE:
Hex Nuts
are imported

Stock No.	Part No.	Dimensions - Inches					Weight Per 100 in lbs.	Working Load Limit (lbs.)
		Thread Diameter (A)	Shank Length (B)	I.D. Eye (C)	Overall Length (D)	Thread Length (T)		
F-3W	07755 2	5/16"-18	2-1/2"	5/8"	3-5/8"	1-1/4"	10	240
G-3W	07760 6	3/8"-16	2-1/2"	3/4"	4"	1-1/2"	16	400
G-6W	07765 1	3/8"-16	4"	3/4"	5-1/2"	2-1/2"	20	400
J-2W	07770 5	1/2"-13	4"	1"	6"	2-1/2"	41	1000
J-3W	07775 0	1/2"-13	6"	1"	8"	4"	50	1000

Standard Pack - 10 Pieces

CONTINUOUS THREADED ROD



Manufactured from Low Carbon Domestic Steel and color coded according to dia. per the chart below. All diameters and lengths available in National Coarse and National Fine threads. Other lengths and double-ended studs, manufactured to specification.

NATIONAL COARSE THREAD—LOW CARBON STEEL

SELF-COLORED (S.C.) & ZINC PLATED (Z.P.): 12"—24"—36"—72"—120"—144" LENGTHS

Thread Diameter	Color Code	12" RODS		24" RODS		36" RODS		72" RODS		120" RODS		144" RODS		Est. Wt Per 100 Ft. (lbs)
		S.C. Part No.	Z.P. Part No.	S.C. Part No.	Z.P. Part No.	S.C. Part No.	Z.P. Part No.	S.C. Part No.	Z.P. Part No.	S.C. Part No.	Z.P. Part No.	S.C. Part No.	Z.P. Part No.	
6 - 32	Blue	39005 7	35005 1	39008 8	35008 2	39011 8	35011 2	39014 9	35014 3	39017 0	35017 4	39020 0	35020 4	3.6
8 - 32	Red	39025 5	35025 9	39028 6	35028 0	39031 6	35031 0	39034 7	35034 1	39037 8	35037 2	39040 8	35040 2	5.3
10 - 24	Green	39045 3	35045 7	39048 4	35048 8	39051 4	35051 8	39054 5	35054 9	39057 6	35057 0	39060 6	35060 0	6.7
12 - 24	Red	39065 1	35065 5	39068 2	35068 6	39071 2	35071 6	39074 3	35074 7	39077 4	35077 8	39080 4	35080 8	9.2
1/4" - 20	Blue	39085 9	35085 3	39088 0	35088 4	39091 0	35091 4	39094 1	35094 5	39097 2	35097 6	39100 9	35100 3	12.1
5/16" - 18	Red	39105 4	35105 8	39108 5	35108 9	39111 5	35111 9	39114 6	35114 0	39117 7	35117 1	39120 7	35120 1	19.6
3/8" - 16	Yellow	39125 2	35125 6	39128 3	35128 7	39131 3	35131 7	39134 4	35134 8	39137 5	35137 9	39140 5	35140 9	28.7
7/16" - 14	Green	39145 0	35145 4	39148 1	35148 5	39151 1	35151 5	39154 2	35154 6	39157 3	35157 7	39160 3	35160 7	39.8
1/2" - 13	Blue	39165 8	35165 2	39168 9	35168 3	39171 9	35171 3	39174 0	35174 4	39177 1	35177 5	39180 1	35180 5	52.6
9/16" - 12	Yellow	39185 6	35185 0	39188 7	35188 1	39191 7	35191 1	39194 8	35194 2	39197 9	35197 3	39200 6	35200 0	66.7
5/8" - 11	Red	39205 1	35205 5	39208 2	35208 6	39211 2	35211 6	39214 3	35214 7	39217 4	35217 8	39220 4	35220 8	83.3
3/4" - 10	Yellow	39225 9	35225 3	39228 0	35228 4	39231 0	35231 4	39234 1	35234 5	39237 2	35237 6	39240 2	35240 6	123
7/8" - 9	Green	39245 7	35245 1	39248 8	35248 2	39251 8	35251 2	39254 9	35254 3	39257 0	35257 4	39260 0	35260 4	170
1" - 8	Red	39265 5	35265 9	39268 6	35268 0	39271 6	35271 0	39274 7	35274 1	39277 8	35277 2	39280 8	35280 2	223
1-1/8" - 7	Yellow	39285 3	35285 7	39288 4	35288 8	39291 4	35291 8	39294 5	35294 9	39297 6	35297 0	39300 3	35300 7	280
1-1/4" - 7	Green	39305 8	35305 2	39308 9	35308 3	39311 9	35311 3	39314 0	35314 4	39317 1	35317 5	39320 1	35320 5	352
1-3/8" - 6	Blue	39325 6	35325 0	39328 7	35328 1	39331 7	35331 1	39334 8	35334 2	39337 9	35337 3	39340 9	35340 3	421
1-1/2" - 6	Red	39345 4	35345 8	39348 5	35348 9	39351 5	35351 9	39354 6	35354 0	39357 7	35357 1	39360 7	35360 1	510



NATIONAL FINE THREAD—LOW CARBON STEEL

SELF-COLORED (S.C.) & ZINC PLATED (Z.P.): 12"—24"—36"—72"—120"—144" LENGTHS

Thread Diameter	Color Code	12" RODS		24" RODS		36" RODS		72" RODS		120" RODS		144" RODS		Est. Wt Per 100 Ft. (lbs)
		S.C. Part No.	Z.P. Part No.	S.C. Part No.	Z.P. Part No.	S.C. Part No.	Z.P. Part No.	S.C. Part No.	Z.P. Part No.	S.C. Part No.	Z.P. Part No.	S.C. Part No.	Z.P. Part No.	
10 - 32	Yellow	45045 4	41045 8	45048 5	41048 9	45051 5	41051 9	45054 6	41054 0	45054 6	41057 1	45060 7	41060 1	7.2
1/4" - 28	Blue	45085 0	41085 4	45088 1	41088 5	45091 1	41091 5	45094 2	41094 6	45097 3	41097 7	45100 0	41100 4	12.9
5/16" - 24	Red	45105 5	41105 9	45108 6	41108 0	45111 6	41111 0	45114 7	41114 1	45117 8	41117 2	45120 8	41120 2	21.4
3/8" - 24	Yellow	45125 3	41125 7	45128 4	41128 8	45131 4	41131 8	45134 5	41134 9	45137 6	41137 0	45140 6	41140 0	31.2
7/16" - 20	Green	45145 1	41145 5	45148 2	41148 6	45151 2	41151 6	45154 3	41154 7	45157 4	41157 8	45160 4	41160 8	42.9
1/2" - 20	Blue	45165 9	41165 3	45168 0	41168 4	45171 0	41171 4	45174 1	41174 5	45177 2	41177 6	45180 2	41180 6	56.4
9/16" - 18	Yellow	45185 7	41185 1	45188 8	41188 2	45191 8	41191 2	45194 9	41194 3	45197 0	41197 4	45200 7	41200 1	75.3
5/8" - 18	Red	45205 2	41205 6	45208 3	41208 7	45211 3	41211 7	45214 4	41214 8	45217 5	41217 9	45220 5	41220 9	90.9
3/4" - 16	Yellow	45225 0	41225 4	45228 1	41228 5	45231 1	41231 5	45234 2	41234 6	45237 3	41237 7	45240 3	41240 7	132
7/8" - 14	Green	45245 8	41245 2	45248 9	41248 3	45251 9	41251 3	45254 0	41254 4	45257 1	41257 5	45260 1	41260 5	181
1" - 14	Red	45265 6	41265 0	45268 7	41268 1	45271 7	41271 1	45274 8	41274 2	45277 9	41277 3	45280 9	41280 3	240
1-1/8" - 12	Yellow	45285 4	41285 8	45288 5	41288 9	45291 5	41291 9	45294 6	41294 0	45297 7	41297 1	45300 4	41300 8	302
1-1/4" - 12	Green	45305 9	41305 3	45308 0	41308 4	45311 0	41311 4	45314 1	41314 5	45317 2	41317 6	45320 2	41320 6	378
1-3/8" - 12	Blue	45325 7	41325 1	45328 8	41328 2	45331 8	41331 2	45334 9	41334 3	45337 0	41337 4	45340 0	41340 4	421
1-1/2" - 12	Red	45345 5	41345 9	45348 6	41348 0	45351 6	41351 0	45354 7	41354 1	45357 8	41357 2	45360 8	41360 2	553



CONTINUOUS THREADED ROD

HOT GALVANIZED LOW CARBON STEEL 36" AND 72" LENGTHS

Thread Diameter	36" Length Part No.	72" Length Part No.	Wt Per 100 Ft. (lbs)
3/8" - 16	46131 3	46134 4	28.7
7/16" - 14	46151 1	46154 2	39.8
1/2" - 13	46171 9	46174 0	52.6
5/8" - 11	46211 2	46214 3	83.3
3/4" - 10	46231 0	46234 1	123
7/8" - 9	46251 8	46254 9	170
1" - 8	46271 6	46274 7	223
1-1/4" - 7	46311 9	46314 0	352



B7-ALLOY – SELF-COLORED 36", 72" AND 144" LENGTHS

Thread Diameter	36" Length Part No.	72" Length Part No.	144" Length Part No.	Weight Per 100 Ft. (lbs)
1/4" - 20	38091 1	38094 2	38100 0	12.1
5/16" - 18	38111 6	38114 7	38120 8	19.6
3/8" - 16	38131 4	38134 5	38140 6	28.7
7/16" - 14	38151 2	38154 3	38160 4	39.8
1/2" - 13	38171 0	38174 1	38180 2	52.6
5/8" - 11	38211 3	38214 4	38220 5	83.3
3/4" - 10	38231 1	38234 2	38240 3	123
7/8" - 9	38251 9	38254 0	38260 1	170
1" - 8	38271 7	38274 8	38280 9	223
1-1/8" - 7	38291 5	38294 6	38300 4	280
1-1/8" - 8	38311 0	38314 1	38320 2	292
1-1/4" - 7	38331 8	38334 9	38340 0	352
1-1/4" - 8	38351 6	38354 7	38360 8	366
1-1/2" - 6	38391 2	38394 3	38400 1	510
1-1/2" - 8	38411 7	38414 8	38420 9	534



NOTE: Ends are painted white.

ZINC PLATED* STEEL COUPLING NUTS & ROUNDS

COUPLING NUTS

Tap Size	Part No.	Out-side Hex	Overall Length	Pcs Per Pkg	Est. Wt Per Pkg (lbs)	Est. Wt Per 100 (lbs)
10 - 24	25505 9	5/16"	3/4"	50	.35	.7
1/4" - 20	25510 3	3/8"	7/8"	50	1	2
5/16" - 18	25515 8	1/2"	1-1/8"	25	.75	3
3/8" - 16	25520 2	5/8"	1-3/4"	25	2.9	11
7/16" - 14	25525 7	5/8"	1-3/4"	25	2.6	10
1/2" - 13	25530 1	11/16"	1-3/4"	25	3	12
5/8" - 11	25535 6	13/16"	2-1/8"	20	3.7	18
3/4" - 10	25540 0	1"	2-1/4"	20	6	29
7/8" - 9	25545 5	1-1/4"	2-1/2"	10	5.3	53
1" - 8	25550 9	1-3/8"	2-3/4"	10	7	70
1-1/8" - 7	25555 4	1-1/2"	3"	10	9	90
1-1/4" - 7	25560 8	1-5/8"	3"	10	9.8	97

National Coarse Right Hand Thread. For joining threaded rods where span of application exceeds 144" or where a threaded fitting is used with threaded rod in suspension applications.



* Also available in self-colored finish for welding.

ROUNDS

Diameter or Size	Color Code	Part No.	Length Inches	Est. Wt Per 100 Ft. (lbs)
3/16"	Green	28105 8	36"	9.4
1/4"	Blue	28110 2	36"	16.7
5/16"	Red	28115 7	36"	26.1
3/8"	Yellow	28120 1	36"	37.6
7/16"	Green	28125 6	36"	51.1
1/2"	Blue	28130 0	36"	66.8
5/8"	Red	28135 5	36"	104.3
3/4"	Yellow	28140 9	36"	150.2
7/8"	Green	28145 4	36"	204
1"	Red	28150 8	36"	267

Some sizes are available in stainless steel on a special basis.

Diameters 3/16" to 3/4" inclusive are cold drawn steel. Produced to cold finish tolerances. 7/8" and 1" rounds are Hot Rolled. 72", 120" and 144" lengths are also available.



ZINC PLATED MILD STEEL "SHAPES"



Special lengths available upon request.
 ** Also available in self-colored finish for welding.



SQUARE KEY**

Size	12" Length Part No.	24" Length Part No.	36" Length Part No.	Est. Wt Per 100 Ft. (lbs)
1/8"	31005 5	31505 0	31250 9	5.3
5/32"	31010 9	31510 4	31253 0	8.3
3/16"	31015 4	31515 9	31256 1	12
1/4"	31020 8	31520 3	31259 2	22
5/16"	31025 3	31525 8	31262 2	33
3/8"	31030 7	31535 7	31265 3	48
7/16"	31035 2	31540 1	31268 4	65
1/2"	31040 6	31545 6	31271 4	85
9/16"	31045 1	31550 0	31274 5	108
5/8"	31050 5	31555 5	31277 6	133
11/16"	31055 0	31560 9	31280 6	160
3/4"	31060 4	31565 4	31283 7	190
13/16"	31065 9	31570 8	31286 8	225
7/8"	31070 3	31575 3	31289 9	260
1"	31075 8	31580 7	31292 9	340



Cold Finished Squares.

FLATS**

Sizes & Lengths	Part No.	Est. Wt Per 100 Feet (lbs)
1/8" x 3/4" x 36"	29105 7	31.9
1/8" x 3/4" x 48"	29110 1	31.9
1/8" x 3/4" x 72"	29120 0	31.9
1/8" x 1" x 36"	29125 5	42.5
1/8" x 1" x 48"	29130 9	42.5
1/8" x 1" x 72"	29140 8	42.5
1/8" x 1-1/4" x 36"	29145 3	53.1
1/8" x 1-1/4" x 48"	29150 7	53.1
1/8" x 1-1/4" x 72"	29160 6	53.1

Produced with Round Edges—12 foot maximum length available.



SLOTTED FLATS

Size	Part No.	Length Inches	Est. Wt Per 100 Ft. (lbs)
.080" x 1-3/8"	29705 9	36"	35
.080" x 1-3/8"	29710 3	48"	35
.080" x 1-3/8"	29715 8	60"	35
.080" x 1-3/8"	29720 2	72"	35



For use in tensioning angles, load dividers or hangers.

SLOTTED ANGLES

Size	Part No.	Length Inches	Est Wt Per 100 Ft. (lbs)
.074" x 1-1/2" x 1-1/2"	31705 4	36"	69
.074" x 1-1/2" x 1-1/2"	31710 8	48"	69
.074" x 1-1/2" x 1-1/2"	31715 3	60"	69
.074" x 1-1/2" x 1-1/2"	31720 7	72"	69
.074" x 1-1/2" x 1-1/2"	31725 2	120"	69
.074" x 1-1/2" x 1-1/2"	31730 6	144"	69



Framing materials for light duty applications are offered as Angles. Easily assembled with 5/16" x 3/4" hex head bolts with nuts – storage racks, tables, benches and carts to cite a few end uses.

ANGLES**

Sizes & Lengths	Part No.	Est. Wt Per 100 Feet (lbs)
1/8" x 3/4" x 3/4" x 36"	30105 3	59
1/8" x 3/4" x 3/4" x 48"	30110 7	59
1/8" x 3/4" x 3/4" x 60"	30115 2	59
1/8" x 3/4" x 3/4" x 72"	30120 6	59
1/8" x 1" x 1" x 36"	30125 1	80
1/8" x 1" x 1" x 48"	30130 5	80
1/8" x 1" x 1" x 60"	30135 0	80
1/8" x 1" x 1" x 72"	30140 4	80
1/8" x 1-1/4" x 1-1/4" x 36"	30145 9	101
1/8" x 1-1/4" x 1-1/4" x 48"	30150 3	101
1/8" x 1-1/4" x 1-1/4" x 60"	30155 8	101
1/8" x 1-1/4" x 1-1/4" x 72"	30160 2	101
3/16" x 2" x 2" x 36"	30165 7	244
3/16" x 2" x 2" x 48"	30170 1	244
3/16" x 2" x 2" x 60"	30175 6	244
3/16" x 2" x 2" x 72"	30180 0	244

Hot Rolled Angles.





STAINLESS STEEL SECTION

STAINLESS STEEL MACHINED ROD ENDS – TYPE 316

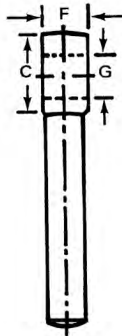
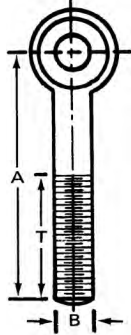

Part No.	Thread Pitch	Dimensions – Inches					Weight Per 100
		Length in Inches (A)*	Thread Length (T)	Hole I.D. (G)	Boss Diameter (C)	Boss Thickness (F)	
18541 7	1/4"-20	2"	3/4"	3/16"	1/2"	9/32"	4
18543 1	1/4"-20	2"	3/4"	1/4"	1/2"	9/32"	4
18545 5	1/4"-20	3"	3/4"	3/16"	1/2"	9/32"	4
18548 6	1/4"-20	3"	3/4"	1/4"	1/2"	9/32"	4
18550 9	1/4"-20	4"	3/4"	3/16"	1/2"	9/32"	5
18553 0	1/4"-20	4"	3/4"	1/4"	1/2"	9/32"	5
18554 7	5/16"-18	3"	1-1/2"	1/4"	5/8"	11/32"	8
18556 1	5/16"-18	3"	1-1/2"	5/16"	5/8"	11/32"	8
18558 5	5/16"-18	4"	2"	1/4"	5/8"	11/32"	9
18559 2	5/16"-18	4"	2"	5/16"	5/8"	11/32"	9
18561 5	3/8"-16	3"	1-1/2"	5/16"	3/4"	7/16"	12
18566 0	3/8"-16	3"	1-1/2"	3/8"	3/4"	7/16"	12
18562 2	3/8"-16	3-3/4"	2"	3/8"	3/4"	7/16"	14
11528 2	3/8"-16	4"	1-1/2"	3/8"	3/4"	7/16"	16
18564 6	3/8"-16	5"	2-1/2"	3/8"	3/4"	7/16"	18
18570 7	1/2"-13	3-3/4"	1-1/2"	3/8"	1"	9/16"	29
18571 4	1/2"-13	4"	1-1/2"	3/8"	1"	9/16"	30
18580 6	1/2"-13	4"	1-1/2"	1/2"	1"	9/16"	30
18572 1	1/2"-13	5"	1-1/2"	3/8"	1"	9/16"	36
18575 2	1/2"-13	5"	2"	3/8"	1"	9/16"	36
18573 8	1/2"-13	6"	1-1/2"	3/8"	1"	9/16"	42
18590 5	5/8"-11	4-1/2"	2"	5/8"	1-1/4"	11/16"	50
18574 5	5/8"-11	5"	1-3/4"	5/8"	1-1/4"	11/16"	55
18576 9	5/8"-11	6"	1-3/4"	5/8"	1-1/4"	11/16"	63
18577 6	5/8"-11	6"	2-1/2"	5/8"	1-1/4"	11/16"	63
18608 7	3/4"-10	4-1/2"	2"	3/4"	1-1/2"	13/16"	77
18578 3	3/4"-10	5"	1-3/4"	5/8"	1-1/2"	13/16"	83
18579 0	3/4"-10	6"	1-3/4"	5/8"	1-1/2"	13/16"	95
18612 4	3/4"-10	6"	2-1/2"	3/4"	1-1/2"	13/16"	95
18620 9	7/8"-9	6"	2"	3/4"	1-3/4"	15/16"	146
18625 4	7/8"-9	6"	2"	7/8"	1-3/4"	15/16"	146

* Measured from center of boss

DROP FORGED BLANK ROD ENDS TYPE 316 STAINLESS STEEL

Stock No.	Part No.	Diameter Inches	*Length Inches	Weight Per 100
C-134SS	18540 0	1/4"	3"	6.1
C-134SS-A	18555 4	1/4"	6"	11
C-135SS	18557 8	5/16"	3"	9.5
C-135SS-A	18560 6	5/16"	6"	18
C-217SS	18535 6	3/8"	3"	14
C-136SS	18563 9	3/8"	6"	25.5
C-138SS	18565 3	1/2"	6"	47
C-139SS	18585 1	5/8"	6"	77.5
C-140SS	18605 6	3/4"	6"	112
C-141SS	18615 5	7/8"	6"	164

* Measured from center of boss

See page 28 for additional dimensional information.



STAINLESS STEEL SECTION



Regular



Shoulder

DROP FORGED EYE BOLTS TYPE 316 STAINLESS STEEL



Diameter & Shank Length	Regular		Shoulder	
	Part No.	Weight Per 100	Part No.	Weight Per 100
1/4" x 2"	08205 1	6.4	08605 9	7.4
1/4" x 3"	08208 2	8	N.A.	N.A.
1/4" x 4"	08211 2	9.3	08611 0	10.7
1/4" x 5"	08214 3	10.4	N.A.	N.A.
1/4" x 6"	08217 4	11.8	N.A.	N.A.
5/16" x 2-1/4"	08222 8	12.7	08622 6	12.9
5/16" x 3-1/4"	08225 9	15	N.A.	N.A.
5/16" x 4-1/4"	08228 0	16.5	08628 8	16.8
3/8" x 2-1/2"	08239 6	19.2	08639 4	21
3/8" x 4-1/4"	08245 7	24.4	08645 5	29
1/2" x 3-1/4"	08262 4	46	08662 2	46
1/2" x 6"	08268 6	60	08668 4	63
5/8" x 4-1/2"	08282 2	79	08682 0	99

NOTE:
Hex Nuts
are imported

See pages 14-15 for additional dimensional information.



THIMBLES TYPE 304 STAINLESS STEEL

Rope Diameter	Part No.	Weight Per 100
1/8"	22305 8	2.1
3/16"	22310 2	2.1
1/4"	22315 7	3.4
5/16"	22320 1	4.6
3/8"	22325 6	9
1/2"	22335 5	17

See page 13 for additional dimensional information.

STAINLESS STEEL SECTION

304 STAINLESS STEEL 36" - 72" - 144" LENGTHS

Thread Diameter	36" Length Part No.	72" Length Part No.	144" Length Part No.	Est. Wt Per 100 Ft. (lbs)
6 - 32	37011 0	37014 1	37020 2	3.6
8 - 32	37031 8	37034 9	37040 0	5.3
12 - 24	37071 4	37074 5	37080 6	9.2
1/4" - 20	37091 2	37094 3	37100 1	12.1
5/16" - 18	37111 7	37114 8	37120 9	19.6
3/8" - 16	37131 5	37134 6	37140 7	28.7
7/16" - 14	37151 3	37154 4	37160 5	39.8
1/2" - 13	37171 1	37174 2	37180 3	52.6
9/16" - 12	37191 9	37194 0	37200 8	66.7
5/8" - 11	37211 4	37214 5	37220 6	83.3
3/4" - 10	37231 2	37234 3	37240 4	123
7/8" - 9	37251 0	37254 1	37260 2	170
1" - 8	37271 8	37274 9	37280 0	223



WIRE ROPE CLIPS TYPE 304 STAINLESS STEEL

Stock No.	Rope Size	Part No.	Weight Per 100
2	1/16" - 3/32"	23605 8	5
4	1/8" - 5/32"	23610 2	7
6	3/16" - 7/32"	23615 7	11
8	1/4" - 5/16"	23620 1	18
10	3/8"	23630 0	38
12	7/16" - 1/2"	23635 5	55



STAINLESS STEEL SECTION

MACHINERY EYE BOLTS – THREADED TYPE 316 STAINLESS STEEL



Shoulder

SHOULDER PATTERN

Shoulder Pattern No.	Bolt Dia.	Shank Length	Part No.	Weight Per 100
21SS	1/4"	1"	13105 6	6
22SS	5/16"	1-1/8"	13125 4	10
23SS	3/8"	1-1/4"	13145 2	16
25SS	1/2"	1-1/2"	13185 8	38
27SS	5/8"	1-3/4"	13225 1	73.5
28SS	3/4"	2"	13248 0	99.5

See pg. 18 for additional dimensional information.



SPECIAL LENGTH SHOULDER PATTERN

Bolt Dia.	Shank Length	Part No.	Weight Per 100
1/4"	3"	13110 0	10
5/16"	3"	13130 8	14
3/8"	3"	13150 6	22
1/2"	3"	13190 2	44
5/8"	3"	13230 5	82



Plain

PLAIN PATTERN

Plain Pattern No.	Bolt Dia.	Shank Length	Part No.	Weight Per 100
1SS	1/4"	1"	14205 2	5
2SS	5/16"	1-1/8"	14210 6	10.5
3SS	3/8"	1-1/4"	14215 1	15.5
5SS	1/2"	1-1/2"	14220 5	33
7SS	5/8"	1-3/4"	14225 0	64
8SS	3/4"	2"	14230 4	90.5



SPECIAL LENGTH PLAIN PATTERN

Bolt Dia.	Shank Length	Part No.	Weight Per 100
1/4"	3"	14240 3	10
5/16"	3"	14250 2	14
3/8"	3"	14260 1	18
1/2"	3"	14270 0	38
5/8"	3"	14280 9	70



REGULAR DROP FORGED EYE NUTS TYPE 316 STAINLESS STEEL

Bail Size	Tap Size	Drilled & Tapped	
		Part No.	Weight Per 100
1/4"	1/4" - 20	16505 1	8.2
1/4"	5/16" - 18	16510 5	8
3/8"	3/8" - 16	16520 4	34
3/8"	1/2" - 13	16525 9	29.3
1/2"	5/8" - 11	16530 3	61.5
5/8"	3/4" - 10	16535 8	103

See page 26 for additional dimensional information.

HEAVY DUTY DROP FORGED EYE NUTS TYPE 316 STAINLESS STEEL



Stock No.	Tap Size	Part No.	Weight Per 100
100SS	3/8" - 16	17505 0	15
101SS	1/2" - 13	17510 4	37.5
102SS	5/8" - 11	17515 9	82.5
103SS	3/4" - 10	17520 3	145

STAINLESS STEEL SECTION



TURNED EYE BOLTS – MACHINE THREAD TYPE 304 STAINLESS STEEL



Stock No.	Thread Diameter	Part No.	Shank Length	Weight Per 100
A-1SS	1/8" (6-32)	07255 7	3/4"	.75
B-1SS	5/32" (8-32)	07260 1	1-1/8"	1.31
C-1SS	3/16" (10-24)	07265 6	1"	1.81
C-2SS	3/16" (10-24)	07270 0	1-3/8"	1.875
C-3SS	3/16" (10-24)	07275 5	2"	2.375
C-4SS	3/16" (10-24)	07280 9	3"	2.94
E-1SS	1/4"-20	07290 8	1"	3.75
E-2SS	1/4"-20	07295 3	1-1/2"	4.375
E-2SS-A	1/4"-20	07297 7	1-7/8"	5.2
E-3SS	1/4"-20	07305 9	2"	5
E-4SS	1/4"-20	07310 3	2-1/2"	5.6
E-5SS	1/4"-20	07315 8	3"	6.3
E-6SS	1/4"-20	07320 2	3-1/2"	6.9
E-7SS	1/4"-20	07325 7	4"	7.5
E-8SS	1/4"-20	07330 1	5"	8
E-9SS	1/4"-20	07335 6	6"	9
F-1SS	5/16"-18	07340 0	1"	7
F-2SS	5/16"-18	07345 5	2"	9
F-2SS-A	5/16"-18	07347 9	2-1/4"	9.7
F-3SS	5/16"-18	07355 4	2-1/2"	10

Stock No.	Thread Diameter	Part No.	Shank Length	Weight Per 100
F-4SS	5/16"-18	07360 8	3"	11
F-5SS	5/16"-18	07365 3	3-1/2"	11
F-6SS	5/16"-18	07370 7	4"	12
F-7SS	5/16"-18	07375 2	5"	14
F-8SS	5/16"-18	07380 6	6"	15
F-9SS	5/16"-18	07385 1	6-1/2"	18
G-1SS	3/8"-16	07390 5	1"	12
G-2SS	3/8"-16	07395 0	2"	15
G-2SS-A	3/8"-16	07397 4	2-1/2"	15.7
G-3SS	3/8"-16	07405 6	2-1/2"	15.5
G-4SS	3/8"-16	07410 0	3"	17
G-5SS	3/8"-16	07415 5	3-1/2"	18
G-6SS	3/8"-16	07420 9	4"	21
G-7SS	3/8"-16	07425 4	5"	22
G-8SS	3/8"-16	07430 8	6"	24
G-9SS	3/8"-16	07435 3	8"	30
J-1SS	1/2"-13	07460 5	2"	33
J-2SS	1/2"-13	07465 0	4"	41
J-3SS	1/2"-13	07470 4	6"	50
J-4SS	1/2"-13	07475 9	8"	58

See page 35 for additional dimensional information.

NOTE:
Hex Nuts
are imported

S-HOOKS – TYPE 304 STAINLESS STEEL

Stock No.	Part No.	Dimensions – Inches				Weight Per 100 (lbs)	Working Load Limit (lbs)
		Wire Diameter	Overall Length	Hooks Inside Dia.	Opening Hooks		
S-1SS	06211 4	.080"	3/4"	1/4"	1/8"	.26	7
S-1SS-A	06213 8	.105"	1"	5/16"	5/32"	.55	16
S-2SS	06214 5	.114"	1-1/4"	3/8"	3/16"	.83	17
S-2SS-A	06215 2	.148"	1-1/2"	7/16"	7/32"	1.62	26
S-3SS	06217 6	.186"	1-3/4"	1/2"	1/4"	1.62	40
S-4SS	06220 8	.220"	2-1/8"	5/8"	5/16"	5.15	58
S-5SS	06223 7	.250"	2-1/2"	3/4"	7/16"	7.5	70
S-6SS	06226 8	.312"	3"	7/8"	1/2"	13.9	132
S-7SS	06229 9	.375"	3-1/2"	1"	1/2"	23.44	170



See page 31 for additional dimensional information.



STAINLESS STEEL SECTION



ROUND BEND U-BOLTS – TYPE 304 STAINLESS STEEL

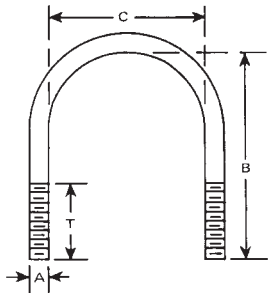

NOTE:
Hex Nuts
are imported

Dimensions U-Bolts Only (A x C x B)	Pipe Size	Stainless Steel U-Bolts & 2 Nuts			Stainless Steel U-Bolts Plates & 2 Nuts		
		Stock No.	Part No.	Weight Per 100	Stock No.	Part No.	Weight Per 100
1/4" x 9/16" x 1-1/4"	1/4"	01SS	50405 8	5	1SS	50605 2	7
1/4" x 3/4" x 1-1/4"	3/8"	02SS	50408 9	5	2SS	50608 3	7
1/4" x 3/4" x 2-1/4"	3/8"	03SS	50411 9	7	3SS	50611 3	9
1/4" x 1" x 1-3/4"	1/2"	04SS	50414 0	7	4SS	50614 4	9
1/4" x 1-1/8" x 2"	3/4"	05SS	50420 1	7	5SS	50620 5	9
1/4" x 1-1/4" x 2-1/4"	3/4"	06SS	50426 3	7.5	6SS	50626 7	10
1/4" x 1-1/2" x 2-3/4"	1"	07SS	50429 4	9	7SS	50629 8	12
1/4" x 1-3/4" x 3"	1-1/4"	08SS	50432 4	9	8SS	50632 8	12
1/4" x 2" x 3-1/4"	1-1/2"	09SS	50435 5	9.5	9SS	50635 9	14
5/16" x 1" x 2-3/16"	1/2"	010SS	50438 6	11	10SS	50638 0	14
5/16" x 1-3/8" x 2-3/16"	1"	011SS	50444 7	12	11SS	50644 1	15
5/16" x 1-1/2" x 2-3/16"	1"	012SS	50450 8	12	12SS	50650 2	15
5/16" x 1-3/4" x 2-11/16"	1-1/4"	013SS	50453 9	13	13SS	50653 3	17.5
5/16" x 2" x 2-11/16"	1-1/2"	014SS	50459 1	14	14SS	50659 5	19
5/16" x 2-1/2" x 3-3/16"	2"	015SS	50465 2	16	15SS	50665 6	21
5/16" x 3" x 3-11/16"	2-1/2"	016SS	50471 3	18	16SS	50671 7	24
3/8" x 1" x 2-1/4"	1/2"	017SS	50474 4	17.5	17SS	50674 8	22.5
3/8" x 1-1/4" x 2-1/4"	3/4"	018SS	50477 5	18	18SS	50677 9	24
3/8" x 1-1/2" x 2-1/2"	1"	019SS	50480 5	18.5	19SS	50680 9	26
3/8" x 1-3/4" x 2-3/4"	1-1/4"	020SS	50483 6	20	20SS	50683 0	27.5
3/8" x 2" x 2-5/8"	1-1/2"	021SS	50486 7	20	21SS	50686 1	29
3/8" x 2-1/2" x 3-1/8"	2"	022SS	50489 8	24.5	22SS	50689 2	33
3/8" x 3" x 3-5/8"	2-1/2"	023SS	50492 8	26	23SS	50692 2	38
3/8" x 3-1/2" x 4-1/8"	3"	024SS	50495 9	30	24SS	50698 4	42.5
1/2" x 3" x 4-1/2"	2-1/2"	025SS	50497 3	59	25SS	50701 1	71
1/2" x 3-1/2" x 5"	3"	026SS	50500 0	64	26SS	50704 2	78
1/2" x 4" x 5-1/2"	3-1/2"	027SS	50503 1	70	27SS	50710 3	87
1/2" x 4-1/2" x 6"	4"	028SS	50506 2	75	28SS	50713 4	92.5
1/2" x 5-5/8" x 7-1/4"	5"	029SS	50509 3	90	N.A.	N.A.	N.A.
1/2" x 6-3/4" x 8-3/8"	6"	030SS	50512 3	101	N.A.	N.A.	N.A.
1/2" x 8-3/4" x 10-3/8"	8"	031SS	50515 4	120	N.A.	N.A.	N.A.
*3/4" x 10-7/8" x 13-13/16"	10"	032SS	50560 4	440	N.A.	N.A.	N.A.
*7/8" x 12-7/8" x 16-1/16"	12"	033SS	50570 3	710	N.A.	N.A.	N.A.
*7/8" x 14-1/8" x 17-5/16"	14"	034SS	50574 1	755	N.A.	N.A.	N.A.
*7/8" x 16-1/8" x 19-5/16"	16"	035SS	50578 9	850	N.A.	N.A.	N.A.

*Full Stock Diameter with Cut Thread

See pages 32-34 for additional
dimensional information.

STAINLESS STEEL SECTION



ROUND BEND LONG TANGENT U-BOLTS WITH 4 NUTS TYPE 304 STAINLESS STEEL

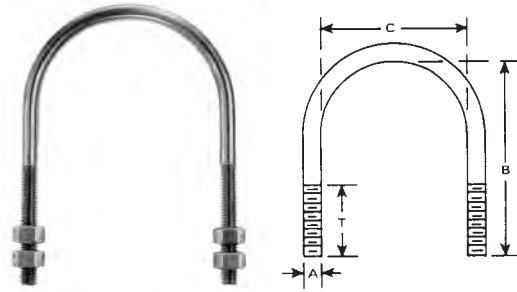

Stock No.	Part No.	Pipe Size	Diameter (A)	Inside Width (C)	Inside Length (B)	Thread Length (T)	Weight Per 100
LT-BSS	51660 0	1/2"	1/4" - 20	7/8"	2-15/16"	2-1/2"	9
LT-CSS	51665 5	3/4"	1/4" - 20	1-1/8"	3-3/16"	2-1/2"	10
LT-DSS	51670 9	1"	1/4" - 20	1-3/8"	3-7/16"	2-1/2"	11
LT-1SS	51705 8	1/2"	3/8" - 16	15/16"	3"	2-3/8"	24
LT-2SS	51710 2	3/4"	3/8" - 16	1-1/8"	3-5/16"	2-3/8"	25.5
LT-3SS	51715 7	1"	3/8" - 16	1-3/8"	3-7/16"	2-3/8"	26.5
LT-4SS	51720 1	1-1/4"	3/8" - 16	1-11/16"	3-23/32"	2-3/8"	28
LT-5SS	51725 6	1-1/2"	3/8" - 16	2"	4"	2-1/2"	30
LT-6SS	51730 0	2"	3/8" - 16	2-7/16"	4-7/16"	2-1/2"	33
LT-7SS	51735 5	2-1/2"	1/2" - 13	2-15/16"	5-7/32"	3"	71
LT-8SS	51740 9	3"	1/2" - 13	3-9/16"	5-3/4"	3"	77
LT-9SS	51745 4	3-1/2"	1/2" - 13	4-1/16"	6-1/4"	3"	82
LT-10SS	51750 8	4"	1/2" - 13	4-9/16"	6-3/4"	3"	89
LT-11SS	51755 3	5"	1/2" - 13	5-5/8"	7-13/16"	3"	101
LT-12SS	51760 7	6"	5/8" - 11	6-3/4"	9-1/2"	3-3/4"	194.5
LT-13SS	51765 2	8"	5/8" - 11	8-3/4"	11-1/8"	3-3/4"	223.5
LT-14SS	51770 6	10"	3/4" - 10	10 -7/8"	13-13/16"	4"	460

NOTE:
Hex Nuts
are imported

See page 34 for additional dimensional information.



SQUARE BEND U-BOLTS WITH 2 NUTS AND 2 WASHERS TYPE 304 STAINLESS STEEL

Stock No.	Part No.	Diameter (A)	Inside Width (C)	Overall Length (B)	Thread Length (T)	Weight Per 100
SB-1SS	51105 6	3/8" - 16	2"	3"	1-1/2"	25.5
SB-2SS	51110 0	3/8" - 16	2"	5"	3"	35.5
SB-3SS	51115 5	3/8" - 16	2"	7"	3-3/4"	44.5
SB-4SS	51120 9	3/8" - 16	4"	3"	1-1/2"	29.5
SB-5SS	51125 4	3/8" - 16	4"	5"	3"	40
SB-6SS	51130 8	3/8" - 16	4"	7"	3-3/4"	49.5
SB-7SS	51135 3	3/8" - 16	6"	5"	3"	44.5
SB-8SS	51140 7	3/8" - 16	6"	7"	3-3/4"	56
SB-9SS	51145 2	3/8" - 16	6"	9"	5-5/8"	63

NOTE:
Hex Nuts
and Washers
are imported

See page 34 for additional dimensional information.



FORMED OR FORGED FITTINGS

The schematic drawings in adjoining columns represent basic rod or wire forms and steel eye bolt forgings. Space does not permit the design illustrations of all parts that we are capable of manufacturing.

A review of complete catalog literature will indicate an extensive listing of standard stock sizes of round bend U-bolts, turned or formed eye bolts and forged steel eye bolts in several patterns.

When it is not feasible to utilize a standard product, we are prepared and equipped to manufacture requirements to specification. Inquiries are solicited.

Variation in quantity: on special items we reserve the right to a maximum 10% variation for allowances in manufacture.

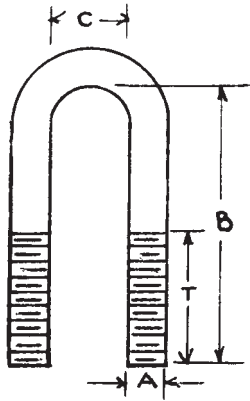

Figure No. 1

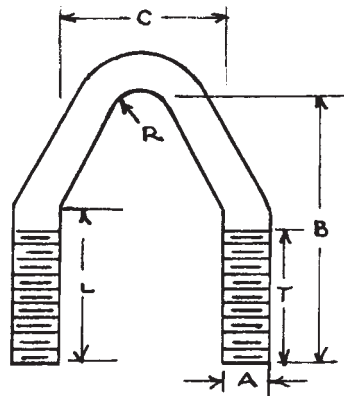

Figure No. 2

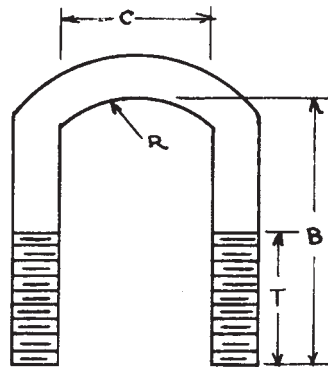

Figure No. 3

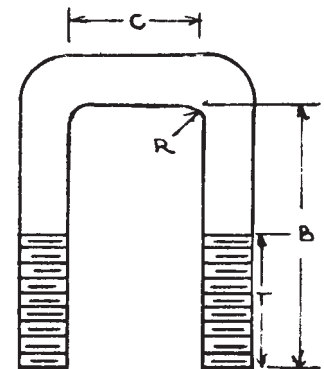

Figure No. 4

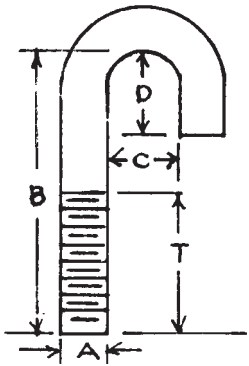

Figure No. 5

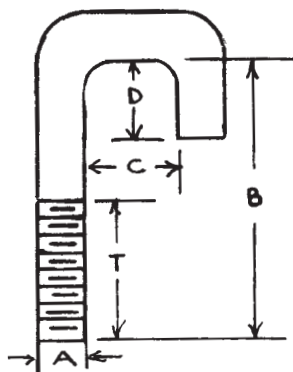

Figure No. 6

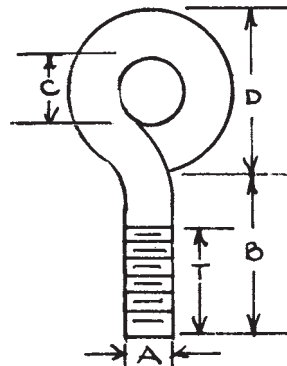

Figure No. 7

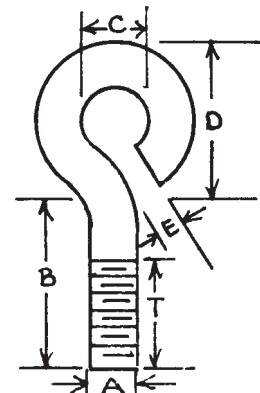

Figure No. 8

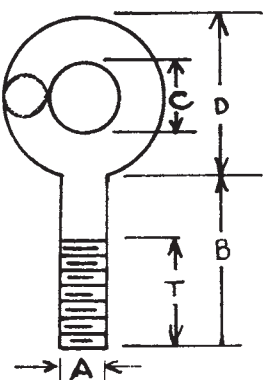

Figure No. 9

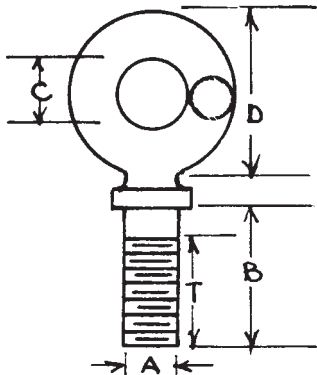

Figure No. 10

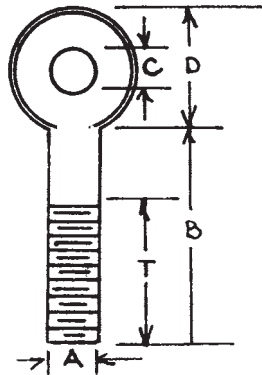
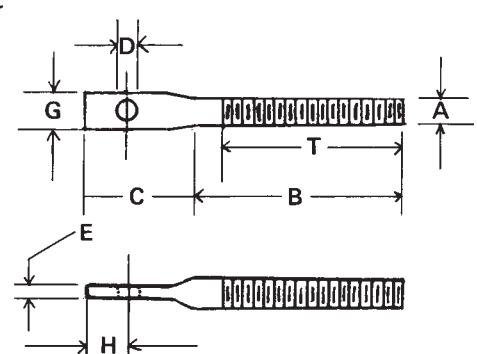

Figure No. 11



Spade Bolt

INDEX

Item	Page	Item	Page
- A -			
Alloy, (B7 4140) Threaded Rod	38	Ring Bolts, Drop Forged, Galvanized Regular & Shoulder Nut	16
Alloy Steel Hoist Rings	23	Ring Bolts, Drop Forged, Galvanized Regular & Shoulder Screw	17
Anchor Shackles, Round Pin, Screw Pin & Bolt Type	9	Rod, Threaded, Self Colored, Zinc Plated, Galvanized & Stainless Steel	37, 38, 41
Angles, Steel	39	Rod Ends, Drop Forged Blank, Black Oxide	28, 29
Angles, Slotted Steel	39	Rod Ends, Stainless Steel	40
- B -			
U-Bolts		Rod Ends, Turnbuckle	7
U-Bolts, Stainless Steel	44, 45	Rounds, Unthreaded Rod	38
U-Bolts, Hot Dip Galvanized	32, 33, 34	Round Pin, Anchor & Chain Shackles	9, 10
U-Bolt, Display	33	- S -	
Washers, Bevel	31	Snap Hook	24
- C -			
Chain Shackles	10	Swivel Hook	25
Chain Swivels	25	S-Hooks	31
Clips, Wire Rope, Forged & Malleable	11, 12	S-Hooks, Stainless Steel	43
Clips, Wire Rope, Stainless Steel	41	Shackles	
Clips, Grip, Chicago Grip	12	Round Pin, Anchor & Chain	9, 10
Clevis Grab Hooks	24	Bolt Type, Anchor & Chain	9, 10
Clevis Pins	31	Screw Pin, Anchor & Chain	9, 10
Clevis Pins, SAE	30	Slotted Angles, Zinc Plated Steel	39
Coupling Nuts	38	Slotted Flats, Zinc Plated Steel	39
- D -			
Displays		Square Keystock	39
Midget Aluminum Turnbuckles	8	Stainless Steel	
Turned Eye Bolts	36	Eye Bolts, Regular & Shoulder Nut	42
U-Bolts	33	Machinery Eye Bolts	42
- E -			
Eye Bolts		Rod Ends	40
Machinery, Metric	22	S-Hooks	43
Machinery, Plain & Shoulder Pattern	18, 19, 21	Threaded Rod	41
Machinery, Stainless Steel	42	Turned Eye Bolts	43
Machinery, Zinc Plated & Hot Galvanized	20	U-Bolts	44, 45
Regular & Shoulder Nut	14, 15	Wire Rope Clips	41
Regular & Shoulder Nut, Stainless Steel	41	Wire Rope Thimbles	41
Regular & Shoulder Screw	17	Stub End Turnbuckles	4
Regular & Shoulder Nut Rings Bolts	16	Swivels	
Regular & Shoulder Screw Ring Bolts	17	Eye & Eye, Jaw & Eye, Chain	25
Turned, Machine Thread, Lag & Welded	35, 36	- T -	
Turned, Stainless Steel	43	Thimbles, Wire Rope Regular & Heavy Duty	13
Eye Hoist Hooks	24	Thimbles, Wire Rope Stainless Steel	41
Eye Nuts	26, 27	Threaded Rod, Stainless Steel, B-7, Self-Colored, Zinc Plated & Hot Dip Galvanized	39, 40, 41, 42
Eye Nuts, Stainless Steel	42	Turnbuckles, Aluminum, Midget	8
Eye, Pad	28	Turnbuckles, Drop Forged	4, 5, 6, 7
Eye & Eye Swivels	25	Turnbuckles, Malleable, Midget	8
Eye & Eye Turnbuckles	5	Turned Eye Bolts, Machine & Lag Thread	35, 36
- F -			
Flats, Zinc Plated Steel	39	Turned Eye Bolts, Welded Eye	36
Flats, Zinc Plated Slotted Steel	39	Turned Eye Bolts, Stainless Steel	43
- H -			
Hoist Rings, Alloy Steel	23	- U -	
Hook Clevis Grab	24	U-Bolts, Zinc Plated Round Bend, Square Bend, Long Tangent	32, 33, 34
Hook & Eye Turnbuckles	6	U-Bolt Displays	33
Hook & Hook Turnbuckles	5	U-Bolts Hot Dip Galvanized	32, 34
Hooks, Hoist, Eye	24	U-Bolts Stainless Steel	44, 45
Hooks, S-	31	- W -	
Hook, Snap	24	Wire Rope Clips, Drop Forged & Malleable	11, 12
Hooks, Swivel	25	Wire Rope Clips, Stainless Steel	41
- J -			
Jaw & Eye Swivels	25	Wire Rope Thimbles, Regular & Heavy Duty	13
Jaw & Eye Turnbuckles	7	Wire Rope Thimbles, Stainless Steel	41
Jaw & Jaw Turnbuckles	7	- Y -	
- K -			
Keystock, Square	39	Yoke Ends, Adjustable & Plain	30
- L -			
Latch Kits for Hoist - Eye Hooks	24		
Lifting Eyes	23		
- M -			
Machinery Eye Bolts, Metric	22		
Machinery Eye Bolts, Plain Pattern & Shoulder	18, 19, 20, 21		
Machinery Eye Bolts, Stainless Steel	42		
- N -			
Nuts, Coupling	38		
Nuts, Eye	26, 27		
Nuts, Eye, Stainless Steel	42		
- P -			
Pins, Clevis	31		
Pins, Clevis SAE	30		
Pad Eyes	28		

Notes